

Metrics

INTRODUCTION

Most threaded fasteners are covered by specifications that define required mechanical properties, such as tensile strength, yield strength, proof load and hardness. These specifications are carefully considered in initial selection of fasteners for a given application. To assure continued satisfactory vehicle performance, replacement fasteners used should be of the correct strength, as well as the correct nominal diameter, thread pitch, length, and finish.

Most original equipment fasteners (English system or Metric) are identified with markings or numbers indicating the strength of the fastener. These markings are described in the pages that follow. Attention to these markings is important in assuring that the proper replacement fasteners are used.

Further, some metric fasteners, especially nuts, are colored blue. This metric blue identification is in most cases a temporary aid for production start-up, and color will generally revert to normal black or bright after start-up.

English system and metric system fasteners are available through your Ford Parts and Service operation.

NOMENCLATURE FOR BOLTS

(ENGLISH) INCH SYSTEM

Bolt, 1/2-13x1

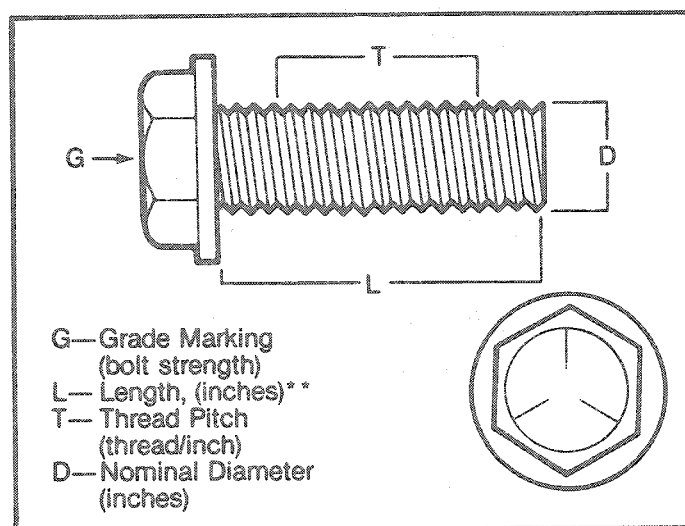

METRIC SYSTEM

Bolt M12-1.75x25

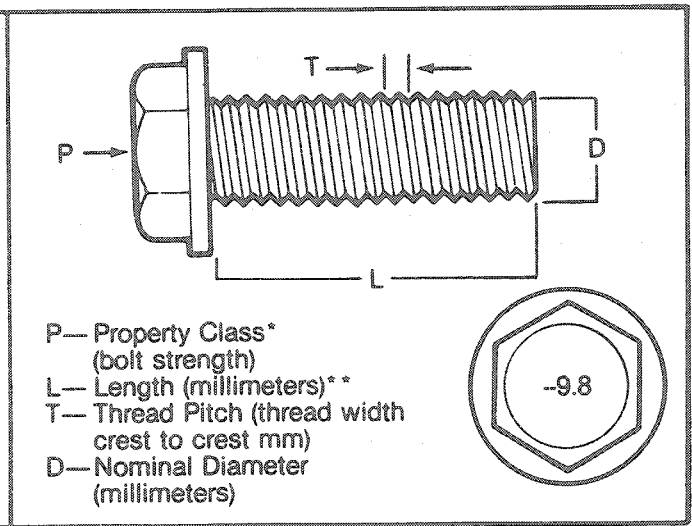

*The property class is an Arabic numeral distinguishable from the slash SAE English grade system.

**The length of all bolts is measured from the underside of the head to the end.

Metrics

BOLT STRENGTH IDENTIFICATION

(ENGLISH) INCH SYSTEM

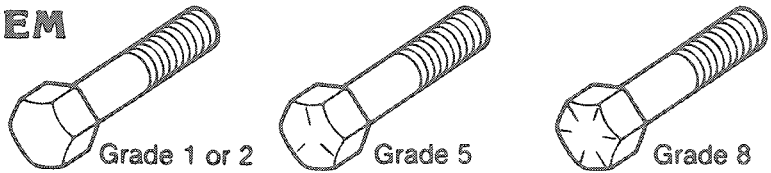

English (Inch) bolts—Identification marks correspond to bolt strength—increasing number of slashes represent increasing strength.

METRIC SYSTEM

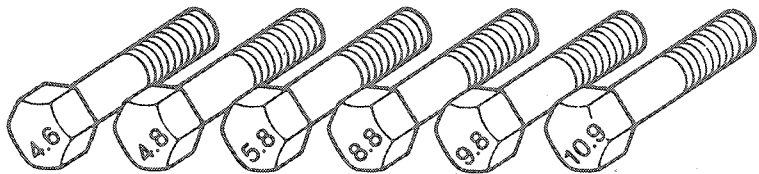



Metric bolts—Identification class numbers correspond to bolt strength—increasing numbers represent increasing strength. Common metric fastener bolt strength property are 9.8 and 10.9 with the class identification embossed on the bolt head.

HEX NUT STRENGTH IDENTIFICATION

(ENGLISH) INCH SYSTEM

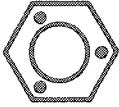
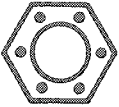
METRIC SYSTEM

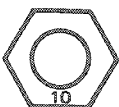
Grade	Hex Nut Grade 5	Hex Nut Grade 8	Class	Hex Nut Property Class 9	Hex Nut Property Class 10
Identification			Identification		
	3 Dots	6 Dots		Arabic 9	Arabic 10
Increasing dots represent increasing strength.			May also have blue finish or paint daub on hex flat. Increasing numbers represent increasing strength.		

OTHER TYPES OF PARTS

Metric identification schemes vary by type of part, most often a variation of that used of bolts and nuts. Note that many types of English and metric fasteners carry no special identification if they are otherwise unique.

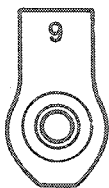

—Stamped U-Nuts

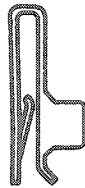

—Tapping, thread forming and certain other case hardened screws



CLASS 10.9



CLASS 9.8



CLASS 8.8

—Studs, Large studs may carry the property class number. Smaller studs use a geometric code on the end.

Metrics

ENGLISH METRIC CONVERSION

Description	Multiply	By	For Metric Equivalent
ACCELERATION	Foot/sec ²	0.304 8	metre/sec ² (m/s ²)
	Inch/sec ²	0.025 4	metre/sec ²
TORQUE	Pound-inch	0.112 98	newton-metres (N·m)
	Pound-foot	1.355 8	newton-metres
POWER	horsepower	0.746	kilowatts (kw)
PRESSURE or STRESS	inches of water	0.2491	kilopascals (kPa)
	pounds/sq. in.	6.895	kilopascals (kPa)
	pounds/sq. in.	0.069	bar
ENERGY or WORK	BTU	1 055.	joules (J)
	foot-pound	1.355 8	joules (J)
	kilowatt-hour	3 600 000. or 3.6×10^6	joules (J = one 'W's)
LIGHT	foot candle	10.764	lumens/metre ² (lm/m ²)
FUEL PERFORMANCE	miles/gal	0.425 1	kilometres/litre (km/l)
	gal/mile	2.352 7	litres/kilometre (l/km)
VELOCITY	miles/hour	1.609 3	kilometres/hr. (km/h)
LENGTH	inch	25.4	millimetres (mm)
	foot	0.304 8	metres (m)
	yard	0.914 4	metres (m)
	mile	1.609	kilometres (km)
AREA	inch ²	645.2	millimetres ² (mm ²)
		6.45	centimetres ² (cm ²)
	foot ²	0.092 9	metres ² (m ²)
	yard ²	0.836 1	metres ²
VOLUME	inch ³	16 387.	mm ³
		16.387	cm ³
		0.016 4	litres (l)
	quart	0.946 4	litres
	gallon	3.785 4	litres
	yard ³	0.764 6	metres ³ (m ³)
MASS	pound	0.453 6	kilograms (kg)
	ton	907.18	kilogram (kg)
	ton	0.90718	tonne (t)
FORCE	kilogram	9.807	newtons (N)
	ounce	0.278 0	newtons
	pound	4.448	newtons
TEMPERATURE	degree fahrenheit	(°F - 32) 0.556	degree Celsius (°C)

Metrics

DECIMAL AND METRIC EQUIVALENTS

Fractions	Decimal Inch	Metric mm
1/64	.015625	.397
1/32	.03125	.794
3/64	.046875	1.191
1/16	.0625	1.588
5/64	.078125	1.984
3/32	.09375	2.381
7/64	.109375	2.778
1/8	.125	3.175
9/64	.140625	3.572
5/32	.15625	3.969
11/64	.171875	4.366
3/16	.1875	4.763
13/64	.203125	5.159
7/32	.21875	5.556
15/64	.234375	5.953
1/4	.250	6.35
17/64	.265625	6.747
9/32	.28125	7.144
19/64	.296875	7.54
5/16	.3125	7.938
21/64	.328125	8.334
11/32	.34375	8.731
23/64	.359375	9.128
3/8	.375	9.525
25/64	.390625	9.922
13/32	.40625	10.319
27/64	.421875	10.716
7/16	.4375	11.113
29/64	.453125	11.509
15/32	.46875	11.906
31/64	.484375	12.303
1/2	.500	12.7

Fractions	Decimal Inch	Metric mm
33/64	.515625	13.097
17/32	.53125	13.494
35/64	.546875	13.891
9/16	.5625	14.288
37/64	.578125	14.684
19/32	.59375	15.081
39/64	.609375	15.478
5/8	.625	15.875
41/64	.640625	16.272
21/32	.65625	16.669
43/64	.671875	17.066
11/16	.6875	17.463
45/64	.703125	17.859
23/32	.71875	18.256
47/64	.734375	18.653
3/4	.750	19.05
49/64	.765625	19.447
25/32	.78125	19.844
51/64	.796875	20.241
13/16	.8125	20.638
53/64	.828125	21.034
27/32	.84375	21.431
55/64	.859375	21.828
7/8	.875	22.225
57/64	.890625	22.622
29/32	.90625	23.019
59/64	.921875	23.416
15/16	.9375	23.813
61/64	.953125	24.209
31/32	.96875	24.606
63/64	.984375	25.003
1	1.00	25.4

Metrics

TORQUE CONVERSION

NEWTON METRES (N·m)	POUND-FEET (LB·FT)
1	0.7376
2	1.5
3	2.2
4	3.0
5	3.7
6	4.4
7	5.2
8	5.9
9	6.6
10	7.4
15	11.1
20	14.8
25	18.4
30	22.1
35	25.8
40	29.5
50	36.9
60	44.3
70	51.6
80	59.0
90	66.4
100	73.8
110	81.1
120	88.5
130	95.9
140	103.3
150	110.6
160	118.0
170	125.4
180	132.8
190	140.1
200	147.5
225	166.0
250	184.4

POUND-FEET (LB·FT)	NEWTON METRES (N·m)
1	1.356
2	2.7
3	4.0
4	5.4
5	6.8
6	8.1
7	9.5
8	10.8
9	12.2
10	13.6
15	20.3
20	27.1
25	33.9
30	40.7
35	47.5
40	54.2
45	61.0
50	67.8
55	74.6
60	81.4
65	88.1
70	94.9
75	101.7
80	108.5
90	122.0
100	135.6
110	149.1
120	162.7
130	176.3
140	189.8
150	203.4
160	216.9
170	230.5
180	244.0