

DESCRIPTION AND OPERATION (Continued)

When the headlamp switch is on and the LH front door is opened, power is supplied through Circuits 159 and 257 to the warning chime.

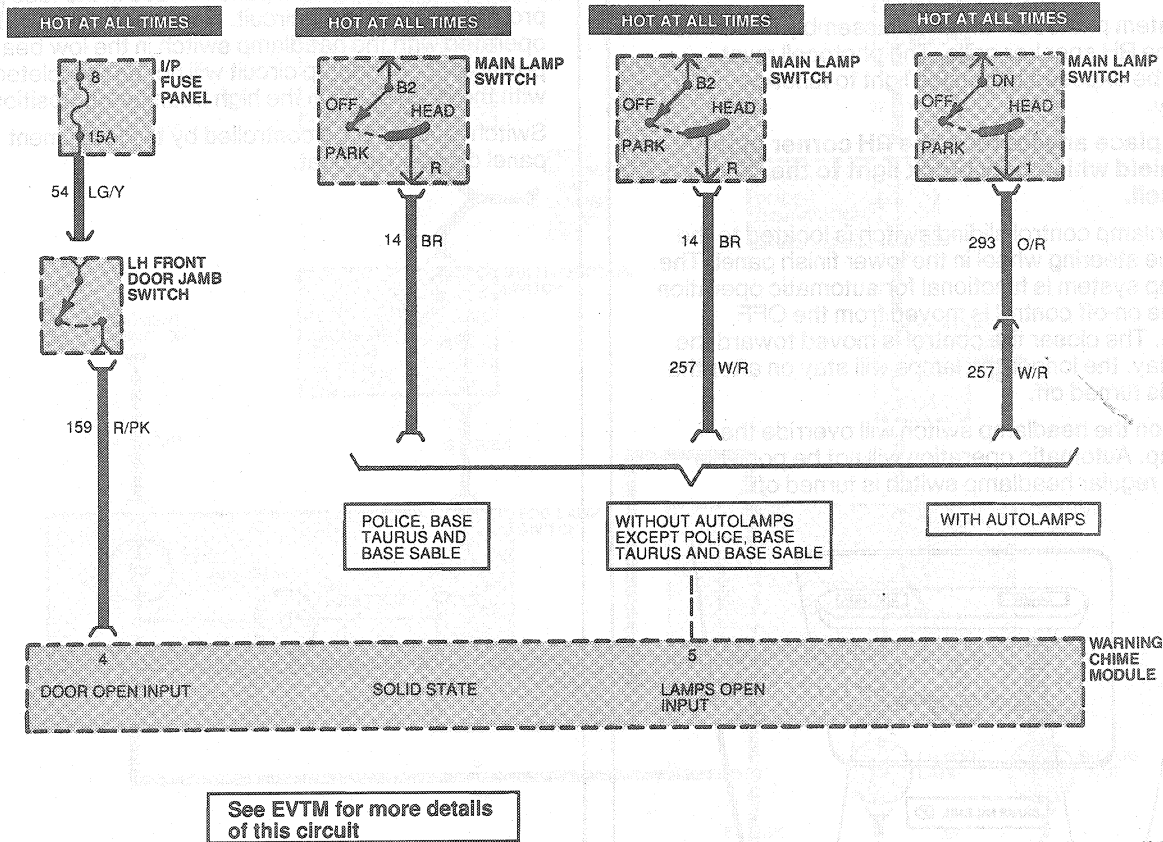

K17184-A

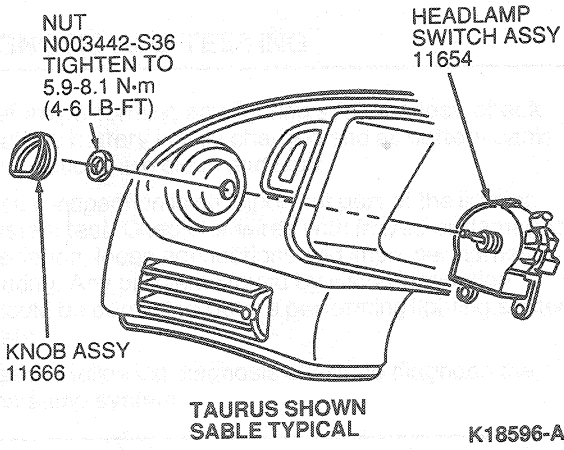

Headlamp Delay System—Autolamp

The autolamp system provides light sensitive automatic on-off control of the exterior lamps normally controlled by the regular headlamp switch. This system also provides increased visibility for occupants leaving the vehicle. The autolamp system keeps the lamps on for a preselected period of time after the ignition is turned off. The preselected time lapse can be adjusted by the operator up to approximately 3 minutes.

The system consists of a light sensitive photocell / amplifier assembly, one dual-coil relay, and a time-delay control which includes an ON / OFF switch. Connections to the vehicle lamps parallel the regular headlamp switch connections, requiring the headlamp switch be turned to the OFF position for the automatic control feature.