

SECTION 15-01 Radio and Tape Chassis

SUBJECT	PAGE	SUBJECT	PAGE
CLEANING		REMOVAL AND INSTALLATION (Cont'd.)	
Cassette Tape Player.....	15-01-13	Premium Sound Amplifier (Low and High-Level).....	15-01-8
DESCRIPTION AND OPERATION		Radio and Digital Disc Player.....	15-01-7
Cassette Tape Player.....	15-01-5	Radio Interference Suppression.....	15-01-10
Control Functions.....	15-01-1	Station Wagon.....	15-01-9
Tape Error Messages.....	15-01-5	SPECIAL SERVICE TOOLS	15-01-13
DIAGNOSIS AND TESTING	15-01-7	SPECIFICATIONS	15-01-13
REMOVAL AND INSTALLATION		VEHICLE APPLICATION	15-01-1
JBL Amplifier.....	15-01-8		
JBL Suppression Choke.....	15-01-12		

VEHICLE APPLICATION

Taurus/Sable.

DESCRIPTION AND OPERATION

The premium low level sound system is available on Sable vehicles only. It consists of two premium front door speakers and two premium rear speakers. Separate signal return wiring to each speaker is used. The amplifier is in operation and is part of the circuit at all times.

Control Functions

Electronic Stereo Radio (ESR)

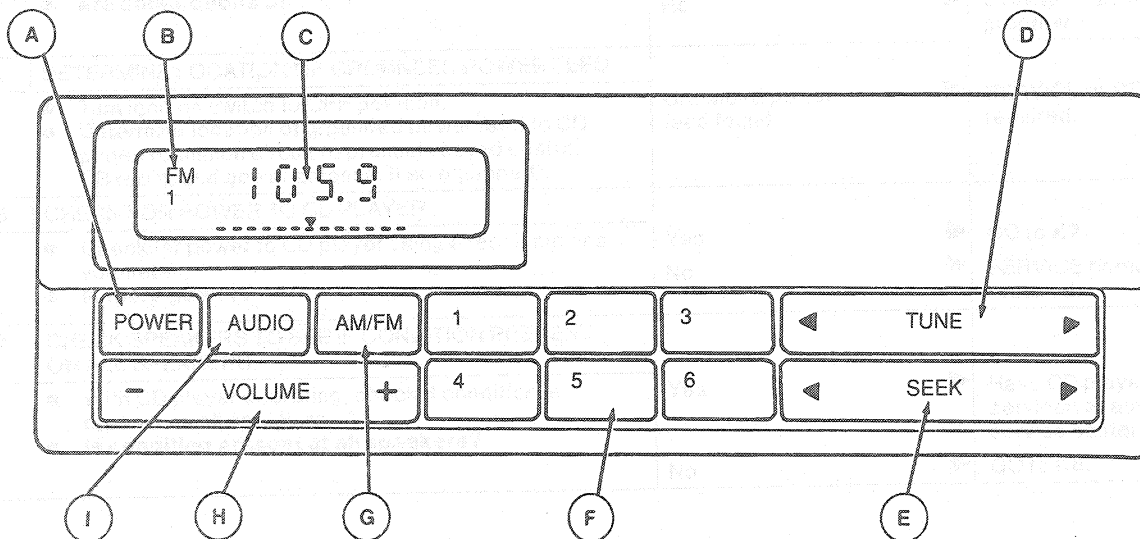

K16902-A

The following is a description of the various controls:

DESCRIPTION AND OPERATION (Continued)

- A. **POWER:** Push to turn ON, push again to turn OFF.
- B. **BAND INDICATOR:** Indicates if band is in AM, FM1 or FM2 setting.
- C. **STATION INDICATOR:** Indicates radio station frequency in radio mode.
- D. **TUNE:** This button is used to change the frequency up or down one increment at a time by pressing the right (>) or left (<) side of button. To change frequencies quickly, press and hold either right or left side of button.
- E. **SEEK:** Push right (>) side of SEEK button to tune radio to the next higher frequency station. Push left (<) side of SEEK button to tune radio down to next lower frequency station.
- F. **MEMORY BUTTONS:** The six memory buttons are used to store preferred broadcast stations in radio memory. To store a station, tune to desired station, push memory button in and hold for approximately two seconds until station sound returns, then release button. Repeat process for each memory button. Once a station is stored in memory, pushing a memory button for less than two seconds will cause radio to turn to stored station. All six memory buttons will store a station on AM, FM1 or FM2 for a total of 18 storable radio stations.
- G. **AM/FM:** Each successive push, when in radio mode, will select AM, FM1 or FM2 as indicated by band indicator in display window.
- H. **VOLUME:** Push right (+) side of VOLUME button to increase volume. Push left (-) side to decrease volume. If VOLUME button is held to the right or left, the volume will continuously increase or decrease (bars in display will show relative volume) until button is released.
- NOTE: If the VOLUME button is set above a preset listening level when ignition switch is turned off, when ignition switch is turned back on, the volume will return to a nominal listening level. However, if radio power is turned off with the POWER button before ignition is turned off, volume will return to the position it was set at previously, when radio power is switched back on.
- I. **AUDIO:** The AUDIO button is used to adjust bass, treble, speaker balance and fade. Illuminated bars in display will show relative positions.
- **Bass:** Push AUDIO button repeatedly until BASS is displayed. Push the right (+) side of VOLUME button to increase low frequency sound or left (-) side to decrease low frequency sounds.
 - **Treble:** Push AUDIO button repeatedly until TREB is displayed. Push the right (+) side of VOLUME button to increase high frequency sound or left (-) side to decrease high frequency sounds.
 - **Speaker Balance:** Push AUDIO button repeatedly until BAL is displayed. Push the right (+) side of VOLUME button to shift sound to right speakers or left (-) side to shift sound to left speakers.
 - **Speaker Fade:** Push AUDIO button repeatedly until FADE is displayed. Push the right (+) side of VOLUME button to shift sound to rear speakers or left (-) side to shift sound to front speakers.

Electronic Stereo Cassette (ESC)

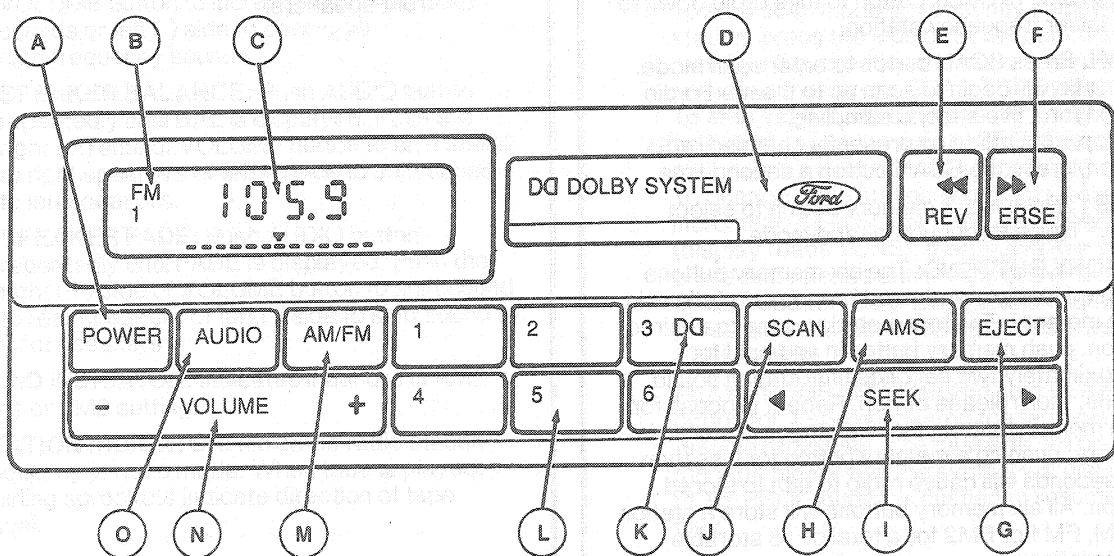

K16903-A

DESCRIPTION AND OPERATION (Continued)

The following explains various features of controls:

- A. **POWER:** Push to turn ON, push again to turn OFF.
- B. **BAND INDICATOR:** Indicates if band is in AM, FM1 or FM2 setting.
- C. **STATION INDICATOR:** Indicates radio station frequency in radio mode. When a tape is played, arrows indicate direction of tape removal.
- D. **TAPE OPENING:** When tape is inserted (with open edge to the right) and radio power is ON, tape begins to play.
- E. **REVERSE:** Push the left (<) side of REVERSE button to rewind a tape playing forward. To return tape play, push right (>) side of REVERSE button momentarily. Pushing both sides of REVERSE button simultaneously will reverse tape to opposite side (track).
- F. **REVERSE:** Push the right (>) side of REVERSE button to fast forward a tape playing forward. To return tape play, push left (<) side of REVERSE button momentarily. Pushing both sides of REVERSE button simultaneously will reverse tape to opposite side (track).
- G. **EJECT:** Press the EJECT button to stop the tape and eject cassette. The radio will resume playing if power is on.
- H. **AMS:** The automatic music search (AMS) button is used to change frequency up or down one increment at a time in radio mode. After pushing the AMS button, push and release either the right (>) or left (<) side of SEEK button. To change frequencies quickly, press and hold down either right or left side of SEEK button. In tape mode, use AMS button to change tape to next selection. First push and hold AMS button, then push either left or right side of REWIND button to find beginning of next tape selection.
- I. **SEEK:** Push right (>) side of SEEK button to tune radio to the next higher frequency station. Push left (<) side of SEEK button to tune radio down to next lower frequency station.
- J. **SCAN:** Press SCAN button to enter scan mode. The radio will begin to scan up to the next radio station for a five second sampling. To stop scan mode on presently sampled radio station, press the SCAN button a second time.
- K. **DOLBY:** Push No. 3 memory button to select Dolby® Noise Reduction in tape mode.
- L. **MEMORY BUTTONS:** The six memory buttons are used to store preferred broadcast stations in radio memory. To store a station, tune to desired station, push memory button in and hold for approximately two seconds until station sound returns, then release button. Repeat process for each memory button. Once a station is stored in memory, pushing a memory button for less than two seconds will cause radio to turn to stored station. All six memory buttons will store a station on AM, FM1 or FM2 for a total of 18 storable radio stations.

- M. **AM/FM:** Each successive push, when in radio mode, will select AM, FM1 or FM2 as indicated by band indicator in display window.
 - N. **VOLUME:** Push right (+) side of VOLUME button to increase volume, push left (-) side to decrease volume. If VOLUME button is held to the right or left, the volume will continuously increase or decrease (bars in display will show relative volume) until button is released.
- NOTE: If the VOLUME button is set above a preset listening level when ignition switch is turned off, when ignition switch is turned back on, the volume will return to a nominal listening level. However, if radio power is turned off with the POWER button before ignition is turned off, volume will return to the position it was set at previously, when radio power is switched back on.
- O. **AUDIO:** The AUDIO button is used to adjust bass, treble, speaker balance and fade. Illuminated bars in display will show relative positions.

- **Bass:** Push AUDIO button repeatedly until BASS is displayed. Push the right (+) side of VOLUME button to increase low frequency sound or left (-) side to decrease low frequency sounds.
- **Treble:** Push AUDIO button repeatedly until TREB is displayed. Push the right (+) side of VOLUME button to increase high frequency sound or left (-) side to decrease high frequency sounds.
- **Speaker Balance:** Push AUDIO button repeatedly until BAL is displayed. Push the right (+) side of VOLUME button to shift sound to right speakers or left (-) side to shift sound to left speakers.
- **Speaker Fade:** Push AUDIO button repeatedly until FADE is displayed. Push the right (+) side of VOLUME button to shift sound to rear speakers or left (-) side to shift sound to front speakers.

DESCRIPTION AND OPERATION (Continued)

DESCRIPTION AND OPERATION (Continued)

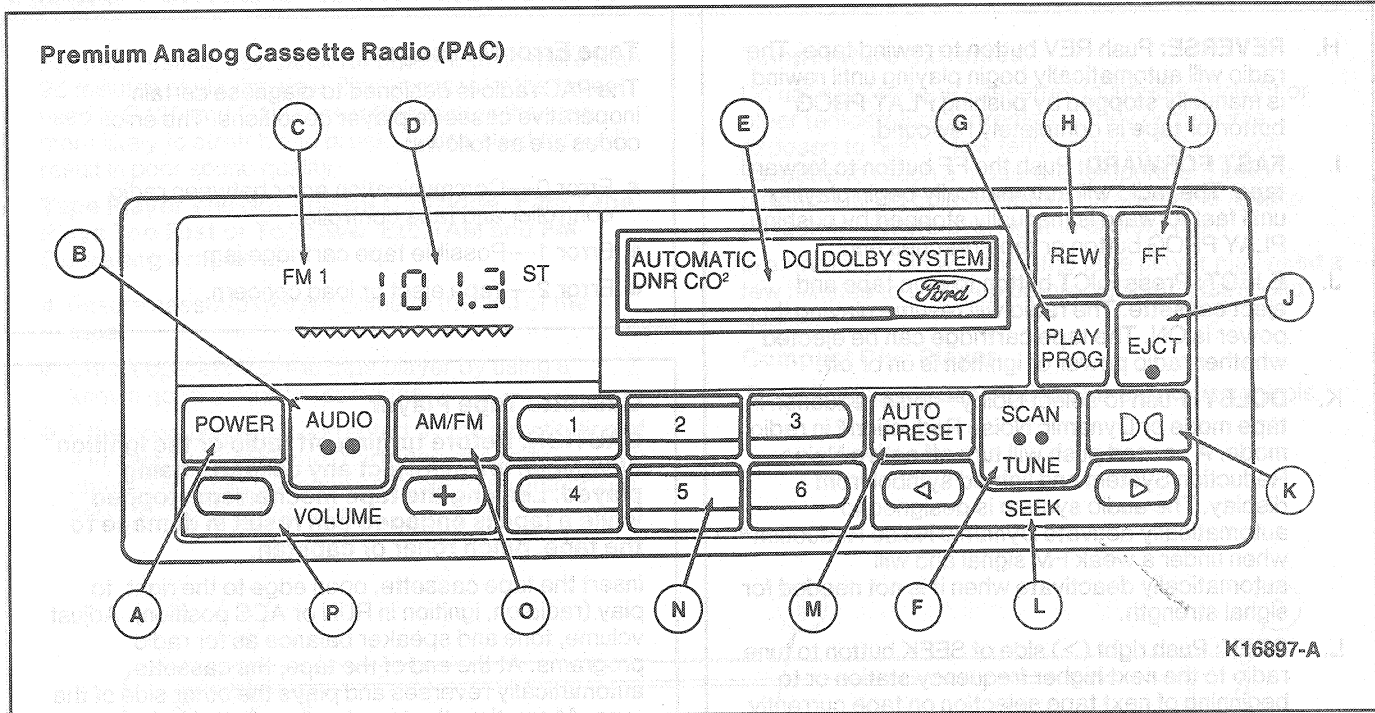

The features described are identical on all PAC radios.

- A. **POWER:** Push to turn radio ON, push again to turn OFF.
- B. **AUDIO:** The audio button is used to adjust bass, treble, speaker balance and fade. Illuminated bars in display will show relative positions.
- **BASS:** Push AUDIO button repeatedly until BASS is displayed. Push the right (+) side of VOLUME button to increase low frequency sounds or left (-) side to decrease low frequency sounds.
 - **TREBLE:** Push AUDIO button repeatedly until TREB is displayed. Push the right (+) side of VOLUME button to increase high-frequency sounds or left (-) side to decrease high-frequency sounds.
 - **SPEAKER BALANCE:** Push AUDIO button repeatedly until BAL is displayed. Push the right (+) side of VOLUME button to shift sound to right speakers or left (-) side to shift sound to left speakers.
 - **SPEAKER FADE:** Push AUDIO button repeatedly until FADE is displayed. Push the right (+) side of VOLUME button to shift sound to rear speakers or left (-) side to shift sound to front speakers.
- C. **BAND INDICATOR:** Indicates if band is in AM, FM1 or FM2 setting.
- D. **STATION INDICATOR:** Indicates radio station frequency in radio mode. When tape is played, whirling sprockets indicate direction of tape travel.

- E. **TAPE OPENING:** Cassette tape player is equipped with power loading. When tape is inserted (with open edge to the right) the loading mechanism draws the tape in the rest of the way and begins to play.
- F. **SCAN TUNE:** Press SCAN TUNE button to enter scan mode (display will blink SCN). Pushing the right (>) side of SEEK button will begin forward scan mode up to the next radio station for a five second sampling, or a five second sampling of the next tape selection on tape currently playing. Pushing left (<) side of SEEK button will begin reverse scan mode to previous radio station for a five second sampling or a five second sampling of previous tape selection on tape currently playing. To stop scan mode on presently sampled radio station, press the side of SEEK button which matches the direction the radio is currently scanning or re-press SCAN TUNE button. To stop scan mode on presently sampled tape selection, press the side of SEEK button which matches the direction tape is currently scanning. To change radio stations up or down by one increment, push SCAN TUNE button twice (display reads TUNE), then within five seconds press and release either right (>) or left (<) side of SEEK button. To change stations quickly, press and hold either the right or left side of SEEK button.
- G. **PLAY PROGRAM:** Push and hold PLAY PROG button for 1 second to stop the tape player and resume radio play. The cassette will be stored in the tape player and the symbol will display until PLAY PROG button is pushed to resume tape play.

DESCRIPTION AND OPERATION (Continued)

- H. **REVERSE:** Push REV button to rewind tape. The radio will automatically begin playing until rewind is manually stopped by pushing PLAY PROG button or tape is completely rewound.
- I. **FAST FORWARD:** Push the FF button to forward tape. The radio will automatically begin playing until fast forward is manually stopped by pushing PLAY PROG button or tape reaches end.
- J. **EJECT:** Press EJECT button to stop tape and eject cassette. The radio will resume playing if power is ON. The tape cartridge can be ejected whether radio power or ignition is on or off.
- K. **DOLBY:** Push to select Dolby® noise reduction in tape mode or Dynamic Noise Reduction® in radio mode. A second push will turn off active Noise Reduction System and lighted symbol from display. The audio system is designed to automatically activate Dynamic Noise Reduction® when under a weak FM signal and will automatically deactivate when it is not needed for signal strength.
- L. **SEEK:** Push right (>) side of SEEK button to tune radio to the next higher frequency station or to beginning of next tape selection on tape currently playing. Push left (<) side of SEEK button to tune radio down to next lower frequency station or to the beginning of tape selection currently playing.
- M. **AUTO PRESET:** Push the AUTO PRESET button for three seconds to use automatic memory store feature. The radio will automatically seek six strong stations and set them sequentially on memory buttons 1 through 6.
- N. **MEMORY BUTTONS:** The six memory buttons are used to store preferred broadcast stations in radio memory. To store a station, tune to desired station, push memory button in and hold for approximately two seconds until station sound returns, then release button. Repeat process for each memory button. Once a station is stored in memory, pushing a memory button for less than two seconds will cause radio to turn to stored station. All six memory buttons will store a station on AM, FM1 or FM2 for a total of 18 storable radio stations.
- O. **AM/FM:** Each successive push, when in radio mode, will select AM, FM1 or FM2 as indicated by band indicator in display window.
- P. **VOLUME:** Push right (+) side of VOLUME button to increase volume. Push left (-) side to decrease volume. If VOLUME button is held to the right or left, the volume will continuously increase or decrease (bars in display will show relative volume) until button is released.

NOTE: If the VOLUME button is set above a preset listening level when ignition switch is turned off, when ignition switch is turned back on, the volume will return to a nominal listening level. However, if radio power is turned off with the POWER button before ignition is turned off, volume will return to the position it was set at previously, at when radio power is switched back on.

Tape Error Messages

The PAC radio is designed to diagnose certain inoperative cassette player conditions. The error codes are as follows:

- Error 0—Communication error between radio controller and tape controller.
- Error 1—Possible tape cartridge jam.
- Error 2—Tape eject or load concern.

Cassette Tape Player

CAUTION: Before turning off radio or the ignition of vehicle, always eject any cassette being played. Leaving the tape mechanism stopped while a tape is engaged can result in damage to the tape, pinch roller or capstan.

Insert the tape cassette, open edge to the right, to play (radio on, ignition in RUN or ACC position). Adjust volume, tone and speaker balance as for radio programs. At the end of the tape, the cassette automatically reverses and plays the other side of the tape. At any time the tape transport mechanism can be changed to play the other side of the tape by pressing the REVERSE button (ESC).

The Dolby® System is a noise reduction system manufactured under license from Dolby Laboratories. Dolby® and the double-D symbol® are trademarks of Dolby Laboratories Licensing Corporation.

Operating Precautions

NOTE: Do not leave a tape cassette engaged in the tape player slot when not in use. Remove it completely to permit the slot door to close and keep out airborne dirt.

When inserting a tape cassette into the tape slot, it should be firmly pushed in and down to ensure that it is properly seated. To play a full tape, insert the cassette so the empty hub of the cassette goes into the slot first.

Take care to protect the open edge of the cassette from damage, dirt, oil and grease. When not in use, store cassettes in their protective cases with hub locks in place. Otherwise, there will be a risk of having the tape loosen on its hubs, which could cause the tape to spill or jam in the player. If a cassette is found with loose tape, ensure it is rewound firmly around the hubs before using it. Never try to open a cassette or try to pull the tape out of it. To avoid tape damage, do not use cassettes that have been soiled by liquid spills.

Cassette Irregularities

Cassette tapes can vary in performance and size, resulting in occasional concerns with certain specific cassettes.

If any one cassette gives continual trouble because of this, it is best to discontinue use.

DESCRIPTION AND OPERATION (Continued)

For best results, use cassette tapes with no more than 90 minutes of playing time. The thinness of the tapes used in C120 and C180 cassettes makes the tape more likely to stretch and break. A stretched tape will result in poor sound quality.

Tape Player Will Not Accept Cartridge, Eats Tape, Plays Too Fast or Too Slow, Etc. (AM and FM Operating Properly)

- Ensure cassette has not come to the end of the tape.
- Check operation of the tape player by using a known good cassette / cartridge.
- If the condition is not corrected by the substitution of a known good cassette / cartridge, the radio chassis must be removed and sent to an authorized service facility for service.

Temperature Extremes

Do not expose tape cassettes to intense sunlight or other temperature extremes. If they do become exposed to high or low temperatures, allow each cassette to reach a moderate temperature before playing. During cold weather, it is advisable to take cassettes indoors overnight to protect them.

In extremely cold weather, the tape player may need a few minutes to warm up before delivering full sound quality.

Compact Disc Player

The following is a description of the various controls.

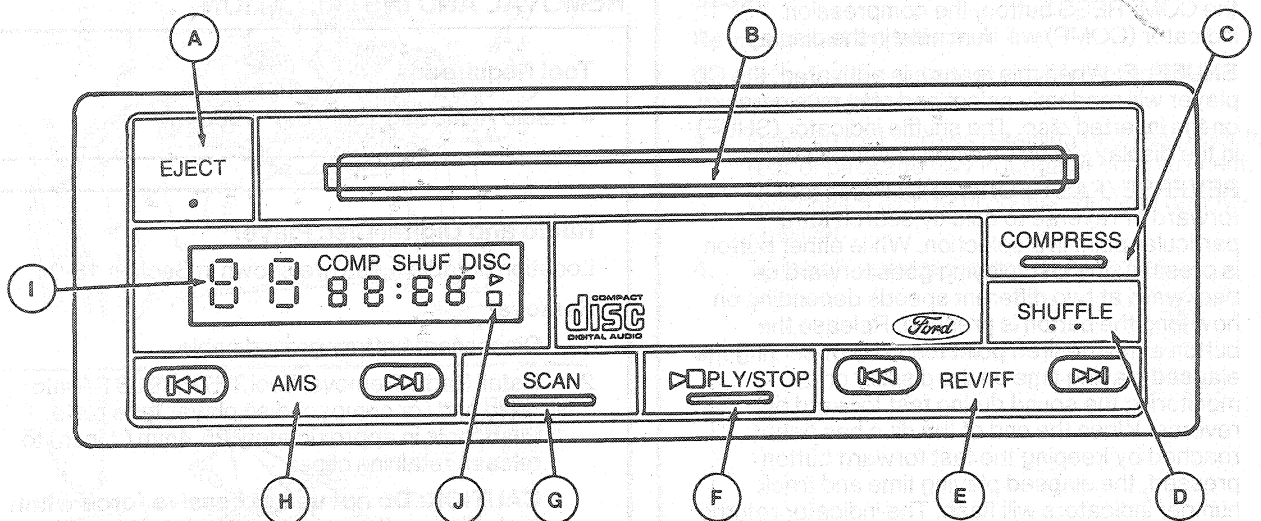

K18588-A

NOTE: The compact disc player operates when the high level or JBL Audio System is on and a disc is inserted (label-side up). Handle the disc by its edge only.

NOTE: Three inch compact disc singles are not recommended for use with the Ford Compact Disc Player.

NOTE: The CD player has heat protection circuitry to protect the laser diode. If the temperature of the player reaches 80°C (176°F), the heat detection circuit will shut off the player and "H" will appear in the display. When the temperature is within normal operating range the "H" indicator will turn off and the CD player will again be operational.

WARNING: USE OF CONTROLS AND ADJUSTMENTS OR PERFORMANCE OF PROCEDURES OTHER THAN THOSE SPECIFIED MAY RESULT IN HAZARDOUS RADIATION EXPOSURE.

THE USE OF OPTICAL INSTRUMENTS WITH THIS PRODUCT WILL INCREASE EYE HAZARD AS THE LASER BEAM USED IN THE COMPACT DISC PLAYER IS HARMFUL TO THE EYES. DO NOT ATTEMPT TO DISASSEMBLE THE CASE. REFER SERVICING TO QUALIFIED PERSONNEL ONLY.

Once a disc is inserted, the operation of the disc will override that of the cassette player or radio. The volume, tone and fader controls on the radio are used to control the sound of the compact disc player.

A. EJECT: This button ejects the disc and stops the unit. The radio or cassette tape will resume playing.

DESCRIPTION AND OPERATION (Continued)

- B. **DISC SLOT:** When inserted, the disc automatically loads into the unit and play starts at the beginning of the first selection. The play indicator illuminates and the number "1" (track) and "0: 00" (elapsed time) are shown on the digital display (I). When the disc reaches the end, the disc player automatically returns to the beginning of the disc and resumes playing.

NOTE: Once a disc is inserted, the disc opening door locks to prevent the accidental insertion of a second disc.

- C. **COMPRESS:** Because of the wide dynamic range of the compact disc player, soft passages may be difficult to hear under certain driving conditions while maintaining a reasonable volume level in the louder passages. The compression feature will bring the softer and louder passages closer together for a more consistent listening level. To activate the compression feature, press the COMPRESS button, the compression indicator (COMP) will illuminate in the display.
- D. **SHUFFLE:** When this feature is activated, the CD player will randomly select and play music tracks on the inserted disc. The shuffle indicator (SHUF) in the display will be on when shuffle is selected.
- E. **REVERSE / FAST FORWARD:** Press fast forward or reverse to quickly search for a particular point in a selection. While either button is pressed, the disc playing goes forward or backward at two different speeds depending on how long the button is pressed. Release the button at the desired point found by observing the elapsed playing time on the display or by monitoring the sound during fast forward or reverse. When the end of the disc has been reached by keeping the fast forward button pressed, the elapsed playing time and track number indicators will flash. The indicator returns to normal display when the reverse button is pressed. A "1" and "0: 00" will appear when the beginning of the disc is reached by pressing the reverse button.
- F. **PLAY / STOP:** When a disc is loaded the unit automatically enters the play mode (play indicator illuminates). To stop temporarily, press the PLAY / STOP button. The stop indicator (J) in the display illuminates and operation returns to the radio or tape mode. To resume CD play, press this button once again. If the ignition key is turned OFF during play but is set to RUN or ACCESSORY at any time later, play will resume.
- G. **SCAN:** When this feature is activated, the CD player will scan up to next selection and play a five second audition, then advance to next selection unless button is repressed. During scan mode, elapsed time indicators will activate and track number will flash on display.
- H. **AMS CONTROL:** To search for a previous or later selection, press the left or right side of the AMS control respectively during either the play or stop mode.

- I. **DISPLAY:** The digital display shows the track number, elapsed time, compression on, shuffle, disc in, play and stop indicators.

DIAGNOSIS AND TESTING

Refer to Section 15-00.

WARNING: USE ONLY PROPERLY INSTALLED FCC APPROVED RADIO TRANSMITTING EQUIPMENT. USE OF OTHER TRANSMITTING EQUIPMENT MAY CAUSE THE VEHICLE TO MALFUNCTION OR STALL. IF THE ENGINE STALLS, POWER BRAKE AND POWER STEERING ASSIST WILL STOP. CONSULT YOUR AUTHORIZED DEALER BEFORE INSTALLING ANY RADIO TRANSMITTER.

REMOVAL AND INSTALLATION

Tool Required:

- Radio Removing Tool T87P-19061-A

Radio and Digital Disc Player

Location of radio fuses are shown in Section 18-01.

Removal

1. Disconnect battery ground cable.
 2. Install Radio Removal Tool T87P-19061-A into radio and / or compact disc player face plate. Push tools in approximately 25.4mm (1 inch) to release retaining clips.
- CAUTION: Do not use excessive force when installing radio removing tool as this will damage retaining clips, making radio removal difficult and may cause damage.**
3. Apply a light spreading force on tools and pull radio and / or compact disc player out of dash.
 4. Disconnect wiring connectors and antenna cable.

Installation

1. Connect wiring connectors and antenna cable to radio.
2. Slide radio into instrument panel ensuring that radio and / or compact disc player rear bracket is engaged on upper support rail.
3. Push radio and / or compact disc player inward until retaining clips are fully engaged.
4. Connect battery ground cable. Test radio and / or compact disc player for operation.

REMOVAL AND INSTALLATION (Continued)

Premium Sound Amplifier (Low and High-Level)

Sedan

Removal and Installation

1. Remove amplifier trim cover.
2. Remove two (low-level amplifier) or four (high-level amplifier) screws retaining amplifier to rear of package tray in luggage compartment.
3. Disconnect electrical connectors and remove amplifier.
4. To install, reverse Removal procedure.

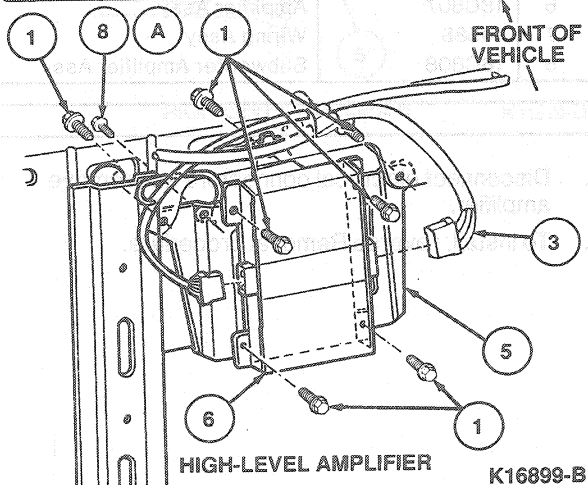
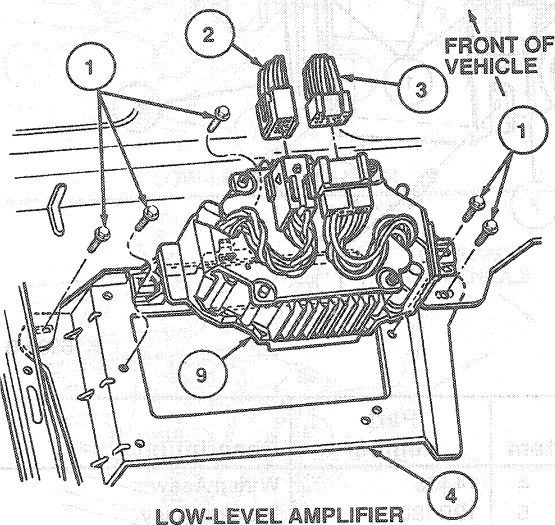

REMOVAL AND INSTALLATION (Continued)

Item	Part Number	Description
1	56910-S36	Screw (5 Req'd, 7 Req'd)
2	19B113	Wiring Assy
3	14405	Wiring Assy
4	18B860	Bracket Assy
5	19B180	Bracket Assy
6	18C807	Amplifier Assy
7	14588	Wiring Assy
8A	N801846-53M6	Screw
9	18B849	Amplifier Assy
A		Tighten to 3.4-4.8 N·m (30.1-42.5 Lb·In)

JBL Amplifier

Sedan

Removal and Installation

1. From inside luggage compartment remove amplifier trim cover.
2. Remove four screws retaining each amplifier to rear of package tray in luggage compartment.
3. Disconnect electrical connectors and remove amplifier.
4. To install, reverse Removal procedure.

REMOVAL AND INSTALLATION (Continued)

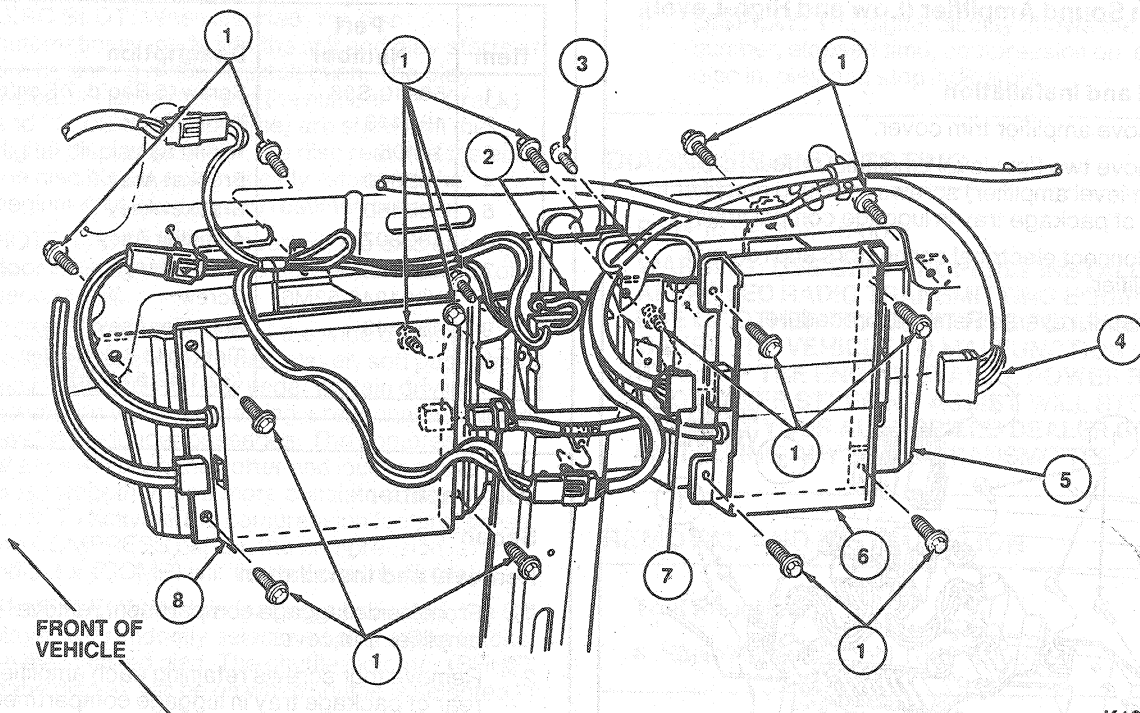

K16900-B

Item	Part Number	Description
1	56910-S36	Screw (16 Req'd)
2	19A087	Choke and Capacitor Assy
3	N801846-S36MG	Screw (1 Req'd)

(Continued)

Item	Part Number	Description
4	14405	Wiring Assy
5	19B180	Bracket Assy
6	18C807	Amplifier Assy
7	14588	Wiring Assy
8	18C808	Subwoofer Amplifier Assy

Station Wagon

Removal and Installation

1. Remove LH rear quarter trim panel. Refer to Section 01-05.
2. Reach into upper quarter panel area and hold amplifier assembly while removing two (low-level amplifier) or three (high-level amplifier) mounting screws.

3. Disconnect electrical connectors and remove amplifier.
4. To install, reverse Removal procedure.

REMOVAL AND INSTALLATION (Continued)

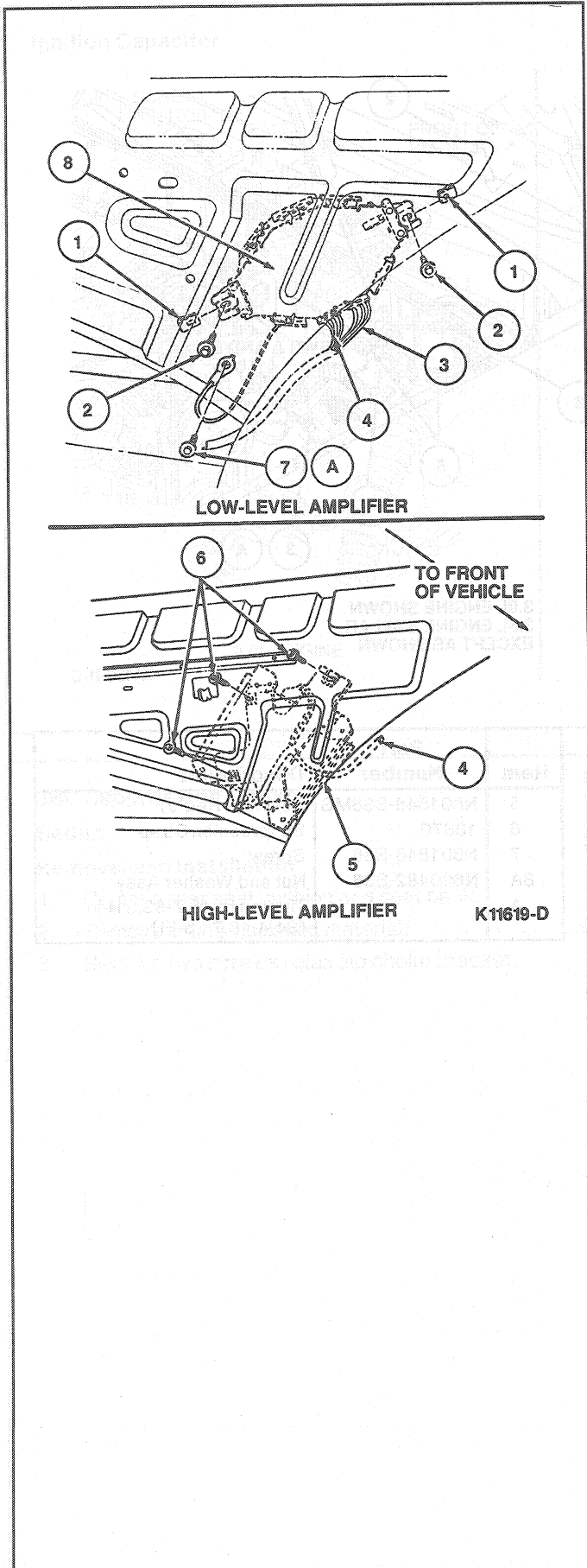

Item	Part Number	Description
1	N802538-S100	Nut (2 Req'd)
2	N802141-S36	Screw (2 Req'd)
3	14405	Wiring Assy
4	19B113	Wiring Assy
5	18T805	Amplifier Assy
6	56910-S36	Screw
7A	N801846-S36MG	Screw
8	18P849	Amplifier Assy
A		Tighten to 3.4-4.8 N·m (30.1-42.5 Lb·In)

Radio Interference Suppression

The following illustrations show the radio interference suppression equipment installations.

Item	Part Number	Description
1	N802538-S100	Nut (2 Req'd)
2	N802141-S36	Screw (2 Req'd)
3	14405	Wiring Assy
4	19B113	Wiring Assy
5	18T805	Amplifier Assy
6	56910-S36	Screw
7A	N801846-S36MG	Screw
8	18P849	Amplifier Assy
A		Tighten to 3.4-4.8 N·m (30.1-42.5 Lb·In)

REMOVAL AND INSTALLATION (Continued)

(Continued) REMOVAL AND INSTALLATION (Continued)

Engine and Hood Ground Strap

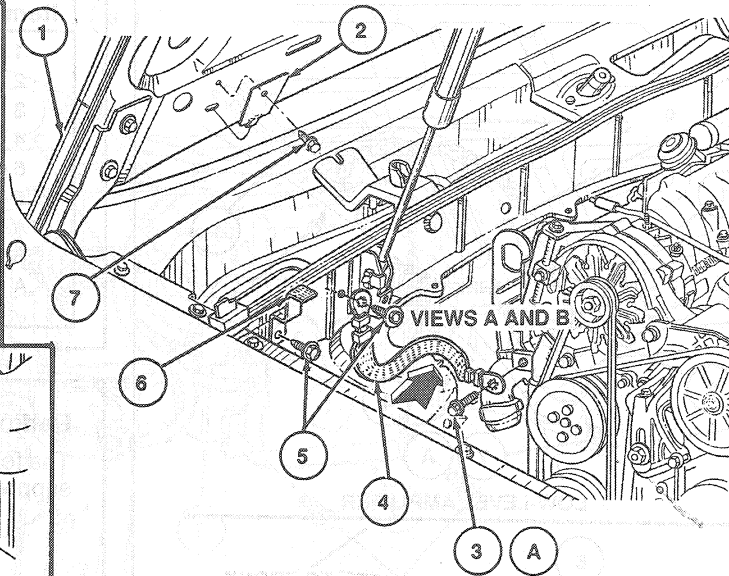
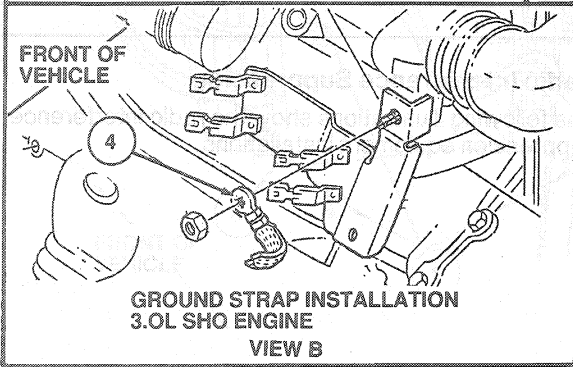
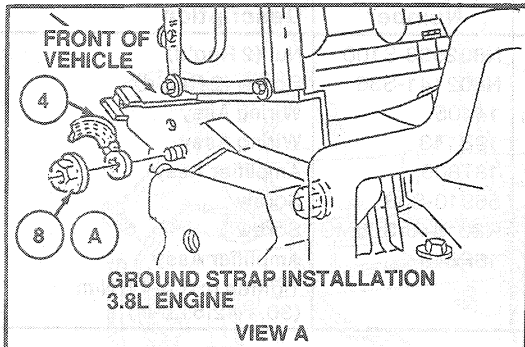

3.0L ENGINE SHOWN
3.8L ENGINE SIMILAR
EXCEPT AS SHOWN

K13041-C

Item	Part Number	Description
1	—	Hood
2	19B136	Suppression Bracket Choke
3A	N605799-S36	Bolt
4	19A095	Ground Strap

Item	Part Number	Description
5	N801846-S36MG	Screw (2 Req'd)
6	18870	Suppression Strap
7	N801846-S36	Screw
8A	N620482-S36	Nut and Washer Assy
A		Tighten to 46.7-63.3 N-m (34.4-46.7 Lb-Ft)

(Continued)

Station Wagon

Temporarily Installed

- Remove the radio and tape chassis from the vehicle.
- Remove the radio and tape chassis from the vehicle.

REMOVAL AND INSTALLATION (Continued)

Ignition Capacitor

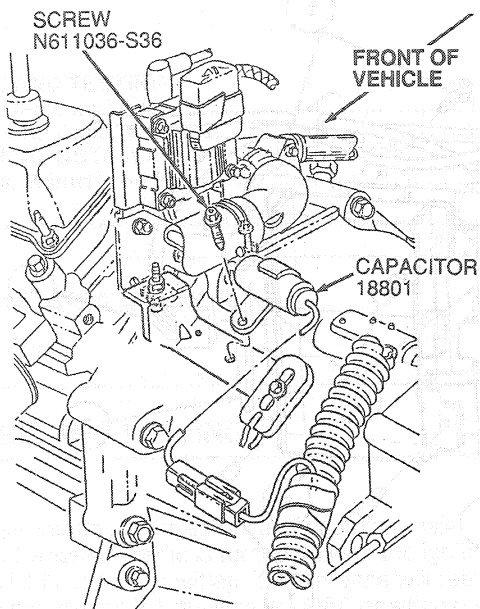

3.0L ENGINE

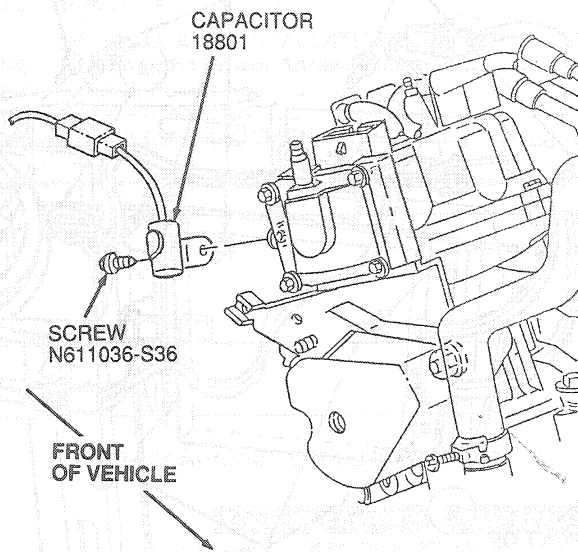

3.8L ENGINE

K13042-B

JBL Suppression Choke

Sedan

Removal and Installation

1. Remove rear seat cushion and seat back.
2. Remove sound insulation material.
3. Remove two screws retaining choke bracket.

4. Remove ground wire screw.
5. Remove amplifier trim cover from inside luggage compartment.
6. Disconnect electrical connectors and remove choke and bracket assembly.
7. To install, reverse Removal procedure.

REMOVAL AND INSTALLATION (Continued)

REMOVAL AND INSTALLATION (Continued)

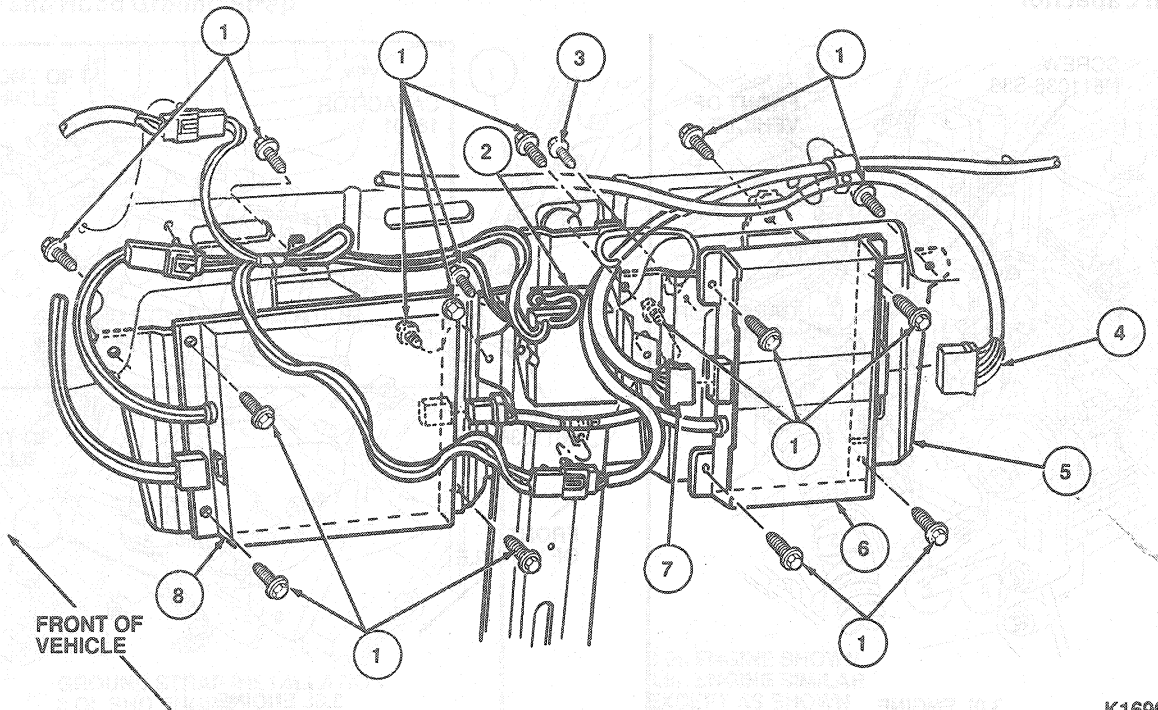

K16900-B

Item	Part Number	Description
1	56910-S36	Screw
2	19A087	Choke and Cap Assy
3	N801846-S36MG	Screw

Item	Part Number	Description
4	19B113	Wiring Assy
5	19B180	Bracket Assy
6	18C807	Amplifier Assy
7	18C808	Subwoofer Amplifier Assy

(Continued)

CLEANING

Cassette Tape Player

Head

The playback head, capstans and pinch rollers may accumulate an oxide residue as the tape passes through the components while playing. Depending on the quality used, more or less oxide will accumulate. Oxide accumulation can cause weak or wavering sound and damage to the cassette tape and / or player.

It is recommended for best performance that the tape player be cleaned after every 10 to 12 hours of playing time with a Ford Cassette Cleaning Cartridge or equivalent.

CAUTION: The use of other cassette cleaners is not recommended. Damage to the cassette player could result.

SPECIFICATIONS

TORQUE SPECIFICATIONS

Description	N-m	Lb-In
Amplified Assy Screw	3.4-4.8	30.1-42.5
Ground Strap Bolt and Ground Strap Nut	46.7-63.3	34.4-46.7 (Lb-Ft)

SPECIAL SERVICE TOOLS

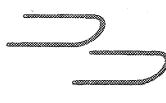
Tool Number / Description	Illustration
T87P-19061-A Radio Removing Tool	 T87P-19061-A