

# SECTION 14-02A Generator, Integral Rear Mount Regulator—Internal Fan Type

SUBJECT	PAGE	SUBJECT	PAGE
<b>DESCRIPTION AND OPERATION</b>		<b>DISASSEMBLY AND ASSEMBLY</b> .....	14-02A-15
Generator Circuit.....	14-02A-2	<b>REMOVAL AND INSTALLATION</b>	
<b>DIAGNOSIS AND TESTING</b>		Generator .....	14-02A-14
Battery Drain Test .....	14-02A-3	Regulator .....	14-02A-14
Charging System Tests.....	14-02A-4	<b>SPECIAL SERVICE TOOLS</b> .....	14-02A-15
Diagnosis Charts.....	14-02A-8	<b>SPECIFICATIONS</b> .....	14-02A-15
Regulator S and/or I Circuit Test .....	14-02A-7	<b>VEHICLE APPLICATION</b> .....	14-02A-1
Visual Inspection.....	14-02A-2		

## VEHICLE APPLICATION

Taurus / Sable Vehicles with 3.0L and 3.8L EFI Engines.

## DESCRIPTION AND OPERATION

The electrical charging system is a negative ground system consisting of an integral generator / voltage regulator (IGR), charge indicator, storage battery, and the necessary wiring and cables. Refer to the Electrical and Vacuum Troubleshooting manual for schematics and locations of components and wiring.

With the ignition key in the RUN position, voltage is applied through the charge indicator lamp 'I' circuit to the voltage regulator. This turns the regulator on allowing current to flow from the battery sense 'A' circuit to the generator field coil. When the engine is started, the generator begins to generate alternating (AC) current which is converted to direct (DC) current by the rectifier assembly internal to the generator. This current is then supplied to the vehicle's electrical system through the output connector Battery Positive Voltage (B+) located on the rear of the generator.

Once the generator begins generating current, a voltage signal is taken from the generator stator and fed back to the regulator 'S' circuit, turning off the charge indicator.

With the system functioning normally, the generator output current is determined by the voltage at the 'A' circuit (battery sense voltage). The 'A' circuit voltage is compared to a set voltage internal to the regulator, and the regulator controls the generator field current to maintain proper generator output. The set voltage will vary with temperature and is typically higher in the winter than in the summer, allowing for better battery recharge in the winter and reducing the chance of overcharging the battery in the summer.

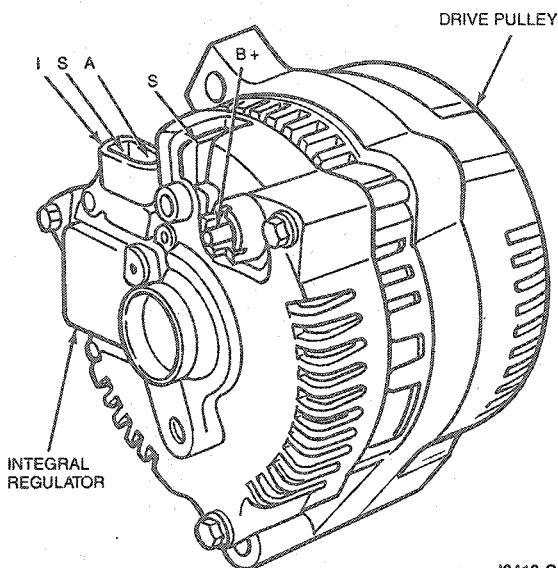

J3419-C

DESCRIPTION AND OPERATION (Continued)

Generator Circuit

Circuit Description

Battery Positive Voltage (B+) Output

The generator output is supplied through the Battery Positive Voltage (B+) output connection to the battery and electrical system.

'I' Circuit

The 'I' circuit, or ignition circuit, is used to turn on the voltage regulator. This circuit is powered up with the ignition key in the RUN position. This circuit is also used to turn the indicator on if there is a fault in the charging system operation or associated wiring circuits.

'A' Circuit

The 'A' circuit, or battery sense circuit, is used to sense the battery voltage. This voltage is used by the regulator to determine the generator output. This circuit is also used to supply power to the generator field coil. This circuit is connected back to the load distribution point and is a protected circuit.

'S' Circuit

The 'S' circuit, or stator circuit, is used to feedback a voltage signal from the generator to the regulator. This voltage, typically 1/2 battery voltage, is used by the regulator to turn off the indicator.

Generator Circuit

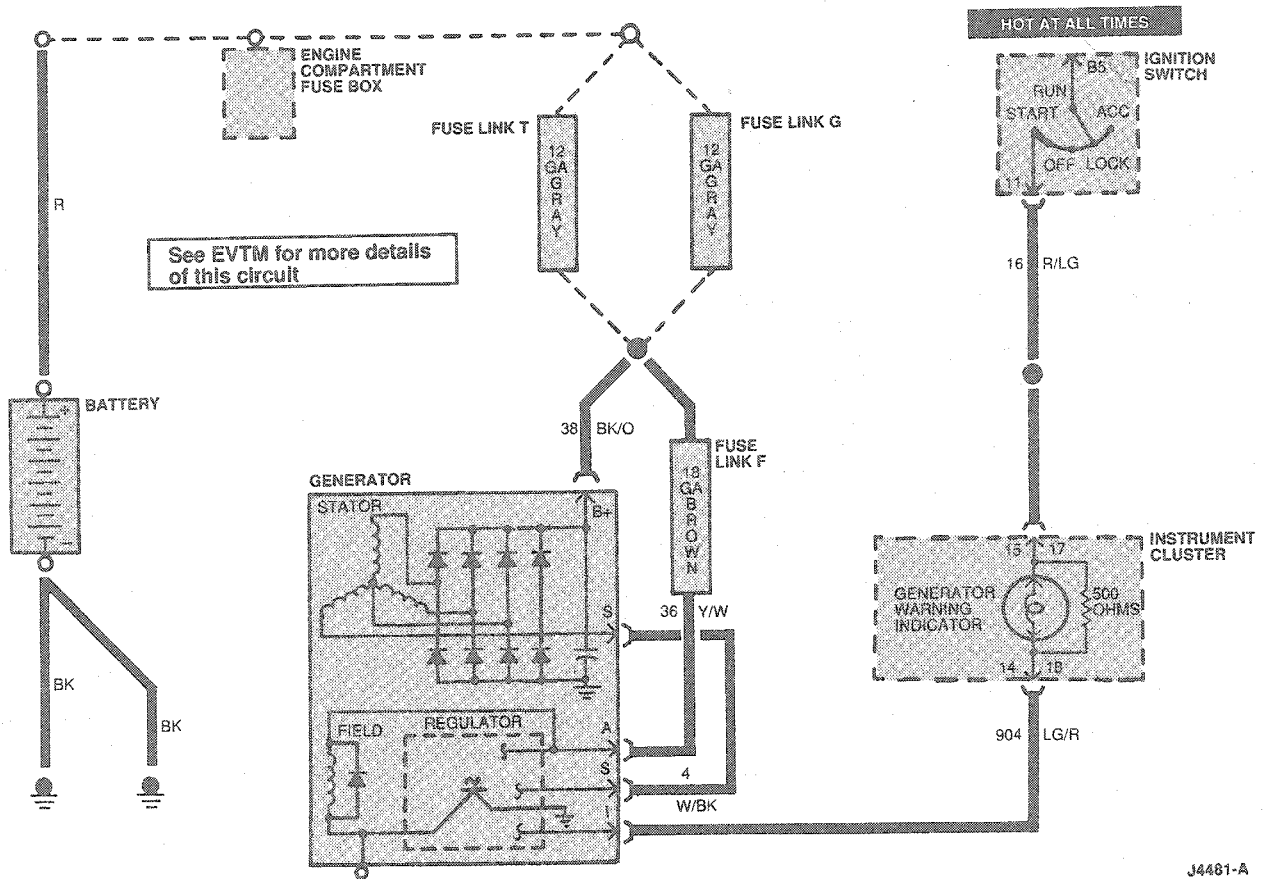

J4481-A

DIAGNOSIS AND TESTING

Before performing charging system tests on the vehicle, note conditions such as: slow cranking, discharged battery, generator / battery charge indicator stays on with engine running or generator / battery charge indicator does not light with ignition switch in RUN and engine not running. This information will aid in isolating the part of the system causing the symptom.

Visual Inspection

Preliminary checks to the charging system should be made regardless of the inoperable condition. These checks include:

1. Check battery posts and cable terminals for clean and tight connections. Clean the posts and the cables to ensure good electrical contact.

## DIAGNOSIS AND TESTING (Continued)

2. Check for secure connections at the generator output, regulator, and engine ground connections. Also check the connection at the load distribution point.
3. Check the generator belt to ensure proper tension and no slip between the generator pulley and the belt.
4. Check the fuses / fuse links to the generator to ensure that they are not burned or damaged. This condition, resulting in an open circuit or high resistance, can cause erratic or intermittent charging system concerns.

### Isolating the Concern

Battery, starting system and lamp system problems can be caused by poor charging system performance. It is also reasonable to suspect the charging system if an overload condition has occurred in another area of the electrical system.

To avoid guesswork, it is necessary to isolate battery, charging system, and electrical circuits to correctly identify the area where the difficulty lies. Check the battery first before beginning any electrical system diagnosis. The battery must be in proper state of charge and operation before the other areas of the electrical system can perform normally.

### Battery Check

Check battery to see if it has the capacity and ability to accept and hold a charge. Refer to Section 14-01. If battery is OK, the charging system should then be checked to see that it performs its function of keeping the battery charged.

The battery capacity, specific gravity and cell comparison test (non-maintenance free batteries only) will determine the ability of a battery to accept and hold a charge. If the battery does not meet specification, replace it with a new, fully charged battery before further diagnosis of other areas of the electrical system.

If the battery meets required specifications, it should be fully charged before proceeding with the diagnosis of other electrical system components.

### Charging System Check

The charging system test should be performed before testing any individual charging system components. The component tests will determine the type of component service required.

Test instruments used in the charging system test are a voltmeter (0-20- or 0-30-volt scale) and an ohmmeter.

**WARNING: SPECIAL CARE SHOULD BE TAKEN WHEN USING THE OHMMETER NEAR "HOT" CIRCUITS. DISCONNECT THE COMPONENT TO BE CHECKED ON THE BATTERY CABLES TO PREVENT DAMAGE TO THE OHMMETER.**

## Battery Drain Test

### Tools Required:

- Rotunda Digital Volt-Ohmmeter 007-00001

Check for current drains on the battery in excess of 100 milliamps with all the electrical accessories off and the vehicle at rest. Current drains can be tested one of three ways:

1. Connect a 12-volt test lamp in series with battery positive terminal. If lamp glows, then a drain exists.
2. Use an in-line ammeter between the battery positive or negative post and its respective cable.
3. Use a clamp-on current probe to the battery positive or negative cable. Make sure that the probe is properly calibrated to prevent false readings.

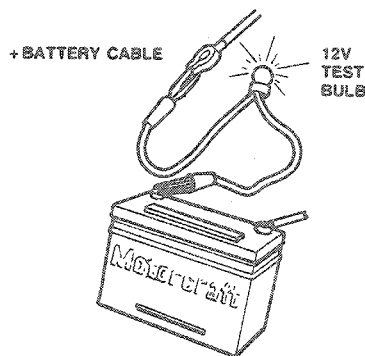

Typically, a drain of approximately one amp can be attributed to an underhood lamp, glove compartment lamp, or rear deck lid lamp staying on continually. Other component failures or wiring shorts may be located by selectively pulling fuses or disconnecting fuse links to pinpoint the location of the current drain. When the current drain is found, the test lamp will go out or the meter reading will fall to an allowable level. If the short is still not located, after checking all the fuses and fuse links, the drain may be due to the generator / regulator. Disconnect the generator output wire from the output stud and the regulator connector. If this eliminates the drain, check the charging system to locate the concern.

**NOTE:** A voltmeter is sometimes used for this test but it will react to a very small normal drain caused by "always-on" electronic systems such as starter interlock, anti-theft alarm, illuminated entry, etc, which cause no concern. The test lamp shows only drains which are large enough to cause a concern.

**NOTE:** For vehicles with electronic instrument cluster or message center, when the Message Center is initially powered up (after a battery disconnect), the Message Center "computer" may be energized for as long as one minute causing a 0.25 amp current draw before returning to the normal 0.010-0.012 amp current draw. Therefore, it is important to allow at least one minute to pass (after ammeter hookup) before observing any current measurements.

## DIAGNOSIS AND TESTING (Continued)

### Charging System Tests

#### Tools Required:

- Rotunda Starting and Charging System Tester (VAT-40) 078-00005

#### Generator Output Test

When performing charging system tests, turn off all lamps and electrical components. Place transmission in PARK and apply parking brake.

**CAUTION:** Do not make jumper wire connections except as directed. Making improper jumper connections may damage the regulator or fuse links.

**NOTE:** Battery posts and cable clamps must be clean and tight to ensure accurate meter indications. Reference measurements to ground should be made to the battery negative post.

In order to check the charging system, the use of Rotunda Starting and Charging System Tester (VAT-40) 078-00005 or equivalent, is recommended.

1. Connect the positive and negative leads of the tester to battery.
2. Connect current probe to generator output lead (to measure generator output).
3. With the engine running at approximately 2000 rpm, set the load adjustment to determine generator output (with an ambient temperature of less than 27°C [80°F]).

**NOTE:** When measuring generator output, the tester can be connected to the battery positive or negative cable. In this case all electrical accessories must be turned off and 10-15 amps must be added to the reading on the tester to compensate for engine operation.

**NOTE:** Refer to the tester procedure manual for complete directions on checking the charging system.

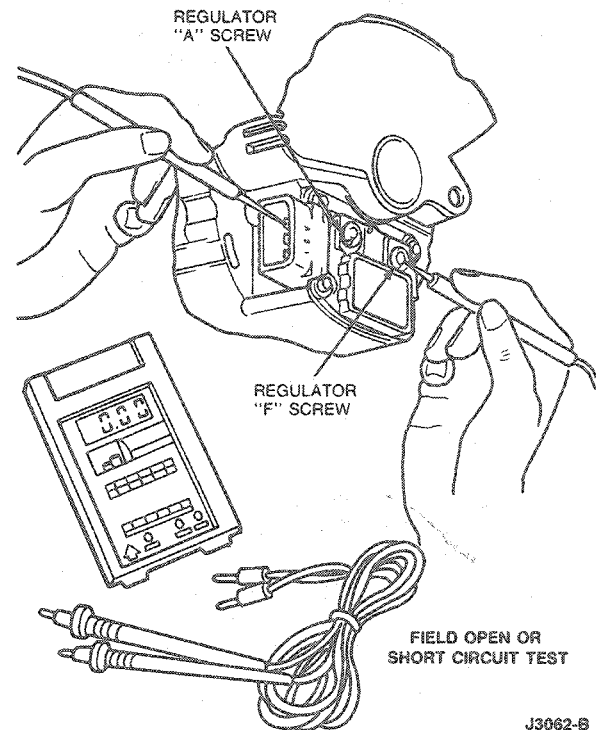

J3062-B

### Base Voltage Test

**NOTE:** Prior to running this test, turn the headlamps on for 10-15 seconds to remove any surface charge from the battery. Then, wait until the voltage stabilizes prior to performing the base voltage test.

1. With ignition switch in OFF position and no electrical loads operating, measure voltage across the battery positive and negative posts.
2. Record battery voltage reading shown on voltmeter scale. This reading is called base voltage.

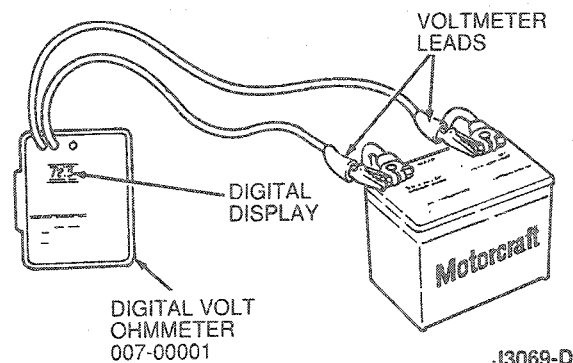

J3069-D

### No-Load Test

1. Connect a tachometer to engine.

## DIAGNOSIS AND TESTING (Continued)

2. Start engine and increase speed to approximately 1500 rpm. With no other electrical load (foot off brake pedal and doors closed), voltmeter pointer should move upward (increase) but not more than 3.0 volts above base voltage.

NOTE: The reading should be taken when voltmeter pointer stops rising. It may take a few minutes to reach this point. If voltage increases to proper level, perform Load Test. If the pointer continues to rise, perform the Over Voltage Tests. If the voltage does not rise to proper level, perform Under Voltage Tests.

### Load Test

1. With engine running, turn heater / air conditioner blower motor on (high speed) and headlamps on high beam.
2. Increase engine speed to approximately 2000 rpm. Voltmeter should indicate a minimum of 0.5 volt above base voltage. If not, perform Under Voltage Tests.

If above tests indicate proper voltage readings, charging system is operating normally. Proceed to the following tests if one or more of the readings is different than shown above and use a test lamp to check for battery drain.

### Over Voltage Tests

If voltmeter indicates more than 3.0 volts above base voltage in No-Load Test, follow these procedures:

1. With ignition switch in RUN position (engine not running), connect voltmeter negative lead to ground. Contact voltmeter positive lead first to generator output connection at load distribution point and then to regulator 'A' screw head.
2. If voltage difference between two locations is greater than 0.25 volt, service 'A' terminal wiring circuit to eliminate high resistance condition indicated by excessive voltage drop.
3. If over voltage condition still exists, check for loose regulator and generator grounding screws. Tighten loose regulator grounding screws to 1.7-2.8 N·m (16-24 lb-in).

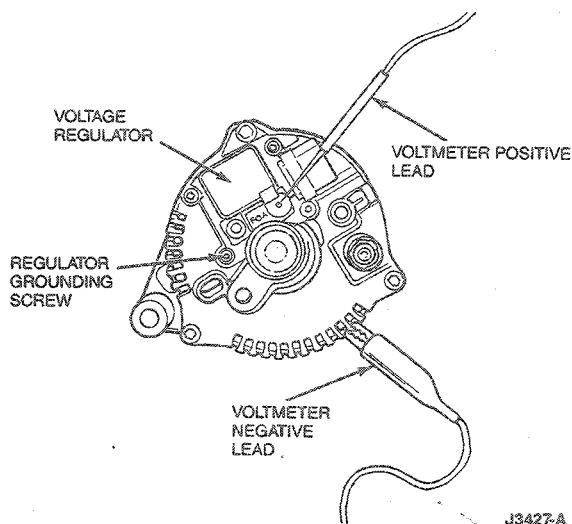

4. If over voltage condition still exists, connect voltmeter negative lead to ground. With ignition switch in OFF position, contact voltmeter positive lead first to regulator 'A' screw head and then to regulator 'F' screw head. Different voltage readings at two screw heads indicate a malfunctioning regulator grounded brush lead or a grounded rotor coil. Replace regulator / brush holder or generator assembly.
5. If same voltage reading (battery voltage) is obtained at both screw heads in Step 4 then there is no short to ground through the generator field / brushes. Replace the regulator.

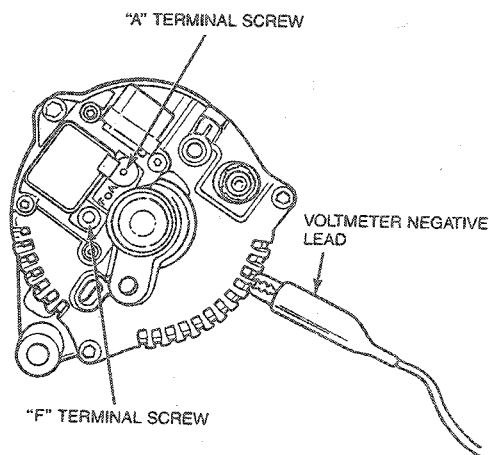

### Under Voltage Tests

If voltmeter does not indicate more than 0.5 volt above base voltage, follow these procedures:

**DIAGNOSIS AND TESTING (Continued)**

1. Disconnect wiring plug from regulator and connect an ohmmeter between regulator 'A' and 'F' terminal screws. The meter should indicate more than 2.4 ohms. If less than 2.4 ohms is indicated, check the generator for shorted rotor to field coil or shorted brushes. Replace the brush holder, if needed. Perform Load Test after servicing.

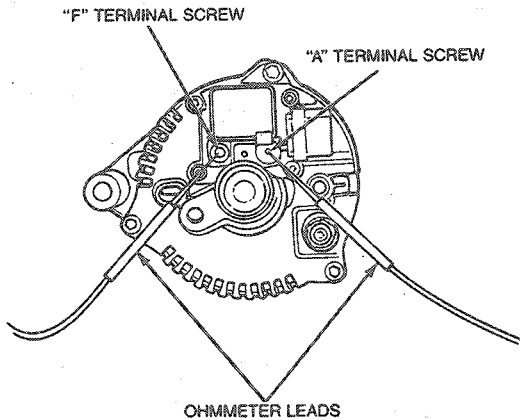

J3429-A

**CAUTION:** Do not replace the regulator if a shorted rotor coil or field circuit has been diagnosed. Regulator damage could result. Replace the generator assembly.

2. If above ohmmeter reading is greater than 2.4 ohms, connect regulator wiring plug and connect voltmeter negative lead to ground. Contact voltmeter positive lead to regulator 'A' terminal screw. The meter should indicate battery voltage. If there is no voltage, service the 'A' wiring circuit. Perform Load Test after servicing.

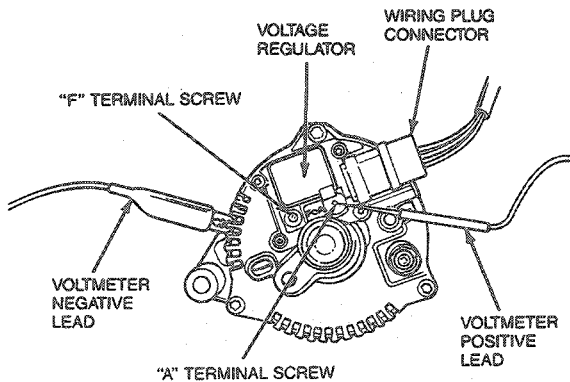

J3430-A

3. If voltmeter indicates battery voltage, connect voltmeter ground lead to ground. With the ignition switch in OFF position, contact voltmeter positive lead to regulator 'F' terminal screw. The meter should indicate battery voltage. If there is no voltage, replace generator assembly. Perform Load Test after servicing.

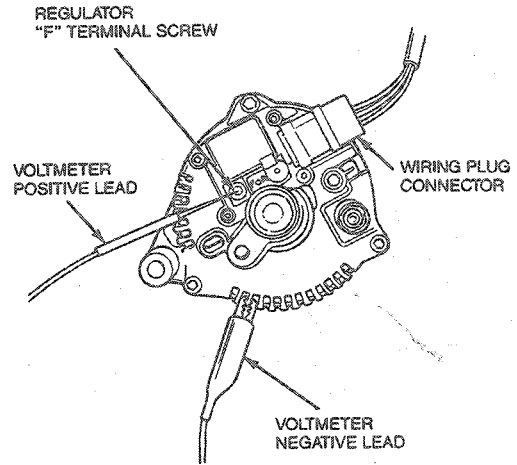

J3431-A

4. If voltmeter indicates battery voltage, connect voltmeter negative lead to ground. Turn ignition switch to RUN position (engine off) and contact voltmeter positive lead to regulator 'F' terminal screw. Refer to illustration under Step 3. The voltmeter should indicate 2 volts or less. If more than 2 volts is indicated, perform 'I' circuit tests and service 'I' circuit if needed. If 'I' circuit checks normal, replace regulator if needed and perform Load Test after servicing.

**DIAGNOSIS AND TESTING (Continued)**

5. If 2 volts or less is indicated, perform Load Test, but connect voltmeter positive to generator output stud. If voltage rises more than 0.5 volt above base voltage, service wiring from generator to load distribution point. Repeat Load Test, measuring voltage at battery cable clamps after servicing.

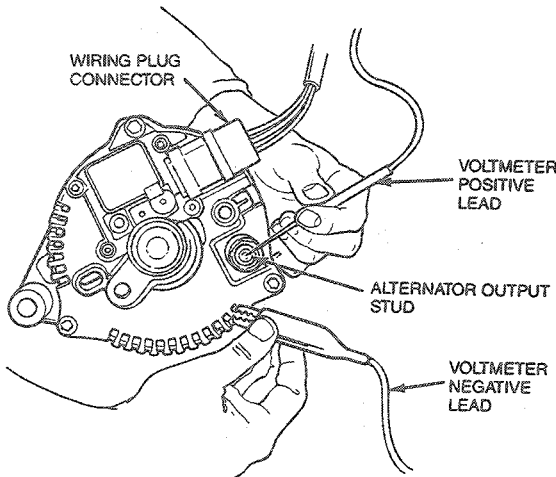

J3432-A

6. If voltage does not rise above 0.5 volt above base voltage, perform Load Test and measure voltage drop from the battery to the 'A' terminal of the regulator (with regulator connected). If the voltage drop exceeds 0.5 volt, service wiring from 'A' terminal to load distribution point.
7. If voltage drop does not exceed 0.5 volt, connect a jumper wire from the generator rear housing with regulator 'F' terminal. Repeat Load Test with voltmeter positive lead connected to the generator output stud. If voltage rises more than 0.5 volt, replace regulator.

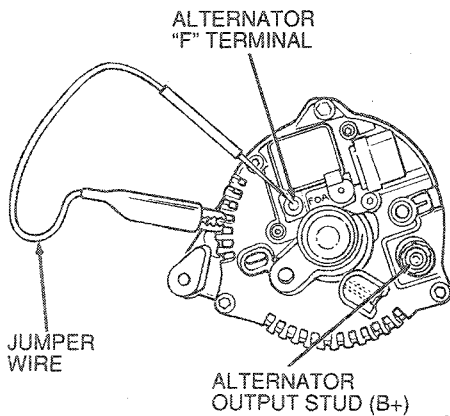

J3433-B

8. If voltage does not rise more than 0.5 volt, replace generator assembly.

**Regulator S and/or I Circuit Test**

1. Disconnect the wiring plug from the regulator. Connect a jumper wire from the regulator A terminal to the wiring plug A lead. Add a jumper wire from the regulator F screw to the generator rear housing.
2. With the engine idling and the voltmeter negative lead connected to ground, connect the voltmeter positive lead to the S terminal and then to the A terminal of the regulator wiring plug. The voltage at the S circuit should read approximately one-half that of the A circuit. If voltage readings are normal, remove the jumper wire. Replace the regulator and connect the wiring plug to the regulator. Repeat the Load Test after servicing.

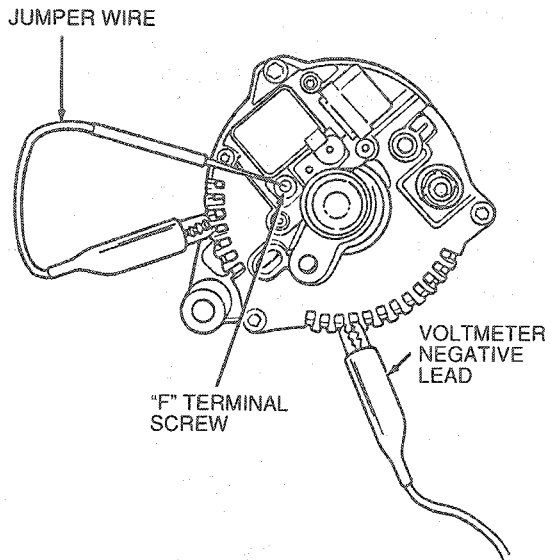
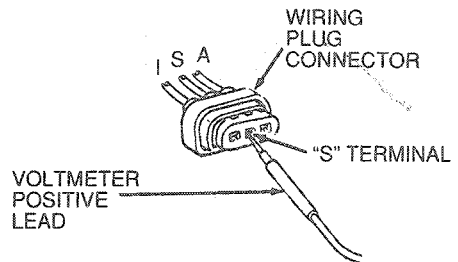

J3434-B

3. If no voltage is present, remove the jumper wire and service the faulty wiring circuit or generator.
4. Connect the voltmeter positive lead to the positive battery terminal. Connect the wiring plug to the regulator. Repeat Load Test.

**Fuse Link Continuity**

1. Ensure first that battery is OK, then turn on headlamps or any accessory. If headlamps or an accessory do not operate, fuse link is probably burned out.

**DIAGNOSIS AND TESTING (Continued)**

2. On some vehicles there are several fuse links. Use same procedure as in Step 1 to test fuse link that protects vehicle equipment.
3. To test fuse link that protects generator, ensure that battery is OK, then check with a voltmeter for voltage at BAT terminal of generator and 'A' terminal of voltage regulator. No voltage indicates that fuse link is probably burned out. Refer to Section 18-01 for fuse link replacement procedures.

**Field Circuit Drain**

Connect the voltmeter negative lead to the generator rear housing for all of the following voltage readings:

1. With ignition switch turned to OFF position, contact voltmeter positive lead to regulator 'F' terminal screw. The meter should indicate battery voltage if system is operating normally. If less than battery voltage is indicated, proceed with Step 2 to find cause of current drain.
2. Measure voltage at 'I' terminal (ignition OFF). If voltage is indicated, service 'I' circuit from ignition switch to eliminate voltage source.
3. If no voltage was indicated in Step 2, contact voltmeter positive lead to wiring plug 'S' terminal. No voltage should be indicated. If no voltage is indicated, replace the regulator.
4. If voltage was indicated in Step 3, disconnect the one pin 'S' terminal connector. Again, contact voltmeter positive (+) lead to regulator wiring plug 'S' terminal. If voltage is indicated, service 'S' lead wiring to eliminate voltage source. If no short is found, replace generator assembly.

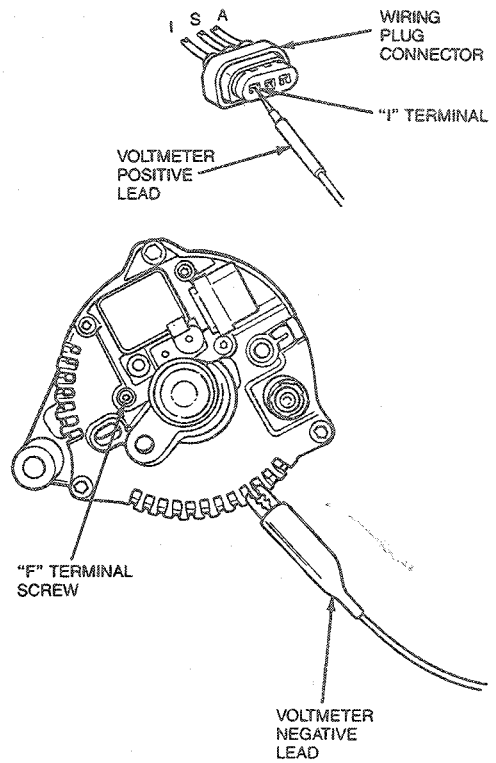

J3435-A

**Diagnosis Charts**

Continue through Diagnosis charts until service is completed. Then, test system again to see if service has corrected the condition.

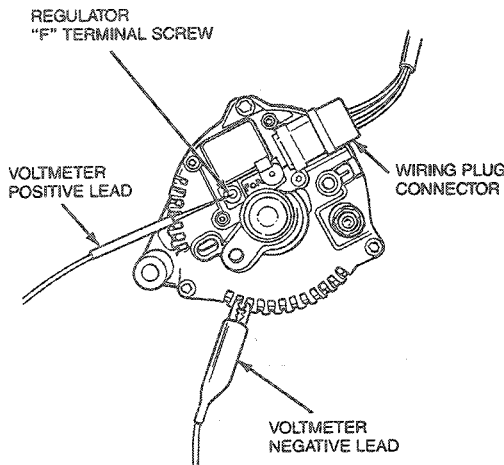

J3431-A

**PINPOINT TEST A: CHARGE INDICATOR — DIAGNOSIS**

TEST STEP		RESULT	ACTION TO TAKE
A1	LAMP CHECK NO. 1		
	<ul style="list-style-type: none"> <li>● Engine OFF.</li> <li>● Key in OFF position.</li> <li>● Is charge indicator on?</li> </ul>	Yes No	GO to A4. GO to A2.



**DIAGNOSIS AND TESTING (Continued)**

**PINPOINT TEST A: CHARGE INDICATOR — DIAGNOSIS (Continued)**

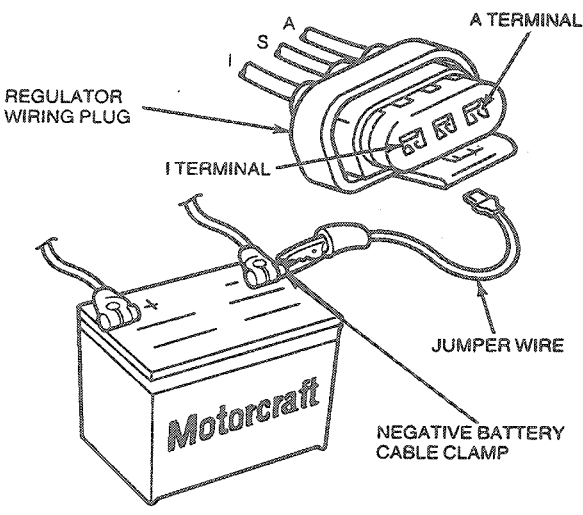
TEST STEP		RESULT	ACTION TO TAKE
A2	LAMP CHECK NO. 2		
	<ul style="list-style-type: none"> <li>● Engine OFF.</li> <li>● Key in RUN position.</li> <li>● Is charge indicator on?</li> </ul>	Yes No	GO to A3. GO to A5.
A3	LAMP CHECK NO. 3		
	<ul style="list-style-type: none"> <li>● Key in RUN position.</li> <li>● Engine running.</li> <li>● Is charge indicator on?</li> </ul>	No Yes	Lamp test complete. GO to A9.
A4	IMPROPER 'I' CIRCUIT WIRING		
	<ul style="list-style-type: none"> <li>● Key in OFF position.</li> <li>● Check for voltage at 'I' circuit.</li> <li>● Is voltage present?</li> </ul>	Yes No	CHECK for voltage feed from always hot circuit to I circuit. CHECK for damaged or improper wiring to indicator lamp at instrument cluster.
A5	INOPERATIVE INDICATOR LAMP		
	<ul style="list-style-type: none"> <li>● Key in ON position.</li> <li>● Engine OFF.</li> <li>● Disconnect regulator connector and ground 'I' terminal.</li> <li>● Is charge indicator on?</li> </ul>  <p style="text-align: right;">J3333-A</p>	Yes No	GO to A7. GO to A6.
A6	RESISTANCE / BULB TEST		
	<ul style="list-style-type: none"> <li>● Check for voltage at 'I' terminal of regulator connector.</li> <li>● Is voltage present?</li> </ul>	Yes No	CHECK for burned out indicator lamp or high resistance in lamp circuit. CHECK for an open in 'I' circuit wiring.

DIAGNOSIS AND TESTING (Continued)

PINPOINT TEST A: CHARGE INDICATOR — DIAGNOSIS (Continued)

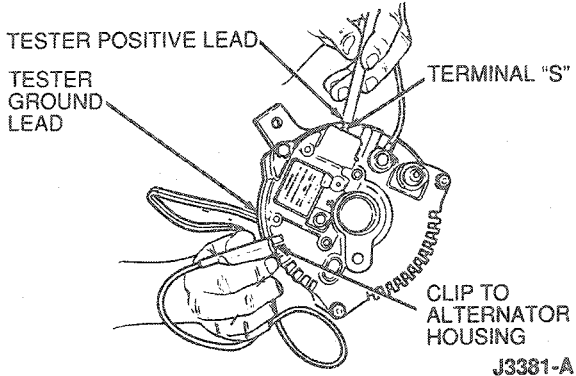
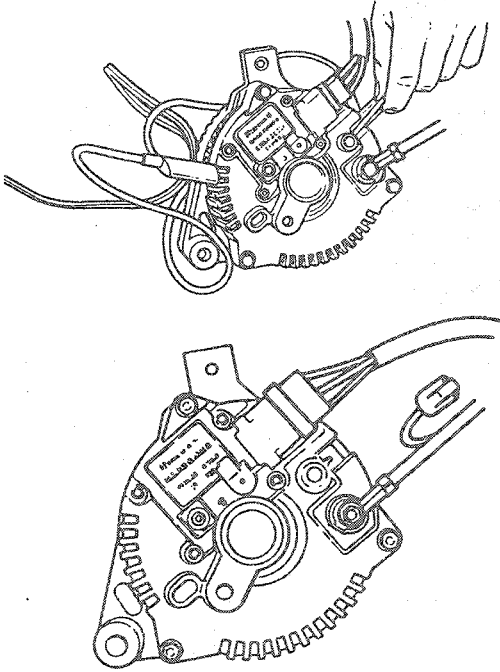
TEST STEP	RESULT	ACTION TO TAKE
<p><b>A7 STATOR VOLTAGE FAULT</b></p> <ul style="list-style-type: none"> <li>● Reconnect voltage regulator.</li> <li>● Engine OFF.</li> <li>● Check voltage 'S' terminal.</li> <li>● Is voltage present?</li> </ul>  <p>TESTER POSITIVE LEAD TESTER GROUND LEAD TERMINAL "S" CLIP TO ALTERNATOR HOUSING J3381-A</p>	<p>Yes No</p>	<p>▶ GO to A8. ▶ REPLACE regulator.</p>
<p><b>A8 PINPOINT STATOR VOLTAGE FAULT</b></p> <ul style="list-style-type: none"> <li>● Disconnect 1-pin stator connector.</li> <li>● Key in ON position.</li> <li>● Engine OFF.</li> <li>● Is charge indicator on?</li> </ul>  <p>J3382-A</p>	<p>Yes No</p>	<p>▶ REPLACE generator assembly. ▶ REPLACE regulator.</p>
<p><b>A9 OPEN CIRCUIT CHECK</b></p> <ul style="list-style-type: none"> <li>● Check voltage regulator, stator and Battery Positive Voltage (B+) output terminal connections for looseness or corrosion and service before checking voltage.</li> <li>● With key in ON position, engine off, check voltage at Battery Positive Voltage (B+) and 'A' terminal.</li> <li>● Is battery voltage present?</li> </ul>	<p>Yes No</p>	<p>▶ GO to A10. ▶ SERVICE wiring or fuse / fuse link for an open circuit between battery and generator or regulator.</p>

## DIAGNOSIS AND TESTING (Continued)

## PINPOINT TEST A: CHARGE INDICATOR — DIAGNOSIS (Continued)

TEST STEP		RESULT	ACTION TO TAKE
A10	VOLTAGE DROP TEST — 'A' TERMINAL		
	<ul style="list-style-type: none"> <li>● Key in ON position.</li> <li>● Engine OFF.</li> <li>● Measure voltage between battery positive post and voltage regulator 'A' terminal.</li> <li>● Is voltage difference more than 0.25 volt?</li> </ul>	Yes	▶ CHECK for high resistance in wiring between voltage regulator 'A' terminal and battery. SERVICE as required.
		No	▶ GO to A11.
A11	VOLTAGE DROP TEST — BATTERY POSITIVE VOLTAGE (B+) TERMINAL		
	<ul style="list-style-type: none"> <li>● Key in ON position.</li> <li>● Engine running.</li> <li>● Blower on HIGH, headlamps ON.</li> <li>● Measure voltage between generator Battery Positive Voltage (B+) output terminal and battery positive terminal.</li> <li>● Is difference less than 1.5 volts?</li> </ul>	Yes	▶ GO to A12.
		No	▶ CHECK for high resistance in wiring between generator Battery Positive Voltage (B+) output terminal and battery. SERVICE as required.
A12	'I' CIRCUIT CHECK		
	<ul style="list-style-type: none"> <li>● Key in ON position.</li> <li>● Blower on HIGH.</li> <li>● Engine running.</li> <li>● Disconnect voltage regulator connector.</li> <li>● Is charge indicator on?</li> </ul>	Yes	▶ SERVICE 'I' circuit for a short to ground.
		No	▶ GO to A13.
A13	'S' CIRCUIT CHECK		
	<ul style="list-style-type: none"> <li>● Reconnect voltage regulator connector.</li> <li>● Engine running.</li> <li>● Measure voltage at 'S' circuit at generator and at regulator.</li> </ul>	Voltage approximately 1/2 'A' circuit battery voltage at both locations	▶ GO to A14.
		Voltage approximately 1/2 'A' circuit battery voltage at generator but not at regulator	▶ SERVICE open in 'S' circuit wiring.
		No voltage at either location	▶ GO to A15.
A14	VOLTAGE OUTPUT CHECK		
	<ul style="list-style-type: none"> <li>● Engine running at 2000 rpm.</li> <li>● Measure battery voltage.</li> <li>● Is battery voltage above 16 volts?</li> </ul>	Yes	▶ CHECK generator for brush or rotor short to ground. CHECK regulator screws for tightness, or high resistance in 'A' circuit. If no concern found, REPLACE voltage regulator.
		No	▶ REPLACE voltage regulator.
A15	NO VOLTAGE CHECK		
	<ul style="list-style-type: none"> <li>● Ground 'F' screw on voltage regulator.</li> <li>● Check for voltage at 'S' terminal.</li> <li>● Is voltage approximately 1/2 battery voltage?</li> </ul>	Yes	▶ REPLACE regulator.
		No	▶ REPLACE generator assembly.

TJ3426D

## DIAGNOSIS AND TESTING (Continued)

## PINPOINT TEST B: CHARGING SYSTEM TEST — IAR GENERATOR

TEST STEP		RESULT	ACTION TO TAKE
<b>B1</b>	<b>PRELIMINARY CHECKS</b>		
	<ul style="list-style-type: none"> <li>● Preliminary Checks:               <ul style="list-style-type: none"> <li>— Fuse link</li> <li>— Battery terminals and cable clamps</li> <li>— Wiring and ground connections to generator, regulator and engine</li> <li>— Generator belt tension</li> </ul> </li> <li>● Are components OK?</li> </ul>	Yes No	GO to <b>B2</b> . SERVICE and/or REPLACE as necessary. GO to <b>B2</b> .
<b>B2</b>	<b>BASE VOLTAGE AND NO LOAD TEST</b>		
	<ul style="list-style-type: none"> <li>● Connect voltmeter to battery posts. Read battery voltage — this is base reading.</li> <li>● Start engine, run at 1500 rpm with no electrical load. Voltage should increase but not more than 3 volts.</li> <li>● Does voltage increase more than 3 volts?</li> </ul>	No No increase Yes	GO to <b>B3</b> . GO to <b>B5</b> . GO to <b>B12</b> .
<b>B3</b>	<b>LOAD TEST</b>		
	<ul style="list-style-type: none"> <li>● Increase engine speed to 2000 rpm.</li> <li>● Turn heater-A/C blower and headlamps on HIGH.</li> <li>● Is voltage a minimum of 0.5 volt over base voltage?</li> </ul>	Yes No	GO to <b>B4</b> . GO to <b>B5</b> .
<b>B4</b>	<b>BATTERY DRAIN TEST — KEY OFF</b>		
	<ul style="list-style-type: none"> <li>● Concern can still be battery drain. Turn OFF ignition, install test lamp in series with positive battery cable and check to isolate problem circuit.</li> <li>● Is there a battery drain?</li> </ul>	Yes No	CHECK vehicle circuits for drain. REFER to Section 14-01.
<b>B5</b>	<b>UNDER-VOLTAGE TEST</b>		
	<ul style="list-style-type: none"> <li>● Disconnect regulator.</li> <li>● Check resistance between regulator 'A' and 'F' terminals on regulator.</li> <li>● Is resistance more than 2.4 ohms?</li> </ul>	Yes No	GO to <b>B6</b> . CHECK generator for shorted field circuit and REPLACE generator assembly if required. If generator is OK, REPLACE regulator. GO to <b>B2</b> .
<b>B6</b>	<b>'A' TERMINAL VOLTAGE CHECK</b>		
	<ul style="list-style-type: none"> <li>● Reconnect regulator.</li> <li>● Measure 'A' terminal voltage.</li> <li>● Is there battery voltage?</li> </ul>	Yes No	GO to <b>B7</b> . SERVICE 'A' circuit wiring.
<b>B7</b>	<b>'F' TERMINAL VOLTAGE CHECK — IGNITION OFF</b>		
	<ul style="list-style-type: none"> <li>● Voltage regulator connected.</li> <li>● Key OFF.</li> <li>● Measure regulator 'F' terminal voltage with ignition off.</li> <li>● Is there battery voltage?</li> </ul>	Yes No	GO to <b>B8</b> . REPLACE generator assembly. GO to <b>B2</b> .
<b>B8</b>	<b>'F' TERMINAL VOLTAGE CHECK — IGNITION ON</b>		
	<ul style="list-style-type: none"> <li>● Turn ignition to RUN position (engine not running).</li> <li>● Measure regulator 'F' terminal voltage.</li> <li>● Is voltage more than 1.5 volts?</li> </ul>	Yes No	GO to <b>B9</b> . GO to <b>B10</b> .
<b>B9</b>	<b>'I' CIRCUIT TESTS</b>		
	<ul style="list-style-type: none"> <li>● Perform 'I' circuit tests.</li> <li>● Is circuit OK?</li> </ul>	Yes No	REPLACE regulator. GO to <b>B2</b> . SERVICE 'I' circuit wiring. GO to <b>B2</b> .
<b>B10</b>	<b>JUMPERED LOAD TEST</b>		
	<ul style="list-style-type: none"> <li>● Repeat Load Test measuring voltage to generator Battery Positive Voltage (B+) output terminal from battery negative clamp.</li> <li>● Does voltage rise 0.5 volt or more?</li> </ul>	Yes No	SERVICE generator to starter relay wiring. GO to <b>B2</b> . GO to <b>B11</b> .

## DIAGNOSIS AND TESTING (Continued)

## PINPOINT TEST B: CHARGING SYSTEM TEST — IAR GENERATOR (Continued)

TEST STEP		RESULT	ACTION TO TAKE
B11	LOAD TEST REPEAT — 'F' TERMINAL		
	<ul style="list-style-type: none"> <li>● Connect a jumper wire from generator rear housing to regulator 'F' terminal.</li> <li>● Repeat load test measuring voltage at Battery Positive Voltage (B+) output terminal.</li> <li>● Does voltage rise 0.5 volt or more?</li> </ul>	Yes	▶ REPLACE regulator. GO to B2.
		No	▶ REPLACE generator assembly. GO to B2.
B12	OVER-VOLTAGE TEST		
	<ul style="list-style-type: none"> <li>● Turn ignition to RUN position (engine not running).</li> <li>● Measure voltage at regulator 'A' terminal and starter solenoid.</li> <li>● Is voltage difference 0.5 volt or less?</li> </ul>	Yes	▶ GO to B13.
		No	▶ SERVICE A circuit wiring. GO to B2.
B13	REGULATOR GROUND CHECK		
	<ul style="list-style-type: none"> <li>● Check for loose regulator ground screws.</li> <li>● Is ground OK?</li> </ul>	Yes	▶ GO to B14.
		No	▶ SERVICE ground screws. GO to B2.
B14	ENGINE GROUND CHECK		
	<ul style="list-style-type: none"> <li>● Check for bad engine ground.</li> <li>● Is ground OK?</li> </ul>	Yes	▶ GO to B15.
		No	▶ SERVICE engine ground. GO to B2.
B15	GENERATOR GROUND CHECK		
	<ul style="list-style-type: none"> <li>● Check generator ground.</li> <li>● Is ground OK?</li> </ul>	Yes	▶ GO to B16.
		No	▶ SERVICE generator ground. GO to B2.
B16	REPEAT NO LOAD TEST		
	<ul style="list-style-type: none"> <li>● Start engine, run at 1500 rpm with no electrical load.</li> <li>● Voltage should increase but not more than 3 volts.</li> <li>● Does voltage increase more than 3 volts?</li> </ul>	No	▶ GO to B3.
		Yes	▶ GO to B17.
B17	'A' AND 'F' VOLTAGE CHECKS		
	<ul style="list-style-type: none"> <li>● Turn ignition OFF.</li> <li>● Measure voltage at regulator 'A' and 'F' terminals.</li> <li>● Terminal voltages should be the same as battery voltage.</li> <li>● Is there battery voltage at both terminals?</li> </ul>	Yes	▶ REPLACE regulator. GO to B2.
		No	▶ REPLACE generator assembly. GO to B2.

TJ3058E

## REMOVAL AND INSTALLATION

**WARNING: BATTERIES NORMALLY PRODUCE EXPLOSIVE GASES WHICH CAN CAUSE PERSONAL INJURY. THEREFORE, DO NOT ALLOW FLAMES, SPARKS OR LIGHTED SUBSTANCES TO COME NEAR THE BATTERY. WHEN CHARGING OR WORKING NEAR A BATTERY, ALWAYS SHIELD YOUR FACE AND PROTECT YOUR EYES. ALWAYS PROVIDE VENTILATION.**

**WHEN LIFTING A PLASTIC-CASED BATTERY, EXCESSIVE PRESSURE ON THE END WALLS COULD CAUSE ACID TO SPEW THROUGH THE VENT CAPS, RESULTING IN PERSONAL INJURY. LIFT WITH A BATTERY CARRIER OR WITH YOUR HANDS ON OPPOSITE CORNERS.**

**WARNING: KEEP BATTERIES OUT OF REACH OF CHILDREN. BATTERIES CONTAIN SULFURIC ACID. AVOID CONTACT WITH SKIN, EYES OR CLOTHING. ALSO, SHIELD YOUR EYES WHEN WORKING NEAR THE BATTERY TO PROTECT AGAINST POSSIBLE SPLASHING OF THE ACID SOLUTION. IN CASE OF ACID CONTACT WITH THE SKIN, EYES OR CLOTHING, FLUSH IMMEDIATELY WITH WATER FOR A MINIMUM OF FIFTEEN MINUTES. IF ACID IS SWALLOWED, DRINK LARGE QUANTITIES OF MILK OR WATER, FOLLOWED BY MILK OF MAGNESIA, A BEATEN EGG, OR VEGETABLE OIL. CALL A PHYSICIAN IMMEDIATELY.**

**REMOVAL AND INSTALLATION (Continued)**

**Generator**

**Removal**

1. Disconnect battery ground cable.
2. Disconnect the wire harness attachments to the integral generator / regulator assembly.
3. Loosen the generator pivot bolt. Remove the adjustment arm bolt from the generator.
4. Disengage the accessory drive belt from the generator pulley.
5. Remove the generator pivot bolt and generator / regulator assembly.

3.0L/3.8L

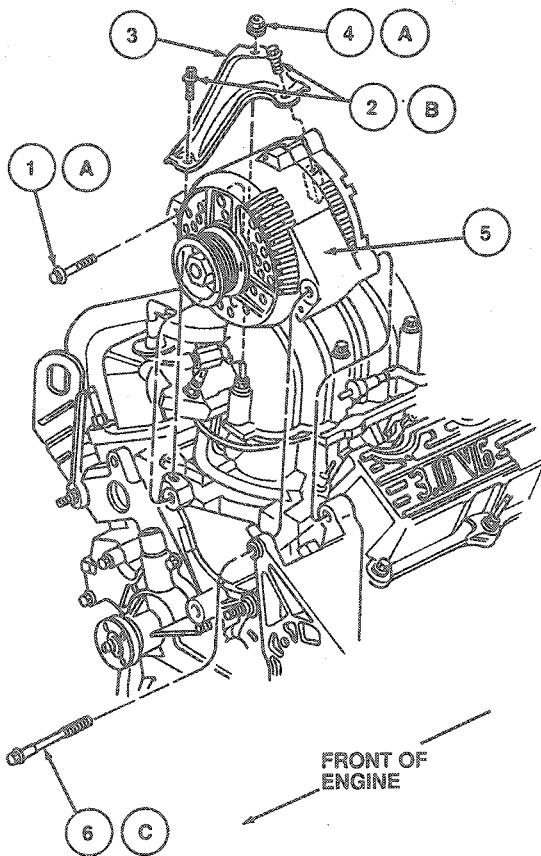

J4452-A

Item	Part Number	Description
1A	N807274-S309B	Adjusting Arm Bolt
2B	N605892-S8	Bolt (2 Req'd)
3	10B315	Alternator Brace
4A	N621939-S53B	Nut and Washer
5	10300	Alternator
6C	N807241-S36B	Pivot Bolt
A		Tighten to 20-30 N·m (15-22 Lb-Ft)
B		Tighten to 8.5-11N·m (7-8 Lb-Ft)

(Continued)

Item	Part Number	Description
C		Tighten to 40-55 N·m (30-41 Lb-Ft)

TJ4452A

**Installation**

1. Position the integral generator / regulator assembly on the engine.
2. Install the generator pivot and adjustment arm bolts, but do not tighten the bolts until the belt is tensioned.
3. Install the accessory drive belt over the generator pulley.
4. Tighten the adjustment arm bolt to 20-30 N·m (15-22 lb-ft) and pivot bolt to 40-55 N·m (30-41 lb-ft).
5. Connect the wiring harness to the generator / regulator assembly.
6. Connect battery ground cable.

**Regulator**

**Removal**

1. Remove the four screws (T20 TORX®-type head) attaching the regulator to the generator rear housing. Remove the regulator, with brush holder attached, from the generator.

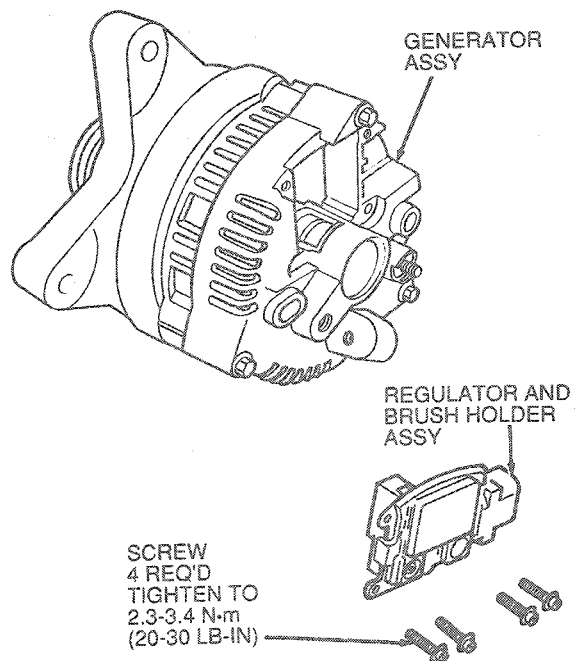

J4486-A

2. Hold the regulator in one hand and pry off the cap covering the 'A' screw head with a screwdriver.

## REMOVAL AND INSTALLATION (Continued)

- Remove two screws (T20 TORX® type head) attaching the regulator to the brush holder. Separate the regulator from brush holder assembly.

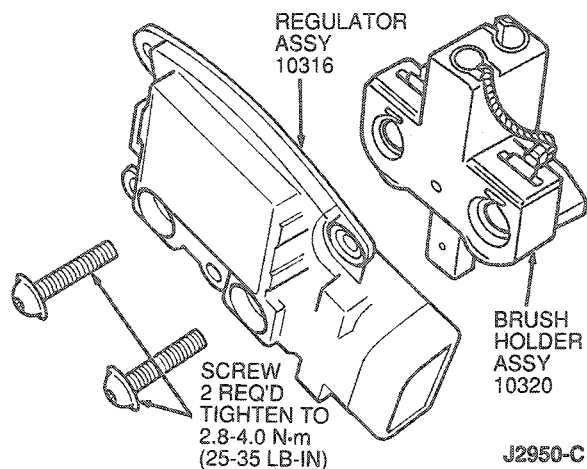

## Installation

- Replace brush holder to regulator and install attaching screws.
- Replace cap on the head of the 'A' terminal screw.
- Depress the brushes into the holder and hold the brushes in position by inserting a standard size paper clip (or equivalent) through both the location hole in the regulator and through the holes in the brushes.
- Install the regulator and brush holder assembly to the generator assembly with attaching screws.

NOTE: Remove paper clip (or equivalent) from the regulator.

## DISASSEMBLY AND ASSEMBLY

NOTE: The regulator, brush holder, fan and pulley are serviceable. If the generator assembly needs further service, it must be replaced as an assembly.

## SPECIFICATIONS

## TORQUE SPECIFICATIONS

Description	N·m	Lb·Ft
Regulator Grounding Screws	1.76-2.8	16-24 (Lb-In)
Adjustment Arm Bolt	20-30	15-22
Pivot Bolt	40-55	30-41
Adjusting Brace Bolts	8.5-11	7-8
Generator Brace Nut	20-30	15-22

## SPECIAL SERVICE TOOLS

## ROTUNDA EQUIPMENT

Model	Description
007-00001	Digital Volt Ohmmeter
078-00005	Starting and Charging System Tester