

DIAGNOSIS AND TESTING (Continued)

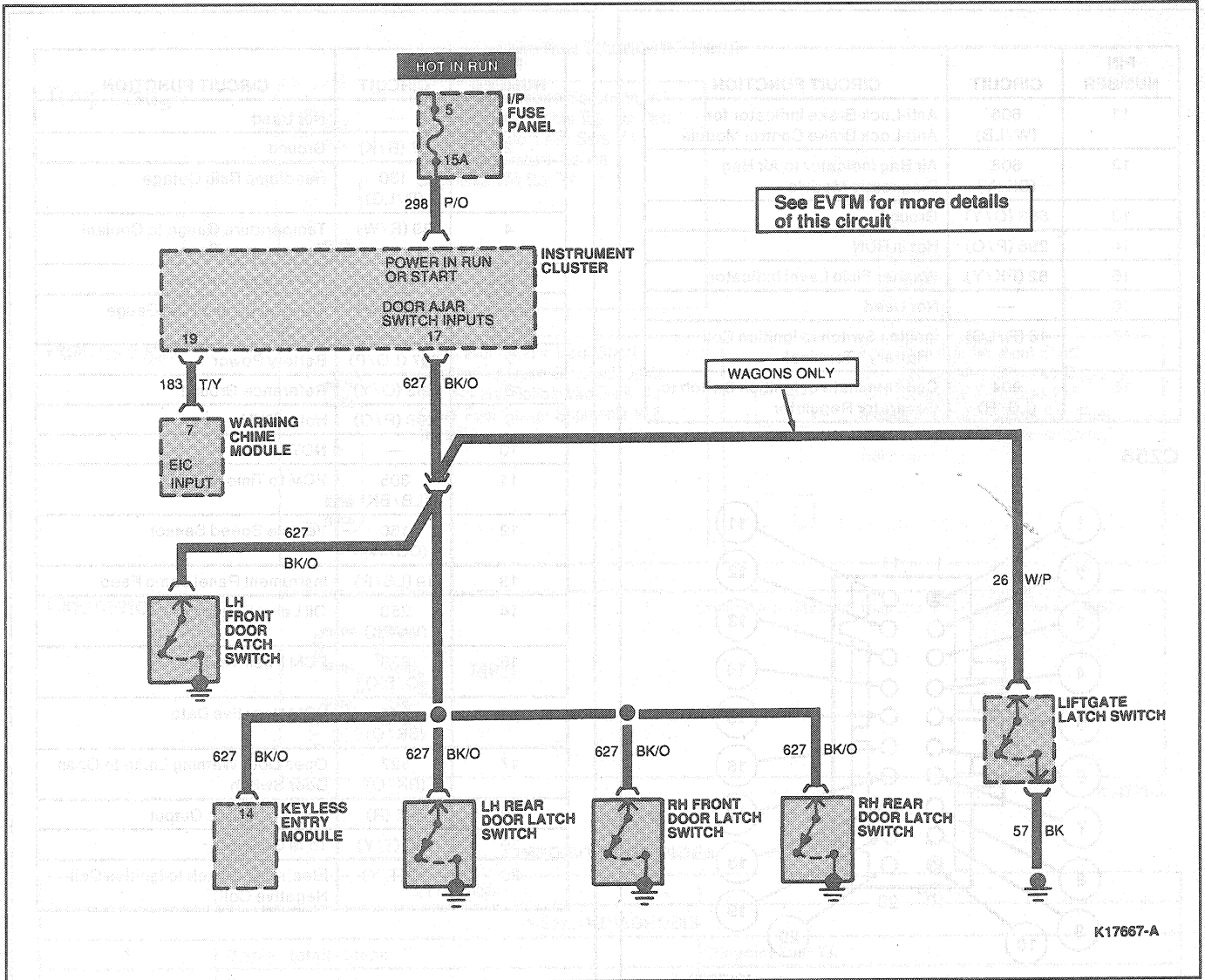

Wiring Harness Connectors
C255

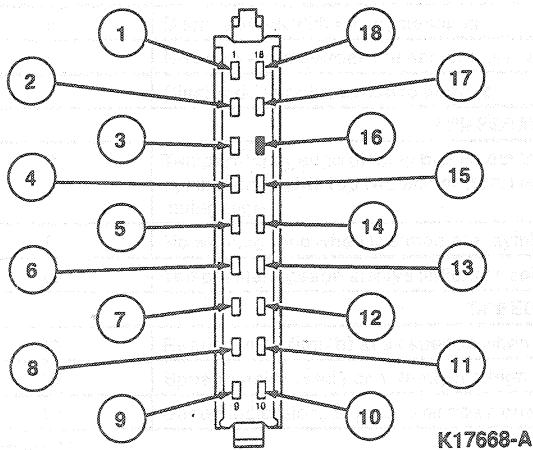

PIN NUMBER	CIRCUIT	CIRCUIT FUNCTION
1	31 (W/R)	Oil Pressure Indicator to Oil Pressure Sending Unit
2	640 (R/Y)	Warning Lamps Feed-Hot in RUN or START
3	977 (P/W)	Brake Warning Switch to Indicator Lamp
4	932 (GY/W)	Hi Beam Indicator
5	3 (LG/W)	LH Turn Signal Lamps
6	434 (LB/BK)	Instrument Panel Lamp Feed
7	57 (BK)	Ground
8	2 (W/LB)	RH Turn Signal Lamps
9	450 (DG/LG)	Safety Belt Warning Indicator Lamp Feed
10	201 (T/R)	PCM to Check Engine Lamp

(Continued)