

# SECTION 13-06 Horn

SUBJECT	PAGE	SUBJECT	PAGE
<b>DESCRIPTION AND OPERATION</b>		<b>REMOVAL AND INSTALLATION</b>	
Horn System .....	13-06-1	Horn .....	13-06-1
<b>DIAGNOSIS AND TESTING</b>		Horn Button Switch .....	13-06-2
Backup Power Supply .....	13-06-1	<b>SPECIFICATIONS</b> .....	13-06-2
Circuit Check .....	13-06-1	<b>VEHICLE APPLICATION</b> .....	13-06-1

## VEHICLE APPLICATION

Taurus / Sable and Taurus SHO.

## DESCRIPTION AND OPERATION

### Horn System

The standard high and low pitch horns are mounted to the LH frame rail on a common bracket. The horn switch closes the circuit to the horn through a relay.

## DIAGNOSIS AND TESTING

### Circuit Check

Verify that the ground at the horn is good by checking connection for corrosion. Also verify that the retaining screw is tight and horns are not touching surrounding sheet metal or other components.

Attach a wire from battery positive (+) terminal to horn. If the horn sounds normally, check the wiring between horn and horn switch. If the horn does not sound, replace horn.

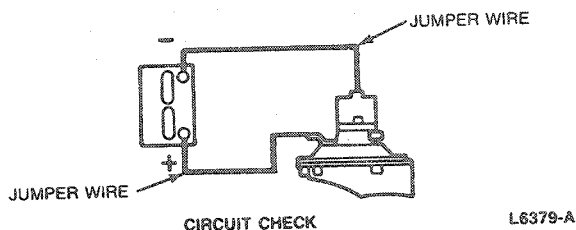

L6379-A

### Backup Power Supply

**WARNING: THE BACKUP POWER SUPPLY MUST BE DISCONNECTED BEFORE ANY AIR BAG COMPONENT SERVICE IS PERFORMED.**

A backup power supply is included in the system to provide air bag deployment if the battery or battery cables are damaged in an accident before the crash sensors close. The power supply is a capacitor that will discharge approximately 15 minutes after the battery is disconnected. It is located in the RH instrument panel above the glove compartment.

## REMOVAL AND INSTALLATION

### Horn

#### Removal and Installation

1. Disconnect horn wire from terminal.

2. Remove retaining screw.

3. Remove horn.

4. To install, reverse Removal procedure. Tighten retaining screw to 8-12 N·m (6-8 lb-ft).

**REMOVAL AND INSTALLATION (Continued)**

**Taurus / Sable**

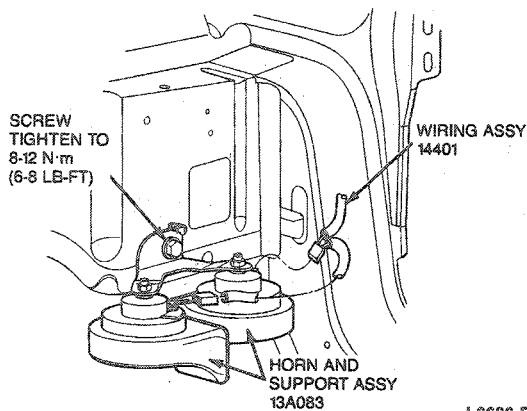

L6686-B

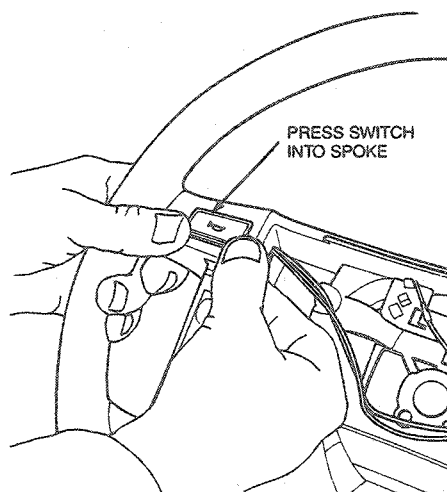

K14574-A

3. Connect electrical connectors.
4. Position air bag module on steering wheel and install four nut and washer assemblies. Tighten to 4-5.6 N·m (35-53 lb-in).
5. Connect backup power supply.
6. Connect battery ground cable.

**Horn Button Switch**

**Removal**

1. Disconnect battery ground cable.
2. Disconnect backup power supply.
3. Remove air bag module.
4. With a screwdriver, carefully pry horn button switch from steering wheel spoke.

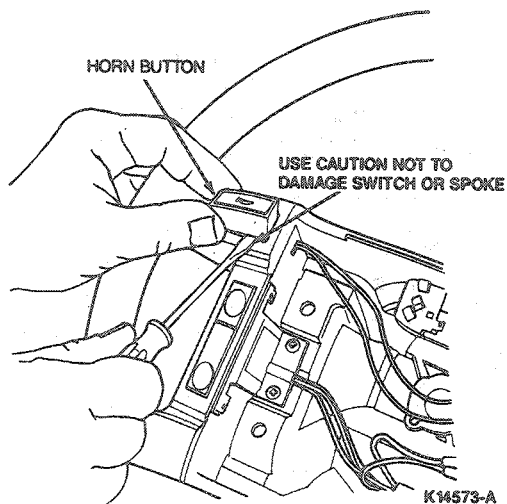

K14573-A

5. Disconnect electrical connectors, remove horn button switch and wires.

**Installation**

1. Insert horn button switch wires through opening in steering spokes.
2. Press horn button switch into steering wheel spoke.

NUT AND WASHER ASSY N621903-S2  
4 REQ'D  
TIGHTEN TO 4-5.6 N·m (35-50 LB-IN)

STEERING WHEEL AND COLUMN

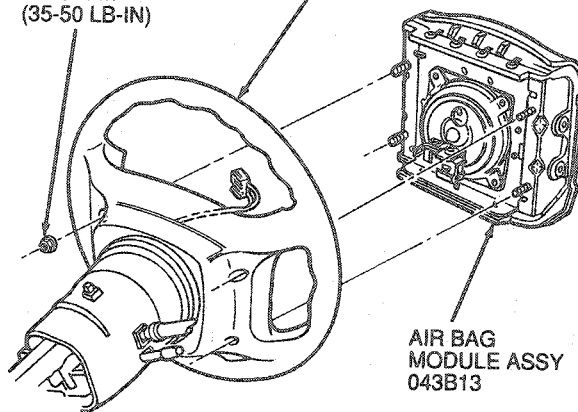

R6333-C

**SPECIFICATIONS**

**TORQUE SPECIFICATIONS**

Description	N·m	Lb-Ft
Air Bag Module Retaining Nuts	4-5.6	35-53 (Lb-In)
Horn Retaining Screw	8-12	6-8

# SECTION 13-07 Clock

SUBJECT	PAGE	SUBJECT	PAGE
DESCRIPTION AND OPERATION		REMOVAL AND INSTALLATION	
Setting Time .....	13-07-1	Clock.....	13-07-3
DIAGNOSIS AND TESTING.....	13-07-1	VEHICLE APPLICATION .....	13-07-1

## VEHICLE APPLICATION

Taurus / Sable.

## DESCRIPTION AND OPERATION

The electronic digital clock displays time in a 12-hour format. Display dims when headlamps are on.

### Setting Time

1. Press and hold H button until desired hour is displayed.
2. Press and hold M button until desired minute is displayed.

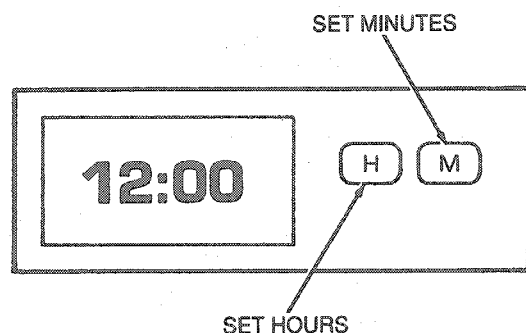

K17224-A

## DIAGNOSIS AND TESTING

The clock is serviced as an assembly. An inoperable clock should be removed and returned to a service center (shown on part number label on clock case) to be serviced. The clock will be replaced with a functioning clock.

**NOTE:** Display illuminates with the ignition switch in the ACC or RUN position.

### Clock Connector

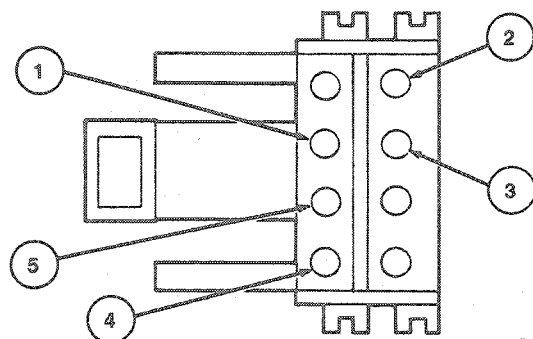

K17225-A

**DIAGNOSIS AND TESTING (Continued)**

ITEM NO.	CIRCUIT	DESCRIPTION
1	57	Ground
2	14	Headlamp

(Continued)

ITEM NO.	CIRCUIT	DESCRIPTION
3	54	Dome Lamp
4	19	Rheostat
5	296	Ignition

TK17225A

**PINPOINT TEST A: ELECTRONIC DIGITAL CLOCK FUNCTIONAL TEST**

TEST STEP		RESULT	ACTION TO TAKE
A1	<b>CLOCK FUNCTION</b> ● Turn ignition to RUN or ACC. ● Does display come on?	Yes	▶ GO to A2.
		No	▶ GO to B1.
A2	<b>DIMMING FUNCTION</b> ● Turn headlamps ON. ● Does display dim?	Yes	▶ GO to A3.
		No	▶ GO to B4.
A3	<b>SET TIME—HOURS</b> ● Depress H button and hold. ● Do hours advance?	Yes	▶ GO to A4.
		No	▶ REPLACE unit and VERIFY. GO to A1, Functional Test.
A4	<b>SET TIME—MINUTES</b> ● Depress M button and hold. ● Do minutes advance?	Yes	▶ Clock OK.
		No	▶ REPLACE unit and VERIFY. GO to A1, Functional Test.

TK16948B

**PINPOINT TEST B: WIRING HARNESS CHECK SUBROUTINE B**

TEST STEP		RESULT	ACTION TO TAKE
B1	<b>POWER TO CLOCK—CHECK FUSE</b> ● Open vehicle door. ● Does dome lamp light?	Yes	▶ GO to B2.
		No	▶ CHECK fuse. VERIFY dome lamp works. GO to A1.
B2	<b>POWER TO CLOCK HARNESS CHECK</b> ● Put non-powered test lamp between vehicle ground and Circuit 54 on back of male clock connector. ● Does test lamp light?	Yes	▶ GO to B3.
		No	▶ Concern in Circuit 54, SERVICE and VERIFY clock operation. GO to A1.

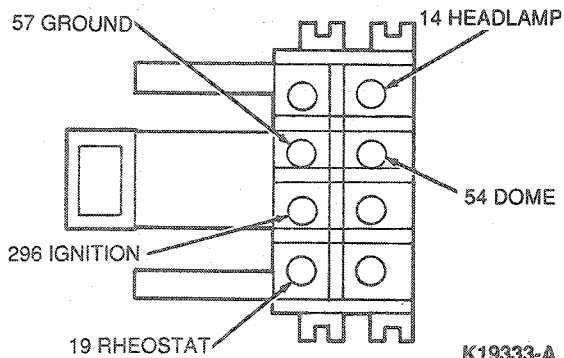

K19333-A

## DIAGNOSIS AND TESTING (Continued)

## PINPOINT TEST B: WIRING HARNESS CHECK SUBROUTINE B (Continued)

TEST STEP		RESULT	ACTION TO TAKE
<b>B3</b>	<b>POWER TO GROUND CIRCUIT CHECK</b> <ul style="list-style-type: none"> <li>● Put test lamp between Circuit 57 (GND) and 54.</li> <li>● Does test lamp light?</li> </ul>	Yes	▶ REPLACE and VERIFY clock operation. GO to A1.
		No	▶ Concern in Circuit 57. SERVICE and VERIFY clock operation. GO to A1.
<b>B4</b>	<b>HEADLAMP SWITCH TO CLOCK HARNESS CHECK</b> <ul style="list-style-type: none"> <li>● Put test lamp between Circuit 57 and Circuit 14 on back of clock connector. Turn headlamps ON.</li> <li>● Does test lamp light?</li> </ul>	Yes	▶ GO to B5.
		No	▶ Concern in Circuit 14. SERVICE and VERIFY clock operation. GO to A1.
<b>B5</b>	<b>CHECK POWER TO IGNITION</b> <ul style="list-style-type: none"> <li>● Connect test lamp between Circuit 57 and Circuit 296.</li> <li>● Turn ignition to ACC.</li> <li>● Does test lamp light?</li> </ul>	Yes	▶ REPLACE and VERIFY clock operation.
		No	▶ SERVICE open in Circuit 296, and VERIFY clock operation. GO to A1.

TK19287A

## REMOVAL AND INSTALLATION

## Clock

## Removal and Installation

1. Remove instrument panel applique.
2. Disconnect clock electrical connector.

3. Remove two screws retaining clock into panel applique (one on each clock mounting tab).
4. Remove clock from applique.
5. To install, reverse Removal procedure.

# SECTION 13-09 Gauges, Warning Devices, Miscellaneous — Electronic

SUBJECT	PAGE	SUBJECT	PAGE
<b>DESCRIPTION AND OPERATION</b>		<b>REMOVAL AND INSTALLATION</b>	
Lamp-Out Warning System.....	13-09-1	Lamp-Out Warning Module .....	13-09-17
Low Oil Level Warning System.....	13-09-2	Low Oil Level Sensor.....	13-09-18
Warning Chimes.....	13-09-1	Warning Chime .....	13-09-17
<b>DIAGNOSIS AND TESTING</b>		<b>SPECIAL SERVICE TOOLS</b> .....	13-09-19
Lamp-Out Warning System.....	13-09-8	<b>SPECIFICATIONS</b> .....	13-09-19
Low Oil Level Sensor Test .....	13-09-6	<b>VEHICLE APPLICATION</b> .....	13-09-1
Low Oil Level Warning System Check .....	13-09-5		

## VEHICLE APPLICATION

Taurus/Sable.

## DESCRIPTION AND OPERATION

### Warning Chimes

#### Safety Belt Warning

When the ignition switch is turned to RUN or START, power is supplied through Circuit 640 (R/Y) to the warning chime module. The module then supplies power through Circuit 450 (DG/LG) to illuminate the FASTEN BELTS indicator for six seconds, whether or not the driver's safety belt is fastened. If the driver's safety belt is not fastened during this time, the safety belt buckle switch remains closed, supplying ground through Circuit 85 (BR/LB) to the warning chime module and causing it to sound for six seconds.

#### Key-In-Ignition Warning

The warning chime sounds when the driver's door is opened, with the key in the ignition switch, and continues to sound until the key is removed or the door is closed. When the key is in ignition, the key-in-ignition switch is closed and ground is supplied through Circuit 158 (BK/PK) to the warning chime module. When the driver's door is open, the driver's door courtesy lamp switch closes and power is supplied through Circuit 159 (R/PK) to the module.

### Headlamp Switch On Warning

The warning chime sounds when the driver's door is opened while the main headlamp switch is on, and continues to sound until the switch is turned off or the door is closed.

When the main headlamp switch is on, power is supplied through Circuit 257 (W/R) to the warning chime module. When the driver's door is open, the driver's door courtesy lamp switch is closed and power is supplied through Circuit 159 (R/PK) to the module.

### Electronic Instrument Cluster Beep Tone

On vehicles with an electronic instrument cluster only. When a cluster button is pressed, the cluster momentarily grounds Circuit 183 (T/Y) to the warning chime module, causing it to emit a momentary beep tone as acknowledgement.

Whenever selected visual warning messages are displayed on the electronic instrument cluster, the cluster grounds Circuit 183 (T/Y) to the warning chime module for one second. This causes it to emit a one second beep tone to attract attention to the electronic cluster display.

### Lamp-Out Warning System

A lamp outage is sensed by measuring the change in voltage drop across a special section of the wiring harness.

The unique wiring harnesses associated with the lamp-out warning system use special resistance wire for proper system operation.

**CAUTION:** Do not alter lengths of these wires, unless otherwise directed. Do not hook up additional lamps (i.e. trailer tow lamps). Do not replace bulbs with any type different from original equipment. Doing so may result in a false warning or no warning.

## DESCRIPTION AND OPERATION (Continued)

The Lamp-Out Warning System consists of a lamp-out warning module, a unique wiring harness and one warning indicator in the conventional instrument cluster, or two warning indicators in the digital instrument cluster. The lamp-out warning system monitors three functions:

- Low-beam headlamps
- Rear parking lamps
- Brakelamps

The system operates when the ignition switch is in the ACC or RUN position.

### Digital Cluster:

**REAR LAMP OUT:** Indicates a brakelamp burn out when the brake pedal is pressed. Rear Lamp Out will also indicate a rear parking lamp burnout when the light switch is turned to either the parking lamp or headlamp position.

**HEADLAMP OUT:** Indicates a low-beam headlamp burnout when the light switch is turned to the headlamp position.

### Analog Cluster:

**LAMP OUT:** Combines the functions of REAR LAMP OUT and HEADLAMP OUT.

## Low Oil Level Warning System

This system consists of a float-type sensor mounted to the side of the engine oil pan, an electronic control module (an electronic relay) and an instrument panel warning indicator.

The warning indicator should come on during engine starting as a bulb prove-out. When the ignition switch is turned to the RUN or START position, the control module determines whether the sensor is grounded (oil low) or ungrounded (oil not low). If the oil level is adequate, the light will go out in RUN. If oil level is approximately 1.4L (1.5 qt) low or lower, the relay keeps the warning indicator on. The indicator remains on until the oil level is adequate or the ignition switch is turned to the OFF position. After the ignition switch is turned to the OFF position, the module will not reset for approximately five minutes. The delay allows time for oil drainback before another reading is allowed to occur. If the engine is restarted during this delay period, the indicator will stay off, unless it was previously on and sensor is still grounded.

### Low Oil Level Warning Indicator

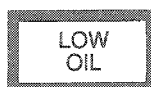

K19334-A

## Sensor Installation

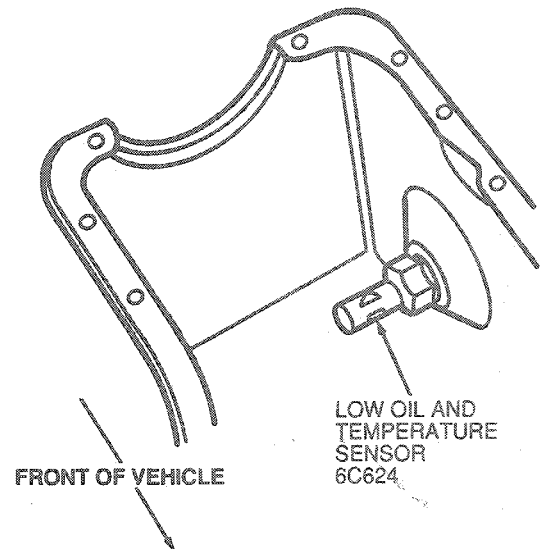

K16716-B

## Low Coolant Level Indicator

A coolant level sensor is mounted on the recovery reservoir and is used to illuminate the CHECK COOLANT indicator located in the cluster. When the ignition is turned to RUN position, the indicator will prove out momentarily and turn off after the engine is started, indicating adequate coolant fill. The CHECK COOLANT indicator will turn on when the coolant level drops below the FULL COLD mark located on the side of the recovery reservoir. When indicating a low coolant condition, the indicator will illuminate and remain on until the coolant is filled to the FULL HOT mark and vehicle ignition is turned off and then cycled back on.

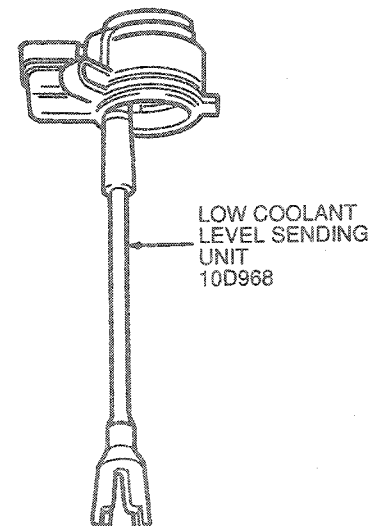

K17131-B

**DIAGNOSIS AND TESTING**

Check system fuse before proceeding.

- Equipment: 12-volt test lamp or ohmmeter
- When necessary to trace and / or service the various circuits, refer to the vehicle wiring diagrams and diagnostic chart.

**Warning Chime System Diagram**

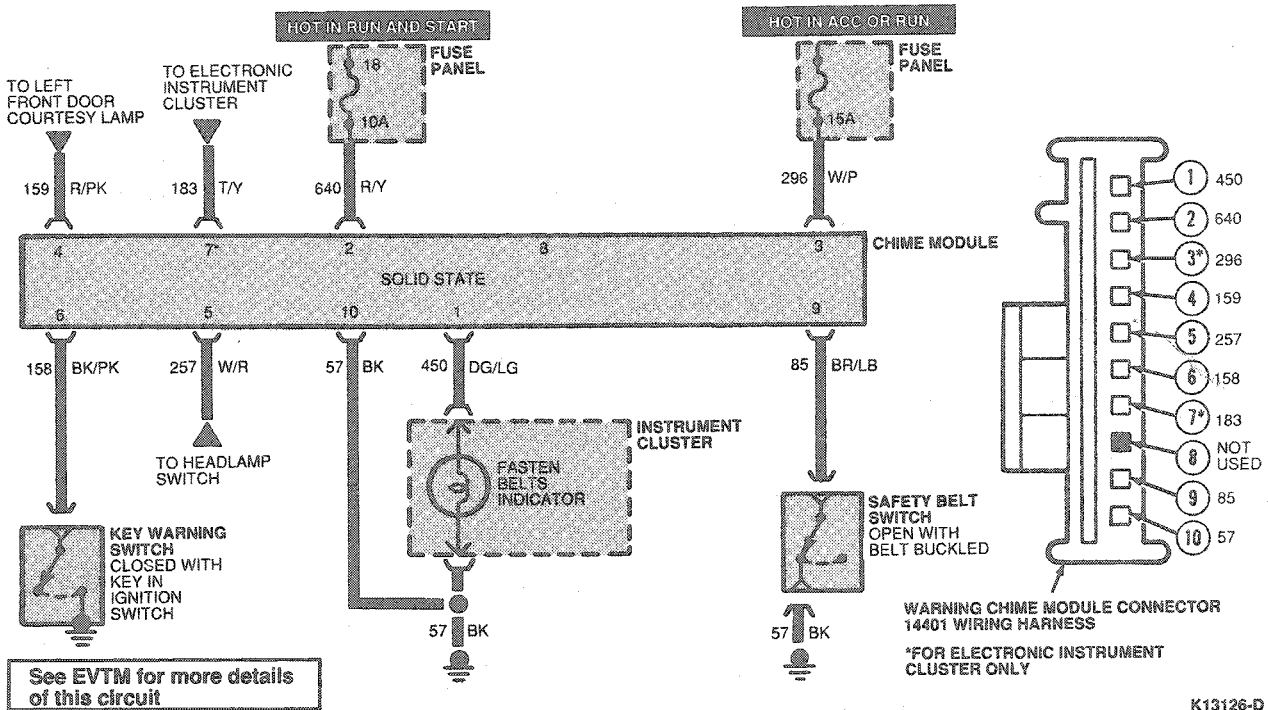

**NOTE:** The following step-by-step diagnosis must be performed to obtain reliable results. If a specific failure condition is known, refer to the Electrical and Vacuum Troubleshooting manual to quickly determine root cause and corrective action.

**ELECTRONIC WARNING CHIME DIAGNOSIS**

Terminal No.	Circuit	Wire Color	Function
1	450	DG/LG	Warning chime module to safety belt warning indicator
2	640	R/Y	Ignition (RUN or START) to warning chime module
3	296	W/P	Ignition (RUN or ACC) to warning chime module for electronic cluster only
4	159	R/PK	Dirver door courtesy switch to warning chime module
5	257	R/W	Headlamp switch to warning chime module
6	158	BK/PK	Key warning switch to warning chime module
7	183	T/Y	Tripminder to warning chime module for electronic cluster only
9	85	BR/LB	Safety belt switch to warning chime module
10	57	BK	Ground to warning chime module

TK17147B



## DIAGNOSIS AND TESTING (Continued)

**PINPOINT TEST A  
ELECTRONIC WARNING CHIME DIAGNOSIS**

TEST STEP		RESULT	ACTION TO TAKE
<b>A1</b>	<b>CHECK WARNING CHIME SYSTEM FUSE</b>		
	<ul style="list-style-type: none"> <li>● If warning chime module is properly connected, check the warning chime system fuse.</li> <li>● Is fuse OK?</li> </ul>	Yes No	GO to A2. REPLACE fuse.
<b>A2</b>	<b>CHECK FOR VOLTAGE AT CIRCUIT 640 (R/Y)</b>		
	<ul style="list-style-type: none"> <li>● Disconnect warning chime module.</li> <li>● Connect a 12-volt test lamp between Circuit 640 (R/Y) in warning chime connector and ground.</li> <li>● Turn ignition switch to RUN.</li> <li>● Does test lamp light?</li> </ul>	Yes No	GO to A3. CHECK Circuit 640 (R/Y) back to ignition switch. SERVICE as required. REPEAT A2.
<b>A3</b>	<b>CHECK FOR GROUND AT CIRCUIT 57 (BK)</b>		
	<ul style="list-style-type: none"> <li>● Connect a 12-volt test lamp between Circuit 640 (R/Y) and 57 (BK) in warning chime connector.</li> <li>● Turn ignition switch to RUN.</li> <li>● Does test lamp light?</li> </ul>	Yes No	GO to A4. CHECK Circuit 57 (BK) back to body ground. SERVICE as required. REPEAT A3.
<b>A4</b>	<b>CHECK CKT 450 (DG/LG) AND SAFETY BELT WARNING LAMP BULB</b>		
	<ul style="list-style-type: none"> <li>● Connect jumper between Circuit 450 (DG/LG) and Circuit 640 (R/Y) in warning chime module connector.</li> <li>● Turn ignition switch to RUN.</li> <li>● Does safety belt warning indicator light?</li> </ul>	Yes No	GO to A5. CHECK Circuit 450 (DG/LG) back to safety belt warning indicator bulb. CHECK bulb. SERVICE as required. REPEAT A4.
<b>A5</b>	<b>CHECK FOR GROUND AT CIRCUIT 85 (BR/LB)</b>		
	<ul style="list-style-type: none"> <li>● Unbuckle driver's side safety belt.</li> <li>● Connect a 12-volt test lamp between Circuit 85 (BR/LB) and Circuit 640 (R/Y) in warning chime connector.</li> <li>● Turn ignition switch to RUN.</li> <li>● Does test lamp light?</li> </ul>	Yes No	GO to A6. CHECK Circuit 85 (BR/LB) back to safety belt switch. SERVICE as required. REPEAT A5.
<b>A6</b>	<b>CHECK FOR GROUND AT CIRCUIT 158 (BK/PK)</b>		
	<ul style="list-style-type: none"> <li>● Insert key in ignition.</li> <li>● Connect a 12-volt test lamp between Circuit 158 (BK/PK) and Circuit 640 (R/Y) in warning chime connector.</li> <li>● Turn ignition switch to RUN.</li> <li>● Does test lamp light?</li> </ul>	Yes No	GO to A7. CHECK Circuit 158 (BK/PK) back to ignition key cylinder switch. SERVICE as required. REPEAT A6.
<b>A7</b>	<b>CHECK FOR VOLTAGE AT CIRCUIT 159 (R/PK)</b>		
	<ul style="list-style-type: none"> <li>● Connect a 12-volt test lamp between Circuit 159 (R/PK) in warning chime connector and a known good ground.</li> <li>● Open driver's door.</li> <li>● Does test lamp light?</li> </ul>	Yes No	GO to A8. CHECK Circuit 159 (R/PK) back to courtesy lamp switch. SERVICE as required. REPEAT A7.
<b>A8</b>	<b>CHECK FOR VOLTAGE AT CIRCUIT 257 (W/R)</b>		
	<ul style="list-style-type: none"> <li>● Connect a 12-volt test lamp between Circuit 257 (W/R) and a known good ground.</li> <li>● Pull headlamp switch to the ON position.</li> <li>● Does test lamp light?</li> </ul>	Yes No	GO to A9. CHECK Circuit 257 (W/R) back to headlamp switch. SERVICE as required. REPEAT A8.
<b>A9</b>	<b>CHECK FOR VOLTAGE AT CIRCUIT 296 (W/P)</b>		
	<ul style="list-style-type: none"> <li>● Connect a 12-volt test lamp between Circuit 296 (W/P) in warning chime connector and ground.</li> <li>● Turn ignition switch to the ACC position.</li> <li>● Does test lamp light?</li> </ul>	Yes No	GO to A10. CHECK Circuit 296 (W/P) back to ignition switch. SERVICE as required. REPEAT A9.

**DIAGNOSIS AND TESTING (Continued)**

**PINPOINT TEST A  
ELECTRONIC WARNING CHIME DIAGNOSIS (Continued)**

TEST STEP	RESULT	ACTION TO TAKE
<b>A10</b> CHECK FOR GROUND AT CIRCUIT 183 (T/Y) <ul style="list-style-type: none"> <li>● Connect a 12-volt test lamp between Circuit 183 (T/Y) and Circuit 296 (W/P) of warning chime connector.</li> <li>● Turn ignition switch to RUN position and press a button on the electronic instrument cluster.</li> <li>● Does test lamp light momentarily?</li> </ul>	Yes No	GO to A11. REFER to electronic instrument cluster diagnostics, Section 13-01. SERVICE as required. REPEAT A10.
<b>A11</b> CHECK WARNING CHIME MODULE OPERATION <ul style="list-style-type: none"> <li>● Connect warning chime module.</li> <li>● Check for proper operation of:                             <ul style="list-style-type: none"> <li>— Safety belt warning.</li> <li>— Key-in-ignition warning.</li> <li>— Headlamp switch on warning.</li> <li>— Audible beep.</li> </ul> </li> </ul>	All warnings operate properly One, two, or three warnings inoperative All warnings not operating	System operating properly. CHECK back through appropriate circuit(s). SERVICE as necessary. REPEAT A11. REPLACE warning chime module. REPEAT A11.

TK17165A

**Low Oil Level Warning System Check**

With oil at FULL mark on dipstick and the engine oil warm to ensure that the oil drains properly from the oil sensor, turn ignition switch to the RUN position and start engine. Warning indicator should come on briefly in START for bulb prove-out, then go out. Turn engine off. Drain 1.9L (2 qt) of oil from engine. Wait for five minutes, then restart engine. Warning indicator should come on and stay on.

If indicator does not come on, check the following:

- Indicator
- Fuse
- Low oil level relay
- Low oil level sensor

Refer to diagnosis charts for complete testing procedures.

**Electrical Schematic — Low Oil Level Relay**

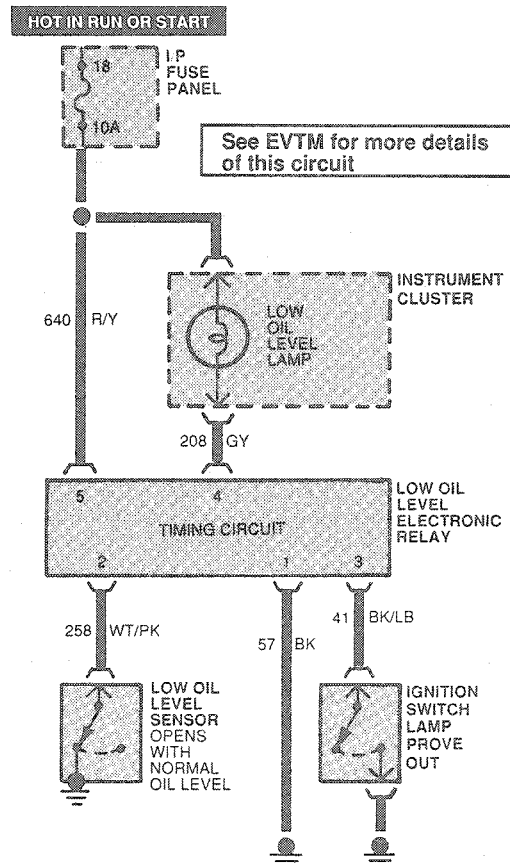

K7920-E

**DIAGNOSIS AND TESTING (Continued)**

**Low Oil Level Sensor Test**

**Tools Required:**

- Rotunda Digital Volt-Ohmmeter 007-00001

Connect positive lead of a Rotunda Digital Volt-Ohmmeter 007-00001 or equivalent to sensor terminal and negative lead to sensor housing. With sensor submerged in oil (engine full), meter should read "open." Resistance should be greater than 100,000 ohms. With sensor out of oil (oil drained), resistance should be less than 1000 ohms.

**NOTE:** Sensor must be horizontal when this test is conducted.

It is best to conduct test with sensor in pan with hot oil to ensure that oil properly drains from sensor. If removed from pan, sensor must first be submerged in warm oil to ensure proper positioning of the float before testing. The sensor must be held horizontally during bench testing to ensure that the float remains correctly positioned.

**NOTE:** The module is located on the instrument panel shake brace.

**Pinpoint Test Index**

SYMPTOM	PINPOINT TEST
Low Oil Level Indicator Stays On After Starting Engine-Oil Not Low	A
Low Oil Level Indicator Does Not Stay On When Low On Oil	B
Low Oil Level Indicator Blinks Intermittently While Driving	C
Low Coolant Level Indicator Inoperative	D

**NOTE:** Ignition should be turned OFF for five minutes between checks to be sure that the electronic relay has "reset".

**PINPOINT TEST A: LOW OIL LEVEL INDICATOR STAYS ON AFTER STARTING ENGINE — OIL NOT LOW**

TEST STEP	RESULT	ACTION TO TAKE
<b>A1</b> CHECK OIL LEVEL AND RELAY GROUND		
<ul style="list-style-type: none"> <li>● Verify oil level is full then check electronic relay ground by disconnecting wire Circuit 258 (W/PK) from sensor and restart engine.</li> <li>● Does indicator turn off?</li> </ul>	Yes	CHECK sensor resistance. If less than 1000 K ohms, REPLACE sensor. If greater than 1000 K ohms—REPLACE electronic relay.
	No	GO to A2.
<b>A2</b> CHECK OIL SENSOR CIRCUIT		
<ul style="list-style-type: none"> <li>● Check wiring circuit between electronic relay and terminal 4 of electronic relay.</li> <li>● Is wire OK?</li> </ul>	Yes	REPLACE electronic relay.
	No	SERVICE wiring.

TK17142B

**PINPOINT TEST B: LOW OIL LEVEL INDICATOR DOES NOT STAY ON WHEN LOW ON OIL 1.9 LITERS (TWO QUARTS)**

TEST STEP	RESULT	ACTION TO TAKE
<b>B1</b> CHECK ELECTRONIC RELAY		
<ul style="list-style-type: none"> <li>● Check electronic relay by disconnecting wire Circuit 258 (W/PK) from terminal 4. Wait approximately five minutes. Then short terminal to ground. Start engine.</li> <li>● Does indicator stay on?</li> </ul>	Yes	RECONNECT wire. GO to B2.
	No	REPLACE electronic relay.
<b>B2</b> CHECK SENSOR RESISTANCE		
<ul style="list-style-type: none"> <li>● Check sensor resistance between sensor terminal and ground.</li> <li>● Is resistance greater than 1000K ohms?</li> </ul>	Yes	REPLACE sensor.
	No	CHECK wiring or connector to sensor for open circuit.

TK17143B

DIAGNOSIS AND TESTING (Continued)

**PINPOINT TEST C: LOW OIL LEVEL INDICATOR BLINKS INTERMITTENTLY WHILE DRIVING**

TEST STEP	RESULT	ACTION TO TAKE
<b>C1</b> CHECK CONNECTIONS		
<ul style="list-style-type: none"> <li>Check for loose connections to relay or bulb.</li> <li>Are connections OK?</li> </ul>	No	SERVICE connections.
	Yes	REPLACE electronic relay.

TK7921F

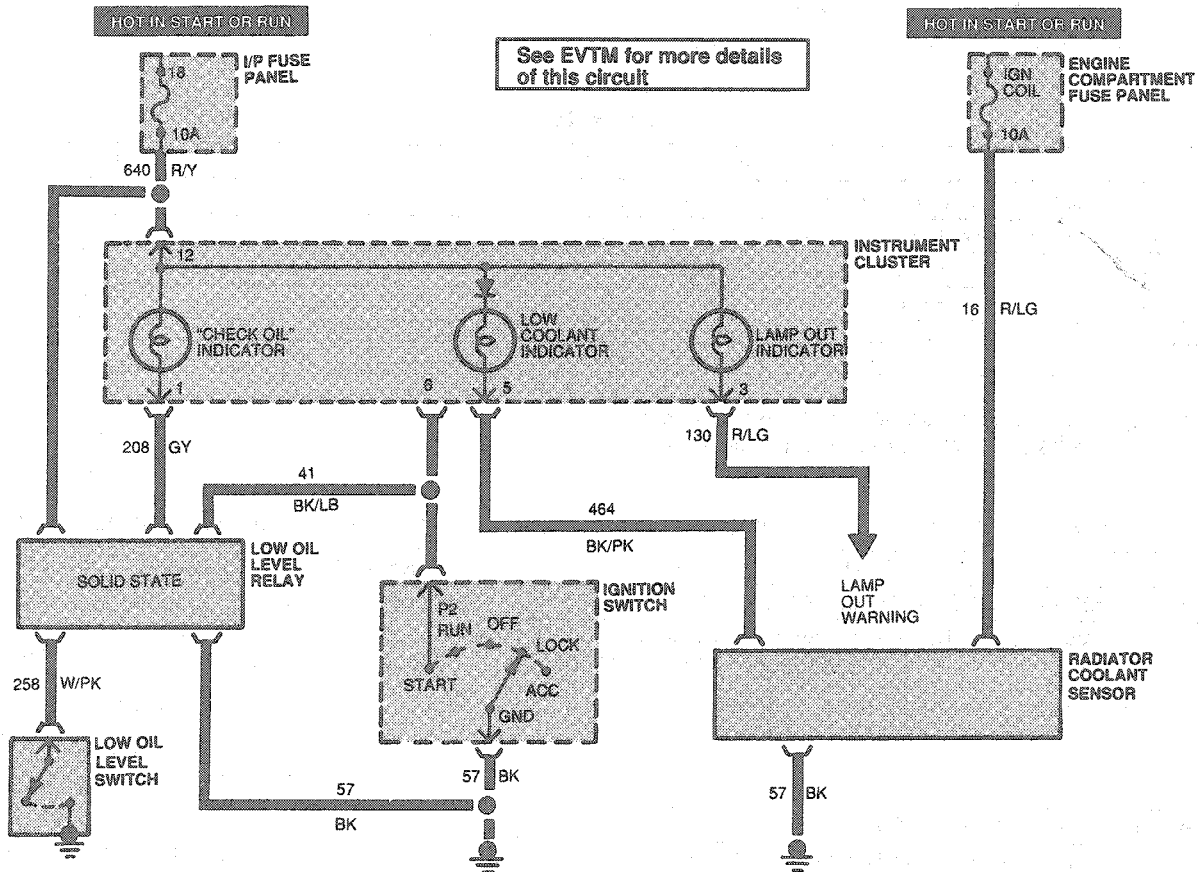

K17222-A

**PINPOINT TEST D: LOW COOLANT LEVEL INDICATOR INOPERATIVE**

TEST STEP	RESULT	ACTION TO TAKE
<b>D1</b> VERIFY COOLANT LEVEL		
<ul style="list-style-type: none"> <li>When the engine is cold observe level of coolant in recovery reservoir.</li> <li>Is coolant level below FULL HOT mark?</li> </ul>	Yes	GO to D2.
	No	GO to D3.
<b>D2</b> VERIFY COOLANT LEVEL		
<ul style="list-style-type: none"> <li>Fill coolant to the FULL HOT mark on the recovery reservoir.</li> <li>Start vehicle and observe CHECK COOLANT indicator.</li> <li>Does indicator illuminate then stay off?</li> </ul>	Yes	System OK.
	No	GO to D3.
<b>D3</b> CHECK INDICATOR		
<ul style="list-style-type: none"> <li>Turn ignition ON.</li> <li>Using a jumper wire, ground Circuit 464 (BR/PK) wire at instrument cluster connector.</li> <li>Does indicator turn on?</li> </ul>	Yes	GO to D4.
	No	REPLACE and CHECK COOLANT indicator or instrument cluster.

**DIAGNOSIS AND TESTING (Continued)**

**PINPOINT TEST D:  
LOW COOLANT LEVEL INDICATOR INOPERATIVE (Continued)**

TEST STEP		RESULT	ACTION TO TAKE
<b>D4</b>	<b>CHECK RESISTANCE</b>		
	<ul style="list-style-type: none"> <li>● Disconnect the instrument cluster.</li> <li>● Measure resistance from the instrument cluster Circuit 464 (BR/PK) wire to the coolant level sensor.</li> <li>● <b>Is resistance less than 5 ohms?</b></li> </ul>	Yes No	GO to D5. SERVICE / REPLACE Circuit 464 (BR/PK) wire.
<b>D5</b>	<b>CHECK VOLTAGE TO SENSOR</b>		
	<ul style="list-style-type: none"> <li>● Measure voltage on Circuit 16 (R/LG) at coolant level sensor.</li> <li>● <b>Is voltage at least 10 volts?</b></li> </ul>	Yes No	GO to D6. SERVICE / REPLACE 16 (R/LG) circuit from the 20 fuse link to coolant level sensor.
<b>D6</b>	<b>CHECK SENSOR GROUND</b>		
	<ul style="list-style-type: none"> <li>● Measure resistance from coolant level sensor wire, Circuit 57 (BK) to ground.</li> <li>● <b>Is resistance less than 5 ohms?</b></li> </ul>	Yes No	GO to D7. SERVICE / REPLACE Circuit 57 (BK).
<b>D7</b>	<b>CHECK COOLANT LEVEL SENSOR</b>		
	<ul style="list-style-type: none"> <li>● Turn ignition ON.</li> <li>● Using a jumper wire, jump the coolant level sensor wire Circuit 464 (BR/PK) to ground.</li> <li>● <b>Does indicator turn on?</b></li> </ul>	Yes No	REPLACE coolant level sensor. SERVICE / REPLACE the CHECK COOLANT indicator or instrument cluster.

**Lamp-Out Warning System**

**Tools Required:**

- Rotunda Digital Volt-Ohmmeter 014-00407

NOTE: For diagnosis of the warning indicators, refer to the appropriate Section in Group 13.

When performing diagnosis on the Lamp-Out Warning System, the voltage measurements must be taken using Rotunda Digital Volt / Ohmmeter 014-00407 or equivalent. While taking measurements do not touch metal probes. Doing so will cause incorrect readings.

The vehicle must be at room temperature for this check, 16-30°C (60-86°F).

Make sure no additional lamps (i.e. trailer) or other than original equipment bulbs are in use.

Use the following diagnosis charts and illustrations to diagnose concerns in the Lamp-Out Warning System.

DIAGNOSIS AND TESTING (Continued)

Lamp-Out Warning System

Module Power and Cluster Connections

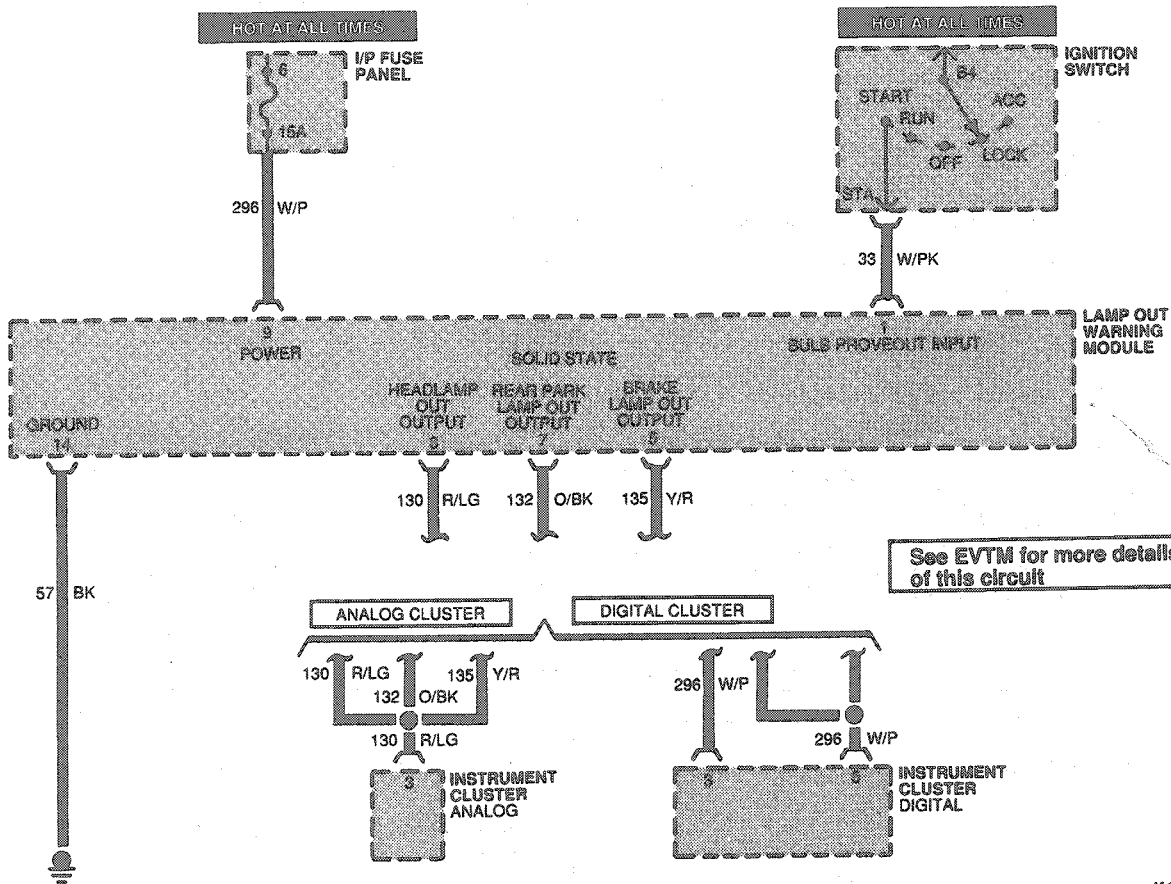

K17218-A

DIAGNOSIS AND TESTING (Continued)

Headlamp Circuit

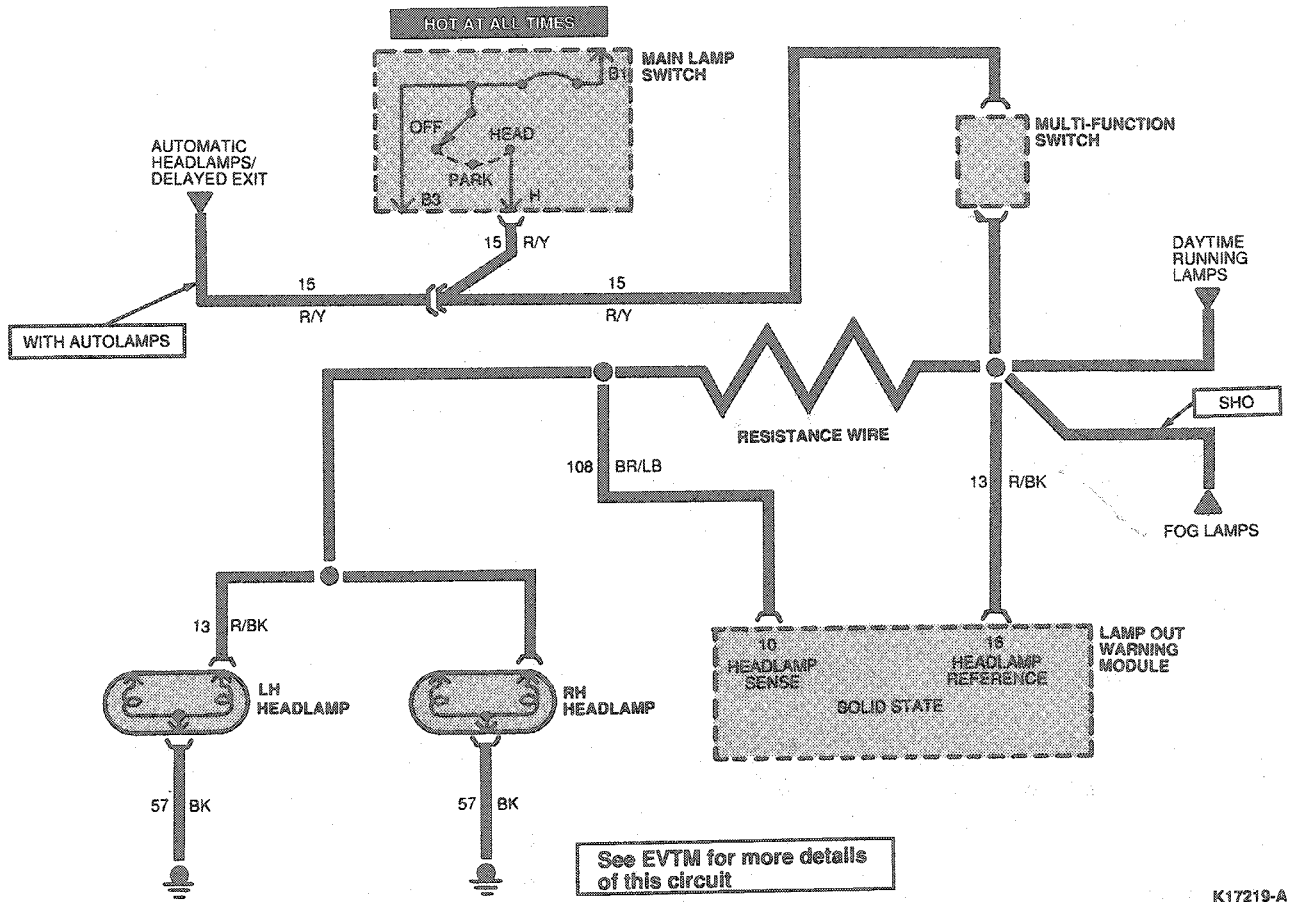

K17219-A

DIAGNOSIS AND TESTING (Continued)

Parking/Stop/Turn Lamp—Sedan

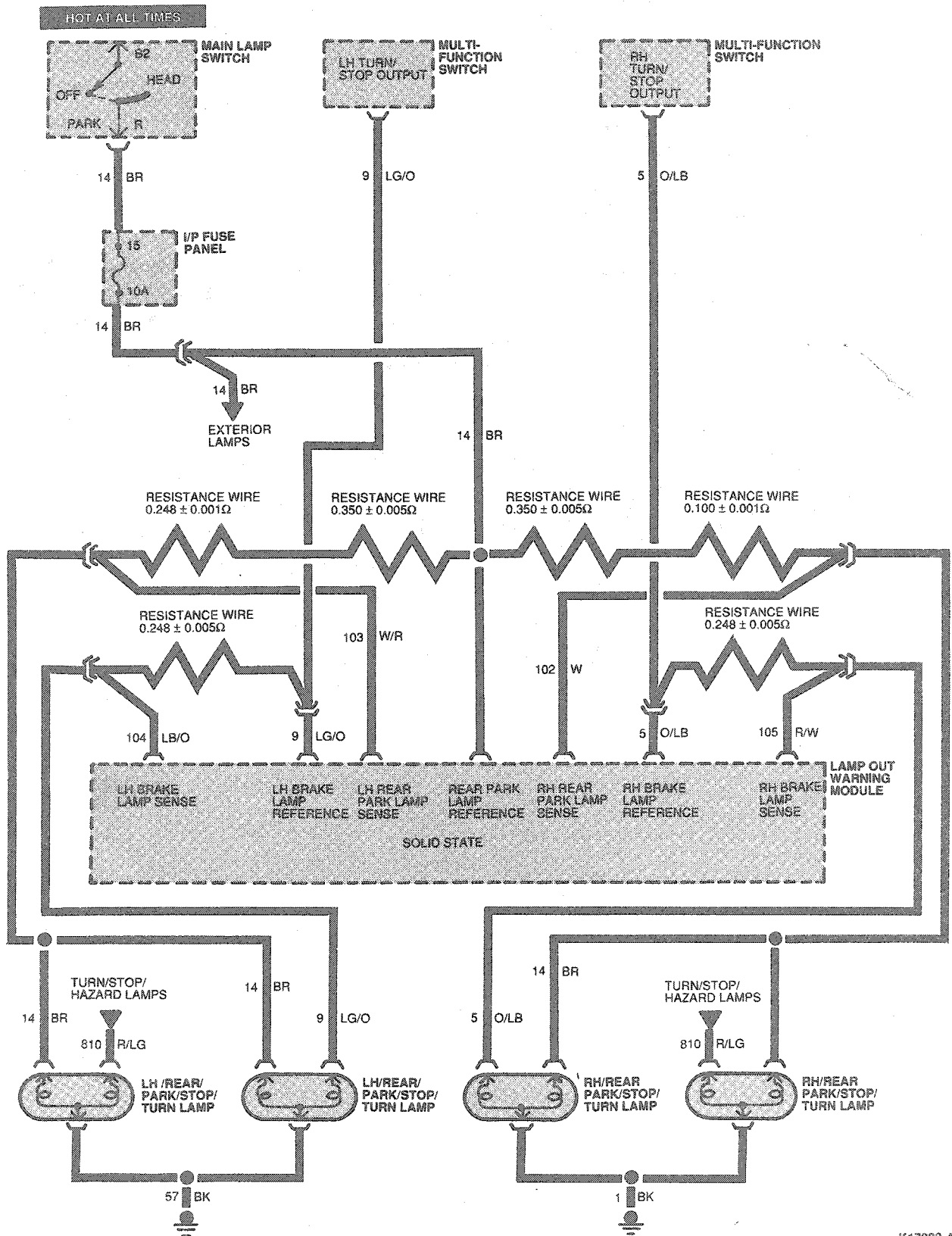

K17220-A



DIAGNOSIS AND TESTING (Continued)

Parking/Stop/Turn Lamp—Wagon

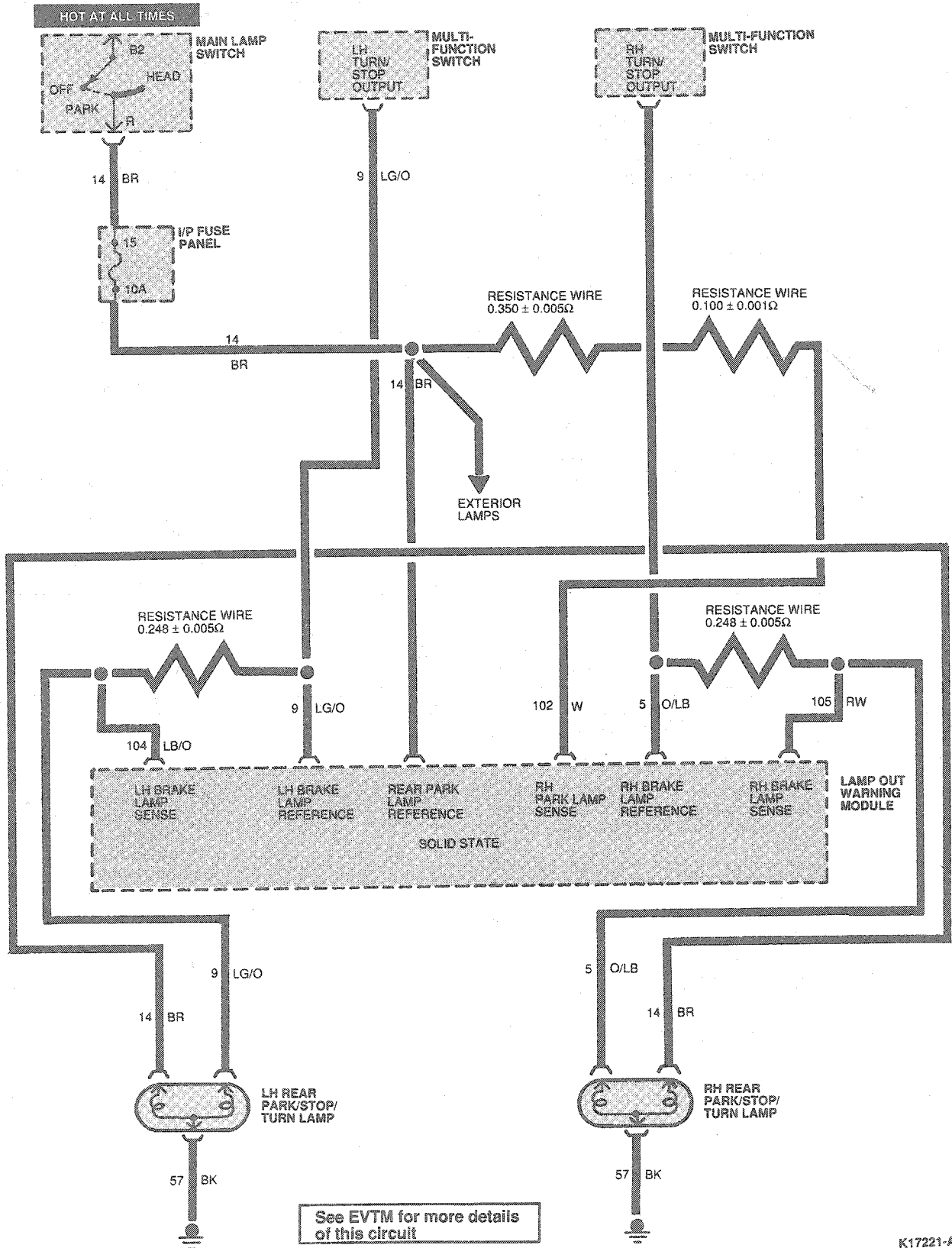

K17221-A

**DIAGNOSIS AND TESTING (Continued)**

**LAMP-OUT WARNING SYSTEM: QUICK TEST** Lamp-out warning not displayed when a lamp is burned out OR Lamp-out warning is displayed without an actual lamp failure

TEST STEP		RESULT	ACTION TO TAKE
Step 1	VERIFY THE CONDITION		GO to Step 2.
Step 2	CHECK HEADLAMPS, TAIL LAMPS AND BRAKELAMPS		
	<ul style="list-style-type: none"> <li>● Turn ignition switch to ACC or RUN.</li> <li>● Turn on low beam headlamps and brakelamps.</li> <li>● Are headlamps, rear parking lamps and brakelamps working properly?</li> </ul>	Yes No	GO to Step 3. SERVICE fuses, switches, bulbs, sockets or wiring as necessary. REPEAT test.
Step 3	CHECK WARNING INDICATORS		
	<ul style="list-style-type: none"> <li>● For vehicle with conventional cluster: Is LAMP OUT indicator on?</li> <li>● For vehicle with electronic cluster: Are HEADLAMP OUT and REAR LAMP OUT indicators on?</li> </ul>	Yes No	GO to Step 4. REFER to Pinpoint Test B as outlined to complete system verification.
Step 4	DISCONNECT LAMP-OUT MODULE		
	<ul style="list-style-type: none"> <li>● Turn lamps and ignition OFF.</li> <li>● Disconnect lamp-out module.</li> <li>● Turn lamps and ignition ON.</li> <li>● Is outage warning still being displayed?</li> </ul> <p>NOTE: Voltage measurements must use Rotunda Digital Volt / Ohmmeter 014-00407, 007-00001 or equivalent.</p>	Yes    No	CHECK outage indicator circuits for shorts to ground: 135 (Y/R) (module Pin 5) 132 (O/BK) (module Pin 7) 130 (R/LG) (module Pin 8) SERVICE as necessary. REPEAT test.  REFER to Pinpoint Test A as outlined.

TK13184C

**PINPOINT TEST A**  
**LAMP-OUT WARNING ILLIMINATED WHEN LAMPS ARE OPERATING PROPERLY**

TEST STEP		RESULT	ACTION TO TAKE
A1	CHECK REFERENCE VOLTAGES AT HARNESS CONNECTOR		
	<ul style="list-style-type: none"> <li>● Disconnect module.</li> <li>● Check voltage between ground Circuit 57 (BK) and the reference circuits of the lamp outage module harness connector. The voltage should be between 10 and 15 volts:                             <ul style="list-style-type: none"> <li>— Check voltage between Pin 14 (ground Circuit 57 BK) and Pin 13 (LH brake lamp reference Circuit 9 LG/O).</li> <li>— Check voltage between Pin 14 (ground Circuit 57 BK) and Pin 3 (RH brakelamp reference Circuit 5 O/LB).</li> <li>— Check voltage between Pin 14 (ground Circuit 57 BK) and Pin 15 (parking lamp reference Circuit 14 BR).</li> <li>— Check voltage between Pin 14 (ground Circuit 57 BK) and Pin 16 (headlamp reference Circuit 505 GY/Y).</li> </ul> </li> <li>● Is voltage between 10 and 15 volts?</li> </ul>	Yes No	GO to A2. CHECK circuits for opens or high resistance. CHARGE vehicle if necessary. REPEAT diagnostic test.

**DIAGNOSIS AND TESTING (Continued)**

**PINPOINT TEST A  
LAMP-OUT WARNING ILLUMINATED WHEN LAMPS ARE OPERATING PROPERLY (Continued)**

TEST STEP		RESULT	ACTION TO TAKE																								
<b>A2</b>	<p><b>CHECK FOR CROSSED CIRCUITS</b></p> <ul style="list-style-type: none"> <li>Checks for crossed circuits by energizing all light circuits individually. Verify voltage between reference and ground, then between sensor and ground.</li> <li>Corresponding reference and sense terminals should be the only ones with voltage (9 volts minimum) and reference circuits should measure higher (with respect to vehicle ground) than sense circuits.</li> </ul> <p><b>HARNES CONNECTOR PIN (CIRCUIT NUMBER, COLORS)</b></p> <table border="1"> <thead> <tr> <th>Exterior Light</th> <th>Reference</th> <th>Sense</th> <th>Ground</th> </tr> </thead> <tbody> <tr> <td>LH turn signal only (this is the LH brakelamp filament also)</td> <td>13 (9 LG/O)</td> <td>11 (104 LB/O)</td> <td>14 (57 BK)</td> </tr> <tr> <td>RH turn signal only (this is the RH brakelamp filament also)</td> <td>3 (5 O/LB)</td> <td>2 (105 R/W)</td> <td>14 (57 BK)</td> </tr> <tr> <td>Parking lamps only on (FOR SEDANS: this is the LH parking lamp filament only. FOR WAGONS: this is both the LH and RH parking lamp filaments)</td> <td>15 (14 BR)</td> <td>4 (102 W)</td> <td>14 (57 BK)</td> </tr> <tr> <td>Parking lamps only on FOR SEDANS ONLY: this is the RH parking lamp filament</td> <td>15 (14 BR)</td> <td>12 (103 W/R)</td> <td>14 (57 BK)</td> </tr> <tr> <td>Headlamps (both LH and RH)</td> <td>16 (505 GY/Y)</td> <td>10 (108 BR/LB)</td> <td>14 (57 BK)</td> </tr> </tbody> </table> <ul style="list-style-type: none"> <li>Are all circuits OK?</li> </ul>	Exterior Light	Reference	Sense	Ground	LH turn signal only (this is the LH brakelamp filament also)	13 (9 LG/O)	11 (104 LB/O)	14 (57 BK)	RH turn signal only (this is the RH brakelamp filament also)	3 (5 O/LB)	2 (105 R/W)	14 (57 BK)	Parking lamps only on (FOR SEDANS: this is the LH parking lamp filament only. FOR WAGONS: this is both the LH and RH parking lamp filaments)	15 (14 BR)	4 (102 W)	14 (57 BK)	Parking lamps only on FOR SEDANS ONLY: this is the RH parking lamp filament	15 (14 BR)	12 (103 W/R)	14 (57 BK)	Headlamps (both LH and RH)	16 (505 GY/Y)	10 (108 BR/LB)	14 (57 BK)	<p>Yes</p> <p>No</p>	<p>GO to A3.</p> <p>SERVICE circuits.</p>
Exterior Light	Reference	Sense	Ground																								
LH turn signal only (this is the LH brakelamp filament also)	13 (9 LG/O)	11 (104 LB/O)	14 (57 BK)																								
RH turn signal only (this is the RH brakelamp filament also)	3 (5 O/LB)	2 (105 R/W)	14 (57 BK)																								
Parking lamps only on (FOR SEDANS: this is the LH parking lamp filament only. FOR WAGONS: this is both the LH and RH parking lamp filaments)	15 (14 BR)	4 (102 W)	14 (57 BK)																								
Parking lamps only on FOR SEDANS ONLY: this is the RH parking lamp filament	15 (14 BR)	12 (103 W/R)	14 (57 BK)																								
Headlamps (both LH and RH)	16 (505 GY/Y)	10 (108 BR/LB)	14 (57 BK)																								
<b>A3</b>	<p><b>CHECK VOLTAGE BETWEEN REFERENCE AND SENSE PINS</b></p> <ul style="list-style-type: none"> <li>Voltage between corresponding Reference and Sense circuits when each light circuit is turned on individually.</li> <li>The voltage should be approximately 0.50 volt.</li> </ul> <p><b>HARNES CONNECTOR PIN (Circuit number, colors)</b></p> <table border="1"> <thead> <tr> <th>Exterior Light</th> <th>Reference</th> <th>Sense</th> </tr> </thead> <tbody> <tr> <td>LH turn signal only (this is the LH brakelamp filament also)</td> <td>13 (9 LG/O)</td> <td>11 (104 LB/O)</td> </tr> <tr> <td>RH turn signal only (this is the RH brakelamp filament also)</td> <td>3 (5 O/LB)</td> <td>2 (105 R/W)</td> </tr> <tr> <td>Parking lamps only on (FOR SEDANS: this is the LH parking lamp filament only. FOR WAGONS: this is both the LH and RH parking lamp filaments)</td> <td>15 (14 BR)</td> <td>4 (102 W)</td> </tr> <tr> <td>Parking lamps only on (FOR SEDANS ONLY: this is the RH parking lamp filament)</td> <td>15 (14 BR)</td> <td>12 (103 W/R)</td> </tr> <tr> <td>Headlamps (both LH and RH)</td> <td>16 (505 GY/Y)</td> <td>10 (108 BR/LB)</td> </tr> </tbody> </table> <ul style="list-style-type: none"> <li>Are all voltages OK?</li> </ul>	Exterior Light	Reference	Sense	LH turn signal only (this is the LH brakelamp filament also)	13 (9 LG/O)	11 (104 LB/O)	RH turn signal only (this is the RH brakelamp filament also)	3 (5 O/LB)	2 (105 R/W)	Parking lamps only on (FOR SEDANS: this is the LH parking lamp filament only. FOR WAGONS: this is both the LH and RH parking lamp filaments)	15 (14 BR)	4 (102 W)	Parking lamps only on (FOR SEDANS ONLY: this is the RH parking lamp filament)	15 (14 BR)	12 (103 W/R)	Headlamps (both LH and RH)	16 (505 GY/Y)	10 (108 BR/LB)	<p>Yes</p> <p>No</p>	<p>REPLACE lamp-out module.</p> <p>GO to A4.</p>						
Exterior Light	Reference	Sense																									
LH turn signal only (this is the LH brakelamp filament also)	13 (9 LG/O)	11 (104 LB/O)																									
RH turn signal only (this is the RH brakelamp filament also)	3 (5 O/LB)	2 (105 R/W)																									
Parking lamps only on (FOR SEDANS: this is the LH parking lamp filament only. FOR WAGONS: this is both the LH and RH parking lamp filaments)	15 (14 BR)	4 (102 W)																									
Parking lamps only on (FOR SEDANS ONLY: this is the RH parking lamp filament)	15 (14 BR)	12 (103 W/R)																									
Headlamps (both LH and RH)	16 (505 GY/Y)	10 (108 BR/LB)																									

## DIAGNOSIS AND TESTING (Continued)

**PINPOINT TEST A**  
**LAMP-OUT WARNING ILLUMINATED WHEN LAMPS ARE OPERATING PROPERLY (Continued)**

TEST STEP		RESULT	ACTION TO TAKE
<b>A4</b>	<b>SUBSTITUTE NEW BULBS</b>		
	<ul style="list-style-type: none"> <li>● Substitute new bulbs for lamps indicated by warning.</li> <li>● Reconnect lamp-out module and re-test.</li> <li>● Are lamps OK?</li> </ul>	Yes No	<ul style="list-style-type: none"> <li>▶ LEAVE in new bulbs.</li> <li>▶ SERVICE affected wiring harness: Headlamps — 14401 Tail lamps or Brakelamps — 14405</li> </ul>

TK17157B

**PINPOINT TEST B: LAMP-OUT WARNING NOT ILLUMINATED WHEN ONE OF MORE LAMPS ARE NOT OPERATING PROPERLY**

TEST STEP		RESULT	ACTION TO TAKE
<b>B1</b>	<b>CHECK FUSE AND CONNECTOR</b>		
	<ul style="list-style-type: none"> <li>● Check system fuse.</li> <li>● Check wiring connector to outage indicator lamps.</li> <li>● Are fuse and connector OK?</li> </ul>	Yes No	<ul style="list-style-type: none"> <li>▶ GO to B2.</li> <li>▶ SERVICE and/or REPLACE as necessary.</li> </ul>
<b>B2</b>	<b>CHECK INPUTS TO THE WARNING INDICATORS</b>		
	<b>FOR CONVENTIONAL CLUSTER:</b> <ul style="list-style-type: none"> <li>● Disconnect lamp out module.</li> <li>● Check if LAMP OUT indicator lights when you:               <ul style="list-style-type: none"> <li>— Turn ignition to ACC or RUN.</li> <li>— Ground Pin 5, Circuit 135 (Y/R) (brakelamp outage circuit).</li> <li>— Does LAMP OUT indicator light?</li> <li>— Shut OFF ignition to reset conventional cluster.</li> <li>— Turn ignition to ACC or RUN.</li> <li>— Ground Pin 7, Circuit 132 O/BK (the rear parking lamp outage circuit).</li> <li>— Does LAMP OUT indicator light?</li> <li>— Shut off ignition to reset conventional cluster.</li> <li>— Turn ignition to ACC or RUN.</li> <li>— Ground Pin 8, Circuit 130 R/LG (the headlamp outage circuit).</li> <li>— Does LAMP OUT indicator light?</li> </ul> </li> <li>● Does LAMP OUT indicator light when circuits are individually grounded?</li> </ul> <b>FOR ELECTRONIC CLUSTER:</b> <ul style="list-style-type: none"> <li>● Disconnect lamp out module.</li> <li>● Check if warning indicator lights when you:               <ul style="list-style-type: none"> <li>— Turn ignition to ACC or RUN.</li> <li>— Ground Pin 5, Circuit 135 (Y/R) (the brakelamp outage circuit).</li> <li>— Does REAR LAMP OUT indicator light?</li> <li>— Shut OFF ignition to reset electronic cluster.</li> <li>— Turn ignition to ACC or RUN.</li> <li>— Ground Pin 7, Circuit 132 (O/BK) (the rear parking lamp outage circuit).</li> <li>— Does REAR LAMP OUT indicator light?</li> <li>— Shut OFF ignition to reset electronic cluster.</li> <li>— Turn ignition to ACC or RUN.</li> <li>— Ground Pin 8, Circuit 130 (R/LG) (the head lamp outage circuit).</li> <li>— Does HEADLAMP OUT indicator light?</li> </ul> </li> <li>● Does LAMP OUT indicator appear when circuits are individually grounded?</li> </ul>	Yes No	<ul style="list-style-type: none"> <li>▶ REPLACE lamp out warning module.</li> <li>▶ SERVICE appropriate wiring of bulbs as necessary.</li> </ul>

**DIAGNOSIS AND TESTING (Continued)**

**PINPOINT TEST C: LAMP OUT WARNING SYSTEM: Verification if outage is detected if lamps are disconnected**

TEST STEP		RESULT	ACTION TO TAKE
C1	CHECK WARNING INDICATORS	Yes	System OK. Test complete.
	<ul style="list-style-type: none"> <li>● Turn OFF headlamps, tail lamps and brakelamps.</li> <li>● Disconnect one headlamp and two tail lamps (includes brakelamp filaments), one from left and right.</li> <li>● Connect lamp-out module.</li> <li>● Turn ignition to ACC or RUN.</li> <li>● Turn on headlamps (low beam) and brakelamps.</li> <li>● Are all lamp-out warning indicators illuminated?</li> </ul>	No	GO to Pinpoint Test A, Step A1.

TK5980H

**Lamp-Out Module Connector Pin-Out**

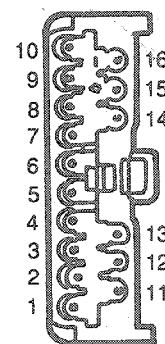
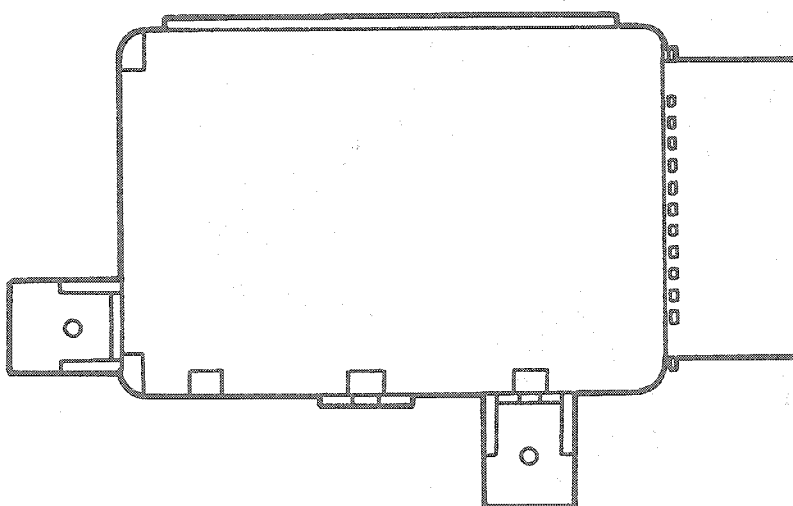

**16-PIN HARNESS CONNECTOR**

K17135-A

Pin	Circuit	Color	Function
1	33	W/P	Start (Prove-Out)
2	105	R/W	RH Stop Lamp Sense
3	5	O/LB	RH Stop Lamp Reference
4	102	W	LH Park Lamp Sense (LH and RH Rear Park Lamp Sense for Wagons)
5	135	Y/R	Brakelamp Outage
6	573	BK/O	Center Tail Lamp Sense (Sable Sedan)
7	132	O/BK	Tail Lamp Outage
8	130	R/LG	Headlamp Outage
9	296	W/P	RUN / ACC
10	108	BR/LB	Headlamp Sense
11	104	LB/O	LH Stop Lamp Sense
12	103	W/R	RH Rear Park Lamp Sense (Sedan Only)
13	9	LG/O	LH Stop Lamp Reference
14	57	BK	Ground
15	14	BR	Rear Park Lamp Reference
16	505	GY/Y	Headlamp Reference

**REMOVAL AND INSTALLATION**

**Warning Chime**

**Removal and Installation**

The warning chime module is mounted on a bracket to the RH side of the steering column, on the instrument panel reinforcement.

1. Disconnect battery ground cable.

2. Depress tab on warning chime module and slide module off bracket.
3. Disconnect electrical connector to warning chime.
4. Remove chime.
5. To install, reverse Removal procedure.

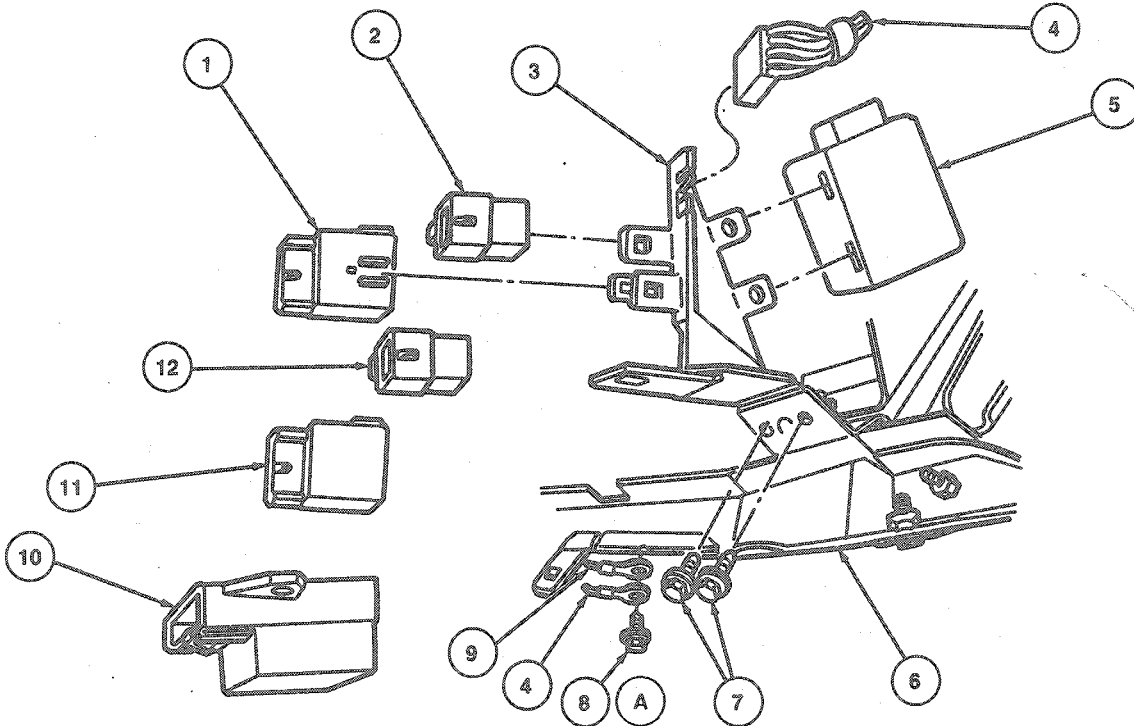

K16929-B

Item	Part Number	Description
1	6C625	Low Oil Indicator Assy
2	14B193	Horn Relay Assy
3	14A323	Relay Panel Bracket Assy
4	14401	Wiring Assy
5	17D539	Wiper Control Module
6	5404304	Instrument Panel Assy
7	N803876-S36	Screw (2 Req'd)

Item	Part Number	Description
8A	N805375-S36MG	Ground Screw
9	14401	Wiring Assy Ground (for Canadian Vehicles Only)
10	10D840	Chime Assy
11	18C641	Rear Window Defroster Timer (Sable)
12	14B193	Horn Relay Assy
A		Tighten to 12 N-m (9 Lb-Ft)

(Continued)

**Lamp-Out Warning Module**

**Except Taurus SHO**

**Removal and Installation**

1. Pull down fuse panel.

2. Remove two nuts retaining lamp outage module.
3. Disconnect electrical connector.

**REMOVAL AND INSTALLATION (Continued)**

4. To install, reverse Removal procedure.

LAMP OUTAGE  
MODULE 10K910

NUT AND  
WASHER ASSY  
45320-S36

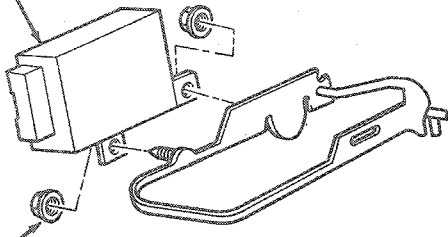

K17133-B

**Taurus SHO**

**Removal and Installation**

1. Remove glove compartment.
2. Remove screw retaining module to instrument panel.
3. Disconnect electrical connectors.
4. To install, reverse Removal procedure.

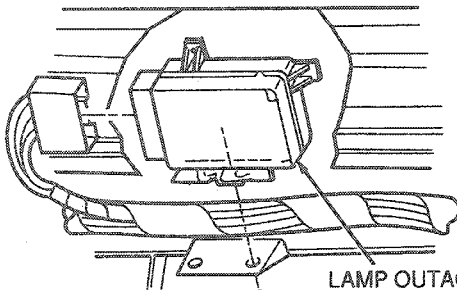

SCREW  
N611037-S2

LAMP OUTAGE  
MODULE  
10K910

K17134-B

**Low Oil Level Sensor**

**Removal and Installation**

1. With engine off, drain at least 1.9L (2 qt) of oil from engine.
2. Disconnect electrical connection.
3. Remove sensor with a 26mm (1 inch) socket or end wrench. Discard old gasket.
4. To install, reverse Removal procedure.

GASKET  
6C626  
INSTALL WITH WORDS  
"PAN SIDE" TOWARD  
OIL PAN

SENSOR-OIL LEVEL  
6C624  
TIGHTEN TO  
20-34 N·m  
(15-25 LB-FT)

OIL PAN  
ASSY  
06675

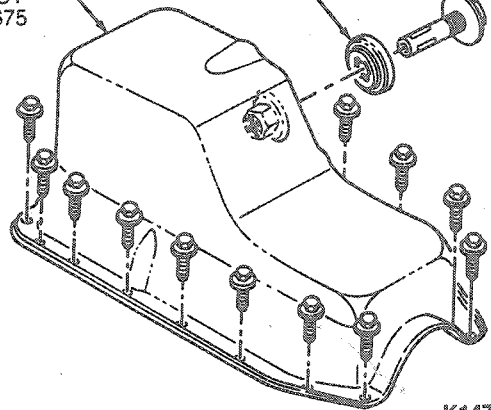

K14774-C

**Low Coolant Level Sending Unit**

**Removal and Installation**

1. Disconnect electrical connector to coolant level sending unit.
2. Remove coolant level sending unit from coolant recovery reservoir.
3. To install, reverse Removal procedure and verify proper operation.

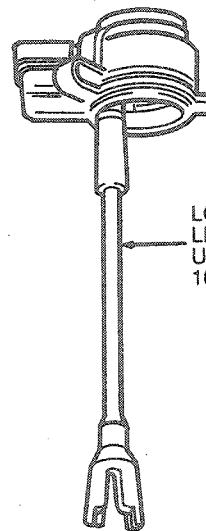

LOW COOLANT  
LEVEL SENDING  
UNIT  
10D968

K17131-B

## SPECIFICATIONS

## TORQUE SPECIFICATIONS

Description	N-m	Lb-Ft
Oil Level Sensor	20-34	15-25
Ground Screw	12	9

## SPECIAL SERVICE TOOLS

## ROTUNDA EQUIPMENT

Model	Description
007-00001	Digital Volt-Ohmmeter
014-00407	Digital Volt-Ohmmeter