

SECTION 13-02 Speedometer/Odometer

SUBJECT	PAGE	SUBJECT	PAGE
DESCRIPTION AND OPERATION	13-02-1	REMOVAL AND INSTALLATION	
DIAGNOSIS AND TESTING.....	13-02-1	Speedometer Assembly.....	13-02-3
MAJOR SERVICE OPERATIONS		Speedometer Cables.....	13-02-3
Drive and Driven Gears, Damaged.....	13-02-5	Vehicle Speed Sensor (VSS).....	13-02-3
Speedometer System Noisy.....	13-02-5	SPECIFICATIONS.....	13-02-5
PARTS CROSS-REFERENCE	13-02-6	VEHICLE APPLICATION	13-02-1

VEHICLE APPLICATION

Taurus / Sable.

DESCRIPTION AND OPERATION

The speedometer is connected to the output shaft of the transaxle by means of a flexible shaft (core), and a drive gear located inside the transaxle. The core drives the speedometer and also drives an odometer.

The core or flexible shaft is housed in a flexible casing.

DIAGNOSIS AND TESTING

The Ford Car Master Parts catalog and the Lincoln/Mercury Parts and Accessories catalog show the proper speedometer transmission gears to use for various transaxle and tire size combinations. The correct gears must be used to comply with Federal law.

The diagnosis charts should be used to isolate concerns in the non-electronic speedometer.

PINPOINT TEST A: SPEEDOMETER/ODOMETER NOISY, ERRATIC, INOPERATIVE OR INACCURATE

TEST STEP	RESULT	ACTION TO TAKE
A1 VERIFY CONDITION		
<ul style="list-style-type: none"> Make sure quick connect is properly attached at speedometer head. Make sure cable is connected at the speed sensor, if applicable. 	Noisy Erratic or pointer waver Inoperative speed indication Inoperative odometer Inaccurate speed indication	GO to A2. GO to A3. GO to A7. GO to A8. GO to A15.
A2 CHECK FOR NOISE		
<ul style="list-style-type: none"> With engine running in NEUTRAL, check for noise. Is noise present? 	Yes No	CHECK for other causes of vehicle noise. GO to A3.
A3 CHECK CABLE		
<ul style="list-style-type: none"> Check cable for kinks or bends. Is cable OK? 	Yes No	GO to A4. If kinks are severe, REPLACE cable. For minor bends, ADJUST cable routing to obtain generous curves and RECHECK for condition resolution.

DIAGNOSIS AND TESTING (Continued)

PINPOINT TEST A: SPEEDOMETER/ODOMETER NOISY, ERRATIC, INOPERATIVE OR INACCURATE (Continued)

TEST STEP		RESULT	ACTION TO TAKE
A4	CHECK CABLE		
	<ul style="list-style-type: none"> ● Disconnect cable and check core for kinks, burrs or bent tips. ● Is cable OK? 	Yes No	GO to A5. REPLACE cable.
A5	CHECK VEHICLE SPEED SENSOR (VSS) 9E731		
	<ul style="list-style-type: none"> ● Remove vehicle speed sensor (VSS), check for erratic or noisy operation. ● Is speed sensor OK? 	Yes No	GO to A6. REPLACE vehicle speed sensor (VSS).
A6	CHECK DRIVEN GEAR		
	<ul style="list-style-type: none"> ● Check for damaged driven gear. ● Is driven gear OK? 	Yes No	REPLACE speedometer head. REPLACE gear.
A7	CHECK ODOMETER		
	<ul style="list-style-type: none"> ● Check to see that odometer is operating. ● Does odometer operate properly? 	Yes No	REPLACE speedometer head. GO to A9.
A8	CHECK POINTER OPERATION		
	<ul style="list-style-type: none"> ● Check to see that pointer operates. ● Does pointer operate properly? 	No Yes	GO to A9. REPLACE speedometer head.
A9	VERIFY CABLE CONNECTIONS		
	<ul style="list-style-type: none"> ● Check and verify that cable is properly connected to speedometer and to speed sensor. ● Is cable connected properly? 	Yes No	GO to A10. SERVICE cable connections as required.
A10	CHECK MAGNET SHAFT		
	<ul style="list-style-type: none"> ● Disconnect cable and check that magnet shaft in speedometer head turns freely. ● Does magnet shaft turn freely? 	Yes No	GO to A11. REPLACE speedometer head.
A11	CHECK DRIVE AND DRIVEN GEAR		
	<ul style="list-style-type: none"> ● Check drive and driven gear for damage or wear. ● Are both gears OK? 	Yes No	GO to A12. REPLACE damaged gear.
A12	CHECK CABLE		
	<ul style="list-style-type: none"> ● Check speedometer cable for kinks or improper routing. ● Is cable OK? 	Yes No	GO to A13. REPLACE cable.
A13	CHECK SENSOR SHAFT		
	<ul style="list-style-type: none"> ● Disconnect cable from vehicle speed sensor (VSS). Remove sensor and check that shaft in sensor turns freely. ● Does sensor shaft turn freely? 	Yes No	GO to A14. REPLACE vehicle speed sensor (VSS).
A14	CHECK CORE		
	<ul style="list-style-type: none"> ● Check for broken core. ● Is core OK? 	Yes No	If core is seized and will not turn, REPLACE cable. REPLACE cable.
A15	CHECK ODOMETER/SPEEDOMETER ACCURACY		
	<ul style="list-style-type: none"> ● Check accuracy of odometer over a measured distance. Refer to Speedometer Calibration Tolerance Specifications. ● Is odometer accurate? 	Yes No	REPLACE speedometer head. GO to A16.
A16	CHECK DRIVEN GEAR		
	<ul style="list-style-type: none"> ● Check for proper driven gear. ● Is driven gear correct? 	Yes No	GO to A17. REPLACE gear.

DIAGNOSIS AND TESTING (Continued)

PINPOINT TEST A: SPEEDOMETER/ODOMETER NOISY, ERRATIC, INOPERATIVE OR INACCURATE (Continued)

TEST STEP		RESULT	ACTION TO TAKE
A17	CHECK DRIVE GEAR, AXLE AND TIRES		
	<ul style="list-style-type: none"> ● Check for proper drive gear, axle and tires. ● Are drive gear, axle and tires correct? 	Yes	▶ REPLACE speedometer assembly.
		No	▶ REPLACE incorrect component or driven gear.

TK5966E

REMOVAL AND INSTALLATION

Speedometer Assembly

Federal law requires that the odometer in any replacement speedometer must register the same mileage as that registered in the removed speedometer.

Refer to Section 13-01B for conventional speedometer removal and installation.

Refer to Section 13-01A for electronic speedometer removal and installation.

Speedometer Cables

Because of the increasing complexity of speedometer cable assemblies and the importance of proper routing during installation, installation and routing instructions are shown on the illustrations.

Vehicle Speed Sensor (VSS)

Refer to Section 10-03.

REMOVAL AND INSTALLATION (Continued)

QUICK CONNECT CABLE ATTACHMENT AND REMOVAL

TO INSTALL:
PUSH CABLE FITTING ON WITH A ROTATING MOTION UNTIL CONNECTOR ENGAGES INTO SPEEDOMETER HEAD DETENT.

TO REMOVE:
PRESS THUMB LATCH TO DISENGAGE AND PULL CABLE AWAY FROM SPEEDOMETER HEAD.

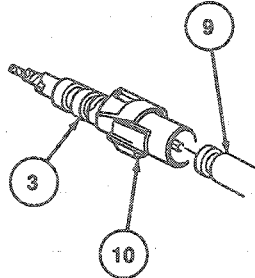

VIEW A

ROUTE SPEEDOMETER CABLE OVER ACCELERATOR CABLE AND SPEED CONTROL CABLE AS SHOWN

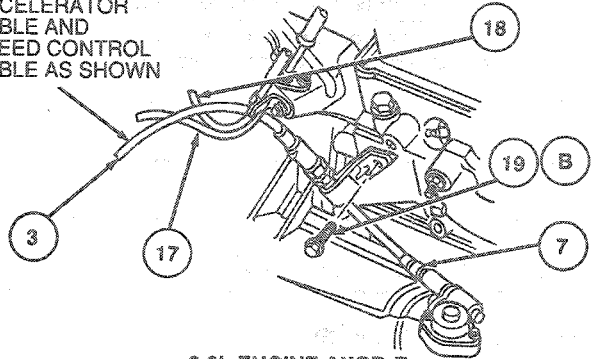

3.0L ENGINE AXOD-E TRANSAXLE
VIEW C

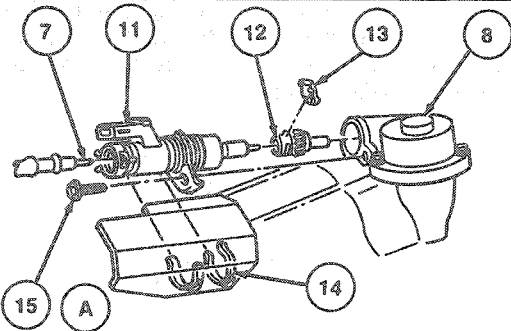

WITH STANDARD CLUSTER
VIEW B

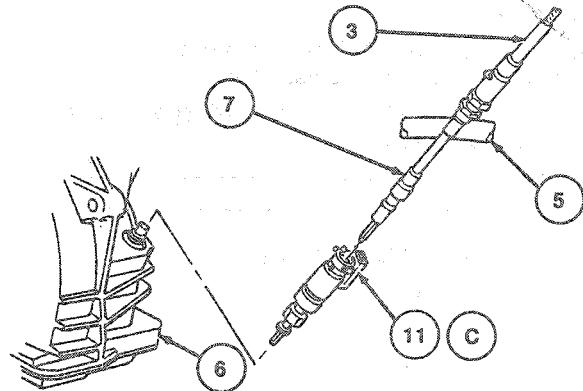

MANUAL TRANSAXLE WITH STANDARD CLUSTER
VIEW D

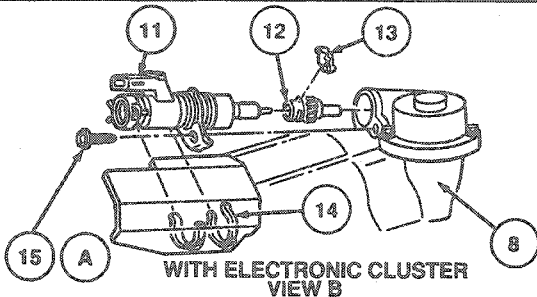

WITH ELECTRONIC CLUSTER
VIEW B

ROUTE CABLE AS SHOWN THROUGH HOLES IN SUPPORT BRACKET

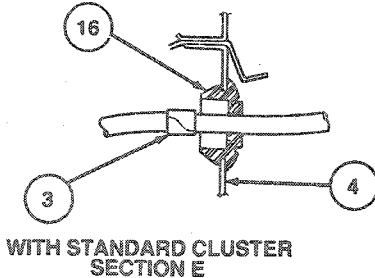
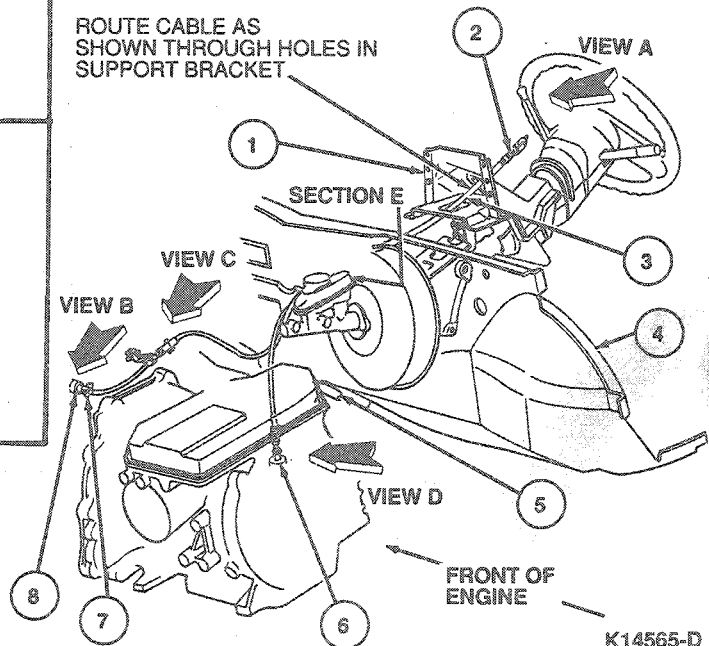

WITH STANDARD CLUSTER
SECTION E

K14565-D

REMOVAL AND INSTALLATION (Continued)

Item	Part Number	Description
1	03678	Support Bracket
2	—	To Speedometer
3	9A820	Speed Control Speedometer Cable
4	04304	Dash Panel
5	07A246	Pulse Air Tube
6	—	To MTX Transaxle
7	9F714	Speed Control Cable and Sensor
8	—	To AXOD-E Transaxle
9	17255	Speedometer Assy
10	—	Thumb Latch Part of 9A820 Speedometer Cable Assy
11C	9E731	Vehicle Speed Sensor (VSS)

(Continued)

Item	Part Number	Description
12	17271	Speedometer Gear
13	17292	Clip
14	9F829	Speed Sensor Shield
15A	N620529-S2	Bolt
16	389847-S	Grommet
17	9A758	Throttle Cable
18	9A820	Speed Control Speedometer Cable
19B	N605798-S2	Bolt
A		Tighten to 4-6 N·m (36-53 Lb·In)
B		Tighten to 18-27 N·m (14-19 Lb·Ft)
C		Tighten to 3-4 N·m (27-35 Lb·In)

MAJOR SERVICE OPERATIONS**Speedometer System Noisy**

Applying heavy amounts of lubricant to the cable core will only stop the noise temporarily unless the actual source of noise is found and corrected. If the speed sensor or speedometer head is replaced, ensure that the square drive holes contain a sufficient amount of Speedometer Cable Grease E6TZ-19581-A (ESF-M1C160-A) or equivalent. If not, apply a 4.6mm (3/16 inch) diameter ball of damping grease into the drive holes as required.

Drive and Driven Gears, Damaged

1. A scored, nicked or gouged driven gear is usually indicative of improper gear mesh on those vehicles that have the drive gear integral with the transaxle output shaft. The output shaft should be carefully inspected for imperfections and replaced if necessary.
2. A driven gear with two or three adjoining teeth badly scored is indicative of improper assembly procedure. The gear should be inserted in the transaxle while simultaneously turning the halfshafts. This will ensure initial gear engagement and prevent gear damage. **Never use force.**
3. Whenever a drive gear is replaced, a new driven gear should also be installed, regardless of its apparent condition.

SPECIFICATIONS**SPEEDOMETER CALIBRATION TOLERANCE SPECIFICATIONS**

Actual Speedometer or Odometer Value Indicated	48 km/h (30 mph) Actual Speed	97km/h (60 mph) Actual Speed	Odometer Measure Over Actual 16.1 km Distance (10 Mile)
Allowable Range	45-56 km/h (28-35 mph)	93-104 km/h (58-65 mph)	15.4-16.7 km (9.6-10.4 Miles)

SPECIFICATIONS (Continued)

TORQUE SPECIFICATIONS

Description	N-m	Lb-in
Speed Sensor Bolt (3.8L)	4-6	36-53
Transaxle Bolt (3.0L)	18-27	14-19 (Lb-Ft)
Vehicle Speed Sensor	3-4	27-35

SECTION 13-03 Fuel Gauge and Low Fuel Warning

SUBJECT	PAGE	SUBJECT	PAGE
DESCRIPTION AND OPERATION		DIAGNOSIS AND TESTING (Cont'd.)	
Fuel Filter	13-03-4	Preliminary Checks	13-03-4
Fuel Level Indicating System	13-03-1	PARTS CROSS-REFERENCE	13-03-11
Fuel Sending Unit	13-03-2	REMOVAL AND INSTALLATION	
Low Fuel Level Warning and Anti-Slosh Module	13-03-4	Fuel Gauge	13-03-10
DIAGNOSIS AND TESTING		Fuel Pump and Sender Assembly	13-03-8
Calibration Test	13-03-4	Low Fuel Level Warning Switch	13-03-10
Operational Test	13-03-4	SPECIAL SERVICE TOOLS	13-03-10
		VEHICLE APPLICATION	13-03-1

VEHICLE APPLICATION

Taurus/Sable.

DESCRIPTION AND OPERATION

The fuel indicating system covered in this Section is for conventional cluster applications only. For information on the fuel indicating system used with the electronic clusters, refer to Section 13-01A.

Fuel Level Indicating System

The fuel level indicating system is a magnetic-type indicating system, which consists of the sending unit located in the fuel tank (9002), an anti-slosh module located on the back of the instrument cluster, and a fuel gauge (9280) located in the instrument cluster.

The sending unit changes resistance according to the level of fuel in the fuel tank, which varies the current flow through the gauge. The pointer position varies proportionately to the current flow. In this system, the sending unit resistance is low when the fuel level is low and high when the fuel level is high.

The pointer of the magnetic gauge remains in relatively the same position when the ignition is turned to OFF position.

NOTE: An anti-slosh module has been added to dampen out fluctuating fuel signals from the sender.

DESCRIPTION AND OPERATION (Continued)

Fuel Sending Unit

The fuel sending unit is combined with the fuel pump assembly, and consists of a variable resistor controlled by the level of an attached float in the fuel tank. When the fuel level is low, resistance in the sender is low and movement of the fuel gauge indicator dial is minimal (from EMPTY position). When the fuel level is high, the resistance in the sender is high and gauge indicator dial movement is greater (further from the EMPTY position).

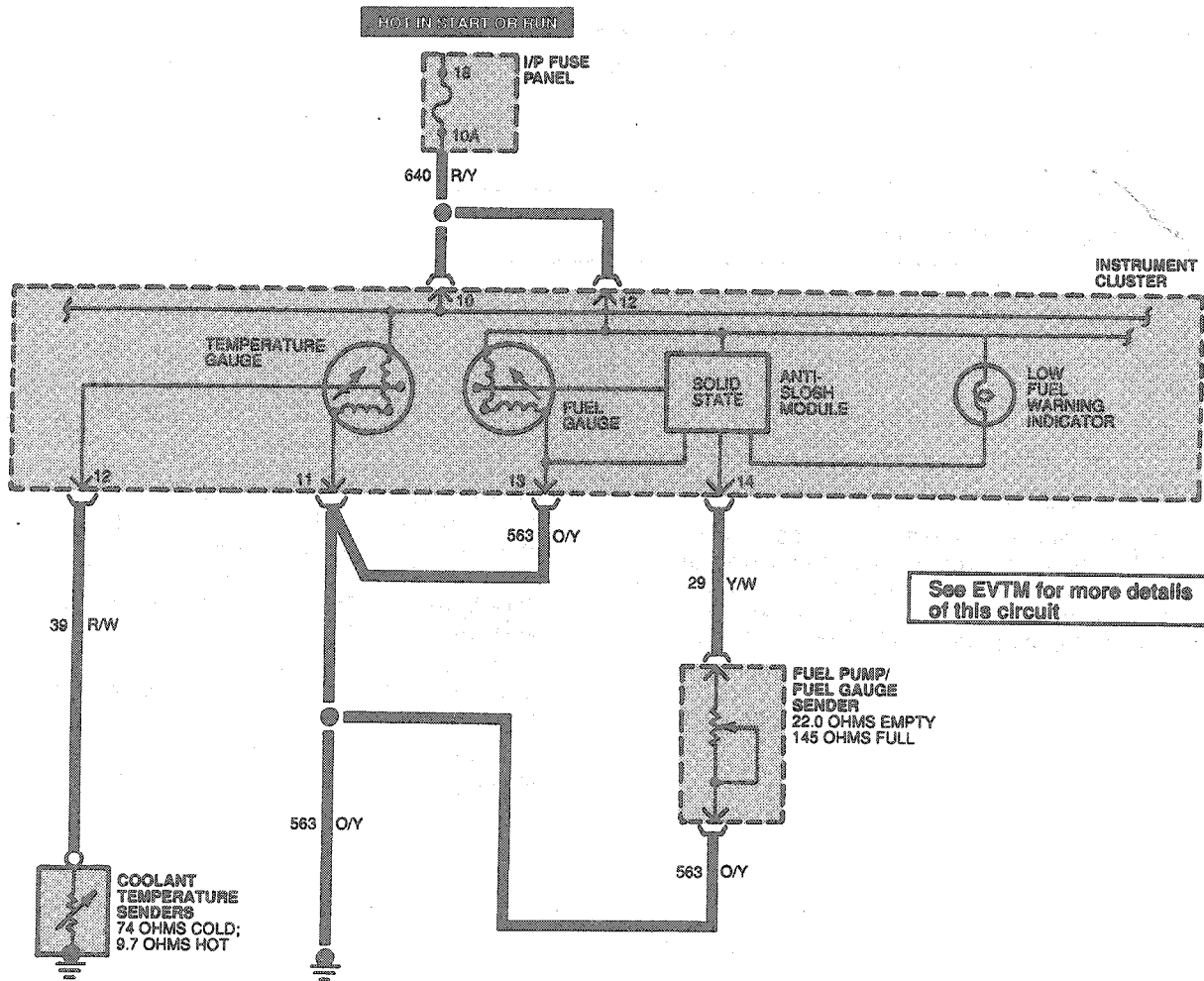

K17505-A

DESCRIPTION AND OPERATION (Continued)

Instrument Cluster Connections

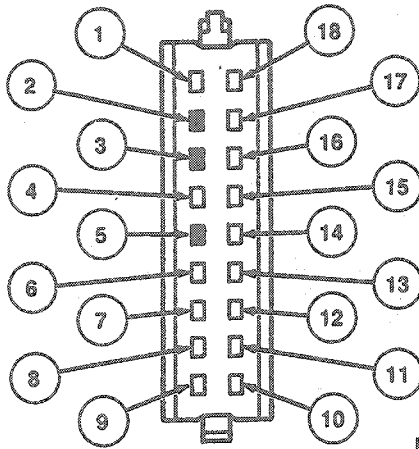

K18659-A

PIN NUMBER	CIRCUIT	CIRCUIT FUNCTION
1	19 (LB/R)	Instrument Panel Lamp Feed
2	—	Not Used
3	—	Not Used
4	82 (PK/Y)	Low Washer Fluid Indicator
5	—	Not Used
6	397 (BK/W)	Tachometer Ground
7	11 (T/Y)	Ignition Coil Neg. Terminal
8	31 (W/R)	Low Oil Pressure Indicator
9	608 (W/LB)	Temperature Gauge to Temperature Sending Unit
10	640 (R/Y)	Hot in RUN or START
11	563 (O/Y)	Ground Reference
12	39 (R/W)	Temperature Gauge to Coolant Temperature Sensor
13	977 (P/W)	Brake Warning Switch to Brake Warning Indicator
14	904 (LG/R)	Coil Terminal of Ignition Switch to Alternator/Regulator
15	16 (R/LG)	Ignition Switch to Ignition Coil "Battery" Terminal
16	19 (LB/R)	Instrument Panel Lamp Feed
17	3 (LG/W)	Left Turn Signals

(Continued)

PIN NUMBER	CIRCUIT	CIRCUIT FUNCTION
18	932 (GY/W) 12 (LG/BK)	Hi Beam Indicator to Daytime Running Lamps (DRL) Module Hi Beam of Headlamps

TK18659A

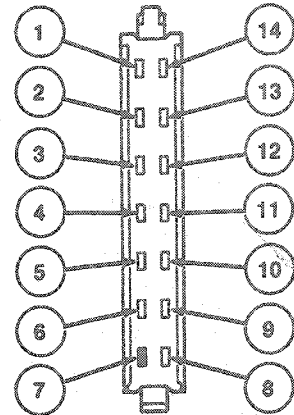

K18660-A

PIN NUMBER	CIRCUIT	CIRCUIT FUNCTION
1	208 (GY)	Low Oil Level Indicator Input
2	627 (BK/O)	Door/Liftgate Ajar Indicator to Warning Chime
3	130 (R/LG)	Lamp Out Indicator Input
4	57 (BK)	Ground
5	464 (BK/PK)	Radiator Coolant Sensor
6	41 (BK/LB)	Ignition Switch
7	—	NOT USED
8	2 (W/LB)	Right Turn Signal Indicator Input
9	450 (DG/LG)	Fasten Belts Indicator Input
10	201 (T/R)	Check Engine Indicator Input
11	608 (BK/Y)	Air Bag Indicator Input
12	640 (R/Y)	Hot in RUN or START
13	563 (O/Y)	Reference Ground
14	29 (Y/W)	Fuel Level Input

TK18660A

DESCRIPTION AND OPERATION (Continued)

Fuel Filter

The fuel tank sender filter (9A011) used on the fuel pump / sender assemblies is not serviceable. Should it become clogged or inoperative, the pump must be replaced.

Low Fuel Level Warning and Anti-Slosh Module

The low fuel warning feature is available on Taurus vehicles with the tachometer option and on Sable vehicles with a conventional instrument cluster. These clusters will have the combination anti-slosh / low fuel warning module.

The conventional Taurus instrument cluster contains a fuel anti-slosh only module.

The anti-slosh / low fuel warning module provides a delay to the fuel gauge to prevent the fuel gauge pointer from fluctuating as a result of excessive movement in the fuel tank. The anti-slosh / low fuel warning module has additional circuitry to turn on a LOW FUEL warning indicator when the fuel gauges shows approximately one-eighth tank of fuel remaining. The module is not designed to prove-out the LOW FUEL warning indicator, however the indicator may flash on momentarily just after ignition ON. In both cases, the module is a small printed circuit board which latches into a pocket on the back of the instrument cluster. The electrical connections for ignition, ground, input from fuel sender, output to fuel gauge and Low Fuel warning output (where equipped) are made through a spring-type connector on the module to the flex circuit on the cluster. There are no provisions for calibration or adjustment of the module.

Before troubleshooting low fuel warning symptoms, first observe fuel gauge indication. If fuel indication is erroneous, proceed to fuel gauge diagnosis then to low fuel warning diagnosis. If fuel indication is correct proceed directly to low fuel warning diagnosis.

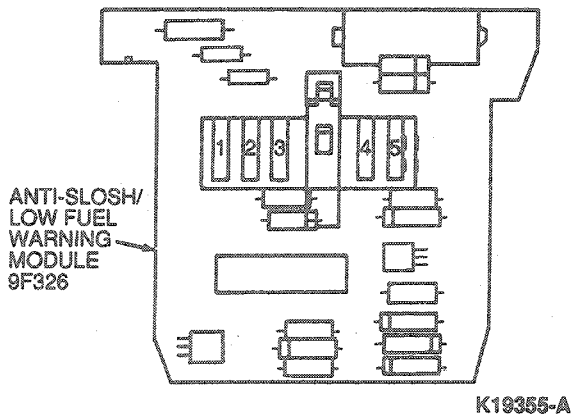
Anti-Slosh/Low Fuel Level Warning Module

DIAGNOSIS AND TESTING

Preliminary Checks

1. Visually inspect fuel tank for damage. A fuel tank that is collapsed or distorted from its normal shape will seriously affect fuel indicating system operation.
2. In some instances a fuel tank may not fill completely. This will result in the fuel gauge not reaching FULL mark. Check by shaking vehicle after first fuel blowback or pump nozzle cutoff and then slowly metering fuel into fuel tank with shut-off nozzle withdrawn to just inside the leaded fuel restrictor door. If fuel gauge reaches full after this procedure, fuel indication system is operating satisfactorily.

Operational Test**Tools Required:**

- Rotunda Instrument Gauge System Tester 021-00055

Follow the instructions with Rotunda Instrument Gauge System Tester 021-00055 or equivalent. If a tester is not available, refer to Pinpoint Tests A and B.

Calibration Test**Tools Required:**

- Rotunda Instrument Gauge System Tester 021-00055

The required test equipment consists of a Rotunda Instrument Gauge System Tester 021-00055 or equivalent, a pair of 22 ohm and 145 ohm resistors or another fuel sender of known quality.

If test is performed with the resistors: Disconnect the wiring connector at the sender unit, connect the resistor between the gauge lead and a suitable ground, and turn ignition switch to the ON position. With the 145 ohm resistor, the gauge pointer should contact the FULL mark at minimum edge of pointer to edge of mark. With the 22 ohm resistor, the gauge pointer should contact the EMPTY mark (edge of pointer to edge of mark).

If the test is performed with a fuel sender of known quality, use the following procedure:

1. Turn ignition switch to the OFF position.
2. Disconnect the wiring connector from the sender and connect it to the test sender.
3. Move the float rod away from the fuel tank sender filter against the FULL stop position (approximately 145 ohms). Wait approximately 30 seconds and turn ignition switch to the ON position. The fuel gauge should read on or above the FULL mark.

DIAGNOSIS AND TESTING (Continued)

4. Move the float rod toward the fuel filter against the EMPTY stop position (approximately 22 ohms). Turn ignition switch to the OFF position. Wait approximately 30 seconds and turn ignition to the ON position. The fuel gauge should read on or below the EMPTY mark.
5. If the fuel gauge performs as indicated, perform the fuel sender unit test(s), Pinpoint Test D.
6. If the fuel gauge is out of calibration at the EMPTY mark, or both the EMPTY and FULL mark, replace the gauge.

Sender Unit Connector Pin Locations

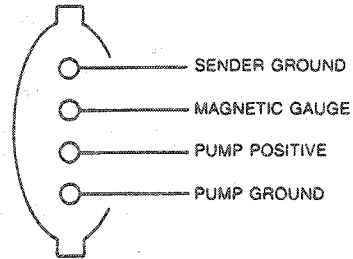

K8948-A

Refer to the following charts for magnetic gauge diagnosis.

**PINPOINT TEST A
FUEL GAUGE INOPERATIVE — POINTER DOES NOT MOVE**

TEST STEP		RESULT	ACTION TO TAKE
A1	VERIFY CONDITION		
	<ul style="list-style-type: none"> ● Verify condition. ● Does pointer move? 	Yes No	GO to D1. GO to A2.
A2	CHECK OTHER GAUGES		
	<ul style="list-style-type: none"> ● Check power to cluster. With ignition ON, observe other gauges and warning indicators for proper operation. If necessary, use Rotunda Digital Volt-Ohmmeter 007-00001 or equivalent or a test lamp to verify voltage at B+ terminal of cluster connector. ● Do gauges and warning indicators operate properly and is voltage present at cluster? 	Yes No	GO to C1. GO to B1.

TK8572C

**PINPOINT TEST B
FUEL GAUGE INOPERATIVE**

TEST STEP		RESULT	ACTION TO TAKE
B1	VERIFY POWER AT FUSE PANEL		
	<ul style="list-style-type: none"> ● Use voltmeter to verify system voltage at load side of warning indicator fuse. ● Is voltage present at load side of fuse? 	Yes No	GO to C1. GO to B2.
B2	VERIFY POWER AT FUSE PANEL		
	<ul style="list-style-type: none"> ● Use voltmeter to verify system voltage at feed side of warning indicator fuse. ● Is voltage present at feed side of fuse? 	Yes No	REPLACE fuse. GO to A1. SERVICE wiring to fuse panel. GO to A1.

TK16216C

**PINPOINT TEST C
CLUSTER DIAGNOSIS**

TEST STEP		RESULT	ACTION TO TAKE
C1	VERIFY POWER AT CLUSTER		
	<ul style="list-style-type: none"> ● Cluster connectors installed. ● Partially remove cluster. ● Check for voltage at cluster connector and gauge terminal. ● Use Rotunda Digital Volt-Ohmmeter 007-00001 or equivalent. ● Is voltage at cluster connector and gauge terminal? 	Yes No	GO to C2. SERVICE circuit. GO to A1.

DIAGNOSIS AND TESTING (Continued)

**PINPOINT TEST C
CLUSTER DIAGNOSIS (Continued)**

TEST STEP		RESULT	ACTION TO TAKE
C2	VERIFY GROUND CIRCUIT AT CLUSTER		
	<ul style="list-style-type: none"> ● Use Rotunda Digital Volt-Ohmmeter 007-00001 or equivalent to check continuity of cluster and gauge ground circuits. ● Is there continuity? 	Yes No	GO to D1. SERVICE circuit. GO to A1.

TK16217B

**PINPOINT TEST D
FUEL GAUGE DIAGNOSIS**

TEST STEP		RESULT	ACTION TO TAKE
D1	CHECK TEST BOX (LOW)		
	<ul style="list-style-type: none"> ● Turn ignition to OFF position. ● Insert Rotunda Instrument Gauge System Tester 021-00055 or equivalent in sender circuit. ● Disconnect 14405 connector under instrument panel and connect tester to cluster side of connector. ● Set tester to 22 ohms. ● Turn ignition to RUN position, wait 60 seconds and read fuel gauge. ● Does gauge read EMPTY? 	Yes No	GO to D4. GO to D2.
D2	CHECK TEST BOX (RETEST)		
	<ul style="list-style-type: none"> ● Turn ignition switch to OFF position. ● Turn ignition switch to RUN position. ● Tap lightly on instrument panel, wait 60 seconds and read fuel gauge. ● Does fuel gauge read EMPTY? 	Yes No	GO to D4. GO to D3.
D3	ANTI-SLOSH MODULE BYPASS TEST		
	<ul style="list-style-type: none"> ● Turn ignition switch to OFF position. ● Remove instrument cluster and inspect flexible circuit. ● Remove anti-slosh module and connect a jumper wire from Gauge Tester directly to fuel gauge 'SIG' terminal. ● Install instrument cluster. ● Turn ignition switch to RUN position and read fuel gauge. ● Does fuel gauge read EMPTY? 	Yes No	REPLACE anti-slosh module. GO to D1. REPLACE fuel gauge. INSTALL anti-slosh module. GO to D1.
D4	CHECK TEST BOX (HIGH)		
	<ul style="list-style-type: none"> ● Turn ignition switch to OFF position. ● With Rotunda Gauge System Tester 021-00055 or equivalent connected as in Step D1, set tester to 145 ohms. ● Turn ignition switch to RUN position. ● Wait 60 seconds and read fuel gauge. ● Does fuel gauge read FULL? 	Yes No	GO to D6. GO to D5.
D5	ANTI-SLOSH MODULE BYPASS TEST		
	<ul style="list-style-type: none"> ● Turn ignition switch to OFF position. ● Remove instrument cluster and inspect flexible circuit. ● Remove anti-slosh module. ● Connect a jumper wire from tester to fuel gauge 'SIG' terminal. ● Turn ignition switch to RUN position and read fuel gauge. ● Does gauge read FULL? 	Yes No	REPLACE anti-slosh module. GO to D1. REPLACE fuel gauge. GO to D1.
D6	INSPECT FUEL TANK		
	<ul style="list-style-type: none"> ● Inspect fuel tank for damage or distortion. ● Is there damage? 	Yes No	REPLACE fuel tank. GO to E1.

TK16218C

DIAGNOSIS AND TESTING (Continued)

PINPOINT TEST E
FUEL SENDER DIAGNOSIS

TEST STEP		RESULT	ACTION TO TAKE
E1	CHECK TEST BOX —EMPTY STOP		
	<ul style="list-style-type: none"> Connect one lead of Digital Volt-Ohmmeter 007-00001 or equivalent to the fuel sender signal lead and the other lead to ground. NOTE: Float rod is against empty stop (closest to filter).	Ohmmeter reads 14-18 ohms Ohmmeter reads less than 14 ohms or greater than 18 ohms	GO to E2. REPLACE fuel sender.
E2	CHECK TEST BOX —FULL STOP		
	<ul style="list-style-type: none"> Connect one lead of Digital Volt-Ohmmeter 007-00001 or equivalent to the fuel sender signal lead and the other lead to sender ground. NOTE: Float rod is against full stop.	Ohmmeter reads 155-165 ohms Ohmmeter reads less than 155 ohms or greater than 165 ohms	GO to E3. REPLACE fuel sender.
E3	CHECK TEST BOX —FLOAT ROD LEVEL		
	<ul style="list-style-type: none"> Connect one lead to Digital Volt-Ohmmeter 007-00001 or equivalent to the fuel sender signal lead and the other lead to sender ground. Slowly move float rod from full stop to empty stop. 	Ohmmeter reading jumps to open condition while decreasing Ohmmeter reading decreases slowly	REPLACE fuel sender. GO to E4.
E4	FUEL SENDER INSPECTION		
	<ul style="list-style-type: none"> Inspect fuel sender. Inspect float and float rod. 	Float rod is distorted Float is badly distorted/damaged hitting the filter	REPLACE sender. REPLACE sender. GO to E5.
E5	CHECK HARNESS CONNECTOR —EMPTY STOP		
	<ul style="list-style-type: none"> Attach all fuel indication connectors. Move float rod to EMPTY STOP position. Turn ignition to RUN position. Wait 60 seconds. Read fuel gauge. Does fuel gauge read EMPTY? 	Yes No	GO to E6. GO to A1.
E6	CHECK HARNESS CONNECTOR —FULL STOP		
	<ul style="list-style-type: none"> Attach all fuel indication connectors. Move float rod to FULL STOP position. Turn ignition to RUN position. Wait 60 seconds. Read fuel gauge. Does fuel gauge read FULL? 	Yes No	Fuel sender OK. GO to A1.

TK13201E

NOTE: Low fuel warning feature is only in instrument clusters with a tachometer.

PINPOINT TEST F
LOW FUEL INDICATOR STAYS ON CONTINUALLY—MORE THAN 1/4 TANK OF FUEL

TEST STEP		RESULT	ACTION TO TAKE
F1	VERIFY CONDITION		
	<ul style="list-style-type: none"> Verify condition. 	Indicator stays on with more than 1/4 tank showing on gauge	GO to F2.

DIAGNOSIS AND TESTING (Continued)

PINPOINT TEST F
LOW FUEL INDICATOR STAYS ON CONTINUALLY—MORE THAN 1/4 TANK OF FUEL (Continued)

TEST STEP		RESULT	ACTION TO TAKE
F2	CHECK ELFW MODULE		
	<ul style="list-style-type: none"> ● Turn ignition to the OFF position. ● Disconnect Circuit 14405 connector under instrument panel and connect a 56 ohm resistor between fuel sender feed to gauge and ground. ● Turn ignition to the RUN position. ● Wait two minutes. 	Indicator off, Gauge at approximately 1/4 Indicator on	GO to F3. INSPECT instrument cluster flexible circuit. REPLACE ELFW / Anti-Slosh module at instrument cluster.
F3	CHECK GAUGE AND INDICATOR		
	<ul style="list-style-type: none"> ● Turn ignition to the OFF position. ● Replace the resistor from test F2 with a 33 ohm resistor. ● Turn ignition to the RUN position. ● Wait two minutes. 	Indicator off Indicator on. Gauge pointer indicator at 1/4 tank or above Indicator on. Gauge indicates approximately 1/8 tank	GO to G3. GO to A1. ELFW / Anti-Slosh module operating properly.

TK16101B

PINPOINT TEST G
INDICATOR STAYS OFF CONTINUALLY

TEST STEP		RESULT	ACTION TO TAKE
G1	VERIFY CONDITION		
	<ul style="list-style-type: none"> ● Verify condition. 	Indicator stays off	GO to G2.
G2	CHECK ELFW MODULE		
	<ul style="list-style-type: none"> ● Turn ignition to the OFF position. ● Disconnect circuit 14405 connector under instrument panel and connect a 33 ohm resistor between fuel sender feed to gauge and ground. ● Turn ignition to ON position. ● Wait two minutes, read gauge. 	Indicator off Indicator on, gauge at 1/4 or above Indicator on, gauge at approximately 1/8	GO to G3. GO to A1. Low fuel warning operating properly.
G3	CHECK INDICATOR		
	<ul style="list-style-type: none"> ● With ignition switch in the ON position, ground indicator circuit between indicator and low fuel module. ● Is indicator ON? 	Yes No	REPLACE ELFW / Anti-Slosh module on instrument cluster. CHECK power circuit to lamp. REPLACE lamp.

TK13203B

REMOVAL AND INSTALLATION

WARNING: FUEL SUPPLY LINES WILL REMAIN PRESSURIZED FOR LONG PERIODS OF TIME AFTER ENGINE SHUTDOWN.

This pressure must be relieved before servicing the fuel system. A valve is provided on the fuel injection supply manifold (9F792) assembly for this purpose. Attach EFI and CFI Fuel Pressure Gauge T80L-9974-B to fuel diagnostic valve on fuel injection supply manifold assembly. Pressure in fuel system may now be released.

Fuel Pump and Sender Assembly

Tools Required:

- EFI and CFI Fuel Pressure Gauge T80L-9974-B
- Fuel Tank Sender Wrench T86T-9275-A
- Rotunda Fuel Storage Tanker 034-00002
- Rotunda Fuel Storage Tanker Adapter Hose 034-00012

Removal

1. Place vehicle on hoist. Do not raise.

REMOVAL AND INSTALLATION (Continued)

2. Depressurize fuel system as outlined.
3. Remove fuel from fuel tank using Rotunda Fuel Storage Tanker 034-00002 and Adapter Hose 034-00012 or equivalent.
4. Raise vehicle on hoist. Refer to Section 00-02.
5. Remove fuel tube (9291). Remove fuel tank support strap (9092) nearest front of vehicle. Carefully lower front of fuel tank and disconnect fuel and vent lines and electrical connector. Remove fuel tank to bench.
6. Remove dirt that has accumulated around sending unit so dirt will not enter fuel tank.
7. Turn locking ring counterclockwise using Fuel Tank Sender Wrench T86T-9275-A. Remove fuel pump locking retainer ring (9C385), pump and sending unit assembly.

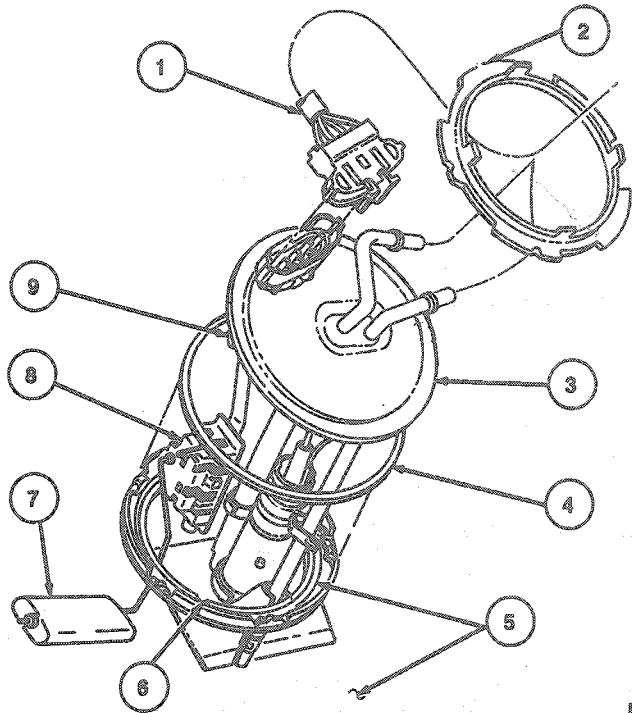
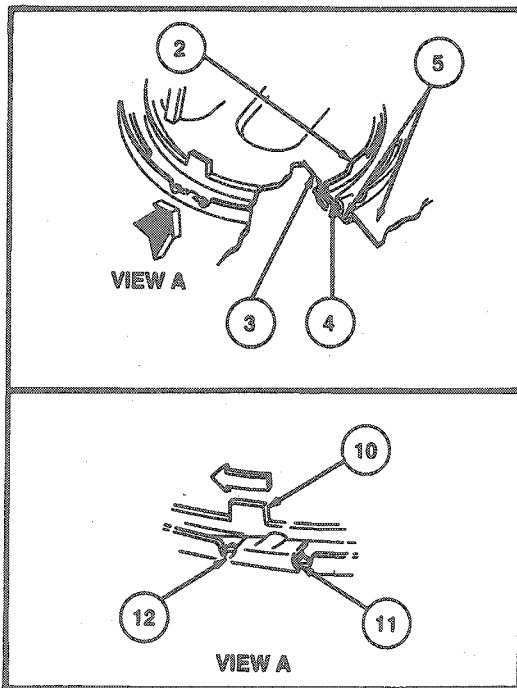

K8945-D

Item	Part Number	Description
1	14405	Wiring Harness Assembly
2	9C385	Locking Ring
3	9H307	Fuel Tank Sending Unit and Pump
4	N803861-S	O-Ring
5	—	Retainer Ring, Part of 9002 Fuel Tank
6	—	Locking Slots

(Continued)

Item	Part Number	Description
7	—	Float, Part of 9H307 Fuel Tank Sending Unit and Pump
8	—	Variable Resistor, Part of 9H307 Fuel Tank Sending Unit and Pump
9	—	Locking Tabs
10	—	Locating Tab
11	—	Stop
12	—	Detent

TK8945D

Installation

1. Clean fuel gauge sending unit mounting surface at fuel tank .

2. Apply a light coating of Premium Long-Life Grease XG-1-C (ESA-M1C75-B) or equivalent on a new seal ring and install seal ring and sending unit assembly. Secure by rotating locking ring clockwise against stop. Ensure seal remains in place.

REMOVAL AND INSTALLATION (Continued)

- Support fuel tank under vehicle and connect fuel and vent lines and electrical connector.
- Install fuel tank. Secure fuel tank support strap.
- Install fuel tube. Fill fuel tank with a minimum of 38 l (10 gal) of fuel.
- Turn ignition switch to ON then OFF at three second intervals (with EFI and CFI Fuel Pressure Gauge T80L-9974-B), until fuel pressure builds to 270 kPa (30 psi).
- Start vehicle, check fuel gauge operation and check for fuel leaks.

- On vehicles with tachometer cluster, install two lower flood lamp bulb and socket assemblies.
- Position mask-and-lens assembly and install eight mask-and-lens retaining screws.
- On vehicles with tachometer cluster, install lower trim panel.
- Install instrument cluster finish panel as outlined in Section 13-01B.

Fuel Gauge**Removal**

- Remove instrument cluster finish panel retaining screws and remove finish panel. Refer to Section 13-01A.
- On vehicles with tachometer cluster, remove lower trim panel retaining screws and remove trim panel.
- Remove eight mask-and-lens mounting screws and remove mask and lens.
- On vehicles with tachometer cluster, remove two lower floodlamp bulb and socket assemblies.
- Lift main dial assembly from backplate.

NOTE: The gauges are mounted to main dial, and some effort may be required to pull quick-connect electrical terminals from clips.

NOTE: Lower flood lamp bulb filters are not secured and may fall out.

- On column shift vehicles only, remove two screws retaining transmission range indicator (PRNDL or PRND 1) to main dial and remove indicator from cluster.
- Manually rotate pointer to align it with slot in dial. Remove mounting screws and carefully pull gauge away from dial, guiding pointer through slot.

Installation

- Carefully position pointer parallel to rectangular raised portion of dial.

CAUTION: The gauges are calibrated at the factory. Excessive rough handling could disturb the calibration.



- Guide the pointer carefully through slot in main dial. Then, position gauge on mounting bosses and install mounting screws. Tighten screws to 0.8-1.4 N·m (8-12 lb-in).
- On column shift vehicles, install transmission range indicator.
- Install main dial assembly to cluster backplate by aligning it on guides. Press carefully and firmly to seat all electrical terminals.

NOTE: Lower flood lamp bulb filters are not secured and may fall out.

Low Fuel Level Warning Switch**Removal and Installation**

- Remove instrument cluster. Refer to Section 13-01B.
- Grasp circuit board on outside far edges. Avoid touching circuit components.
- Push out connector tab and slide low fuel level warning switch (9F326) out.
- To install, position low fuel level warning switch in guides, line up terminals over center of flex circuit connections, and push low fuel level warning switch until it clicks in place.
- Install instrument cluster. Refer to Section 13-01B.

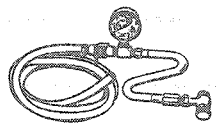
SPECIAL SERVICE TOOLS

Tool Number / Description	Illustration
T80L-9974-B EFI and CFI Fuel Pressure Gauge	 T80L-9974-B
T86T-9275-A Fuel Tank Sender Wrench	 T86T-9275-A

ROTUNDA EQUIPMENT

Model	Description
007-00001	Digital Volt-Ohmmeter
021-00055	Instrument Gauge System Tester
034-00002	Fuel Storage Tanker
034-00012	Fuel Storage Tanker Adapter Hose

PARTS CROSS-REFERENCE

Base Part #	Part Name	Old Part Name
9002	Fuel Tank	
9092	Fuel Tank Support Strap	
9280	Fuel Gauge	
9291	Fuel Tube	
9A011	Fuel Tank Sender Filter	

(Continued)

Base Part #	Part Name	Old Part Name
9C385	Fuel Pump Locking Retainer Ring	
9F326	Low Fuel Level Warning Switch	
9F792	Fuel Injection Supply Manifold	

SECTION 13-04 Charging System Gauge / Warning Indicator

SUBJECT	PAGE	SUBJECT	PAGE
DESCRIPTION AND OPERATION	13-04-1	REMOVAL AND INSTALLATION	
DIAGNOSIS AND TESTING	13-04-1	Bulb, Indicator	13-04-2
		VEHICLE APPLICATION	13-04-1

VEHICLE APPLICATION

Taurus / Sable with conventional cluster.

DESCRIPTION AND OPERATION

A red generator charge indicator is located in the instrument cluster. This indicator glows when there is no generator output.

When the ignition switch contacts are closed (switch turned on), battery current flows through the charge indicator and the parallel resistor (500 ohm) to the regulator and the indicator comes on.

When the generator builds up enough voltage to energize a circuit in the voltage regulator, the charge indicator goes out.

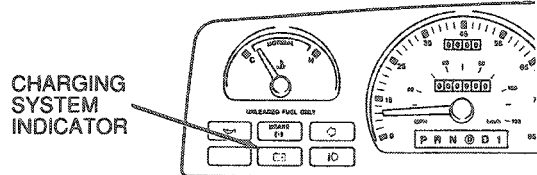

TAURUS

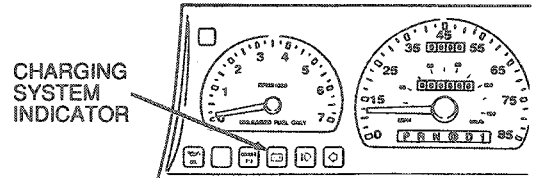

TAURUS SHO AND SABLE K16930-A

DIAGNOSIS AND TESTING

1. If the charge indicator does not come on (key ON, engine OFF), disconnect the wiring plug connector from the regulator. Connect a jumper wire from wiring connector 'I' terminal to the negative battery post cable clamp.

Integral Generator Regulator (IGR)

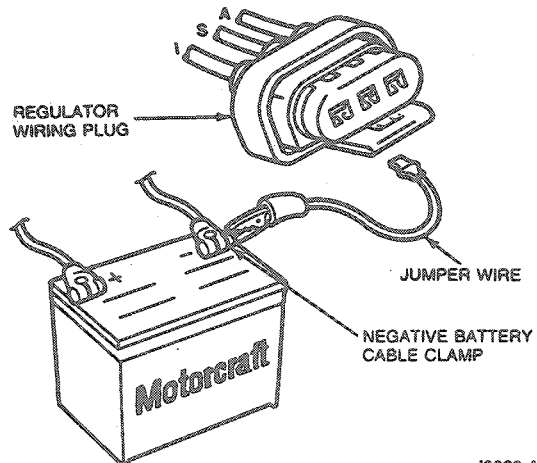

J3068-A

DIAGNOSIS AND TESTING (Continued)

2. Turn ignition to RUN position with engine off. If indicator does not light, check for presence of bulb socket. If bulb is present, check for contact of bulb socket leads to the flexible printed circuit. If good, check indicator bulb for continuity and replace bulb if burned out. If bulb checks good, check wiring from regulator to bulb socket and bulb socket to battery (through ignition switch) for opens or shorts.
3. If indicator does light, remove jumper wire and reconnect wiring plug to regulator.

NOTE: Refer to Section 14-02 for complete charging system diagnosis.

REMOVAL AND INSTALLATION

On some vehicles it is necessary to remove instrument cluster to gain access to the indicator bulb. Refer to Section 13-01B.

Bulb, Indicator**Removal and Installation**

To remove indicator bulb, turn bulb and socket assembly one-quarter turn counterclockwise and remove. To install, position new bulb and socket assembly to printed circuit and turn it clockwise one-quarter turn.

SECTION 13-05 Tachometer, Oil Pressure, Coolant Temperature Gauges / Warning Indicators

SUBJECT	PAGE	SUBJECT	PAGE
DESCRIPTION AND OPERATION		REMOVAL AND INSTALLATION	
Magnetic Temperature Gauge.....	13-05-2	Coolant Temperature Sending Unit	13-05-8
Oil Pressure Indicator	13-05-2	Indicator Bulb	13-05-8
Tachometer	13-05-1	Oil Pressure Engine Unit Gauge.....	13-05-6
DIAGNOSIS AND TESTING		Tachometer	13-05-6
Engine Oil Pressure	13-05-3	SPECIAL SERVICE TOOLS	
Oil Pressure Indicator	13-05-3	SPECIAL SERVICE TOOLS	
PARTS CROSS-REFERENCE		SPECIAL SERVICE TOOLS	
PARTS CROSS-REFERENCE		13-05-8	
		VEHICLE APPLICATION	
		VEHICLE APPLICATION	
		13-05-1	

VEHICLE APPLICATION

Taurus / Sable.

DESCRIPTION AND OPERATION

The tachometer, gauge and warning indicator systems covered in this section are for conventional clusters only. For electronic instrument cluster applications, refer to Section 13-01A.

Tachometer

The tachometer is an electrically-operated instrument which indicates engine speed in revolutions per minute (rpm). The tachometer range is 0 to 7000 rpm, except Taurus SHO models which have a range of 0 to 8000 rpm.

The tachometer is mounted in the instrument cluster assembly. The schematic wiring diagram shows the tachometer system.

DESCRIPTION AND OPERATION (Continued)

Wiring Diagrams

See EVTM for more details of this circuit

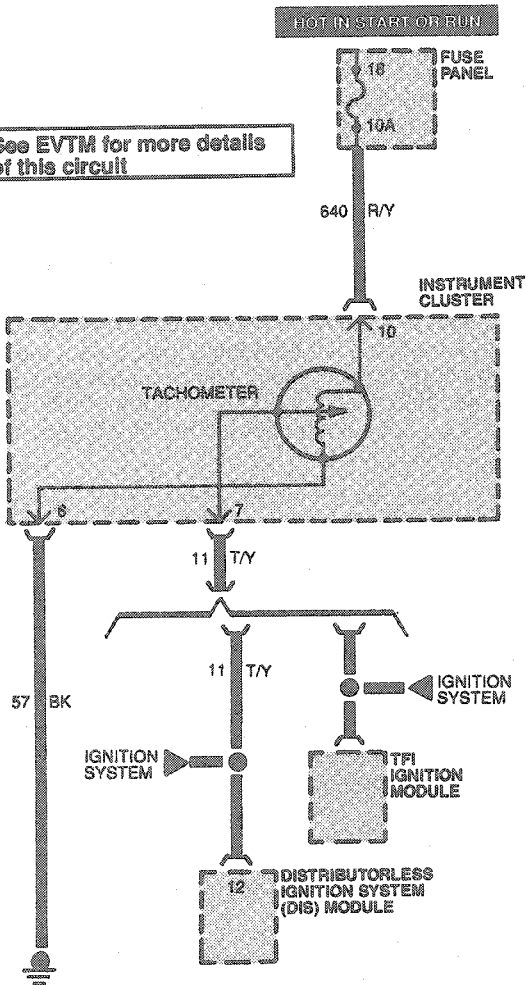

K17522-A

Oil Pressure Indicator

A red warning indicator glows when the oil pressure is below a prescribed value. The indicator should come on when the ignition switch is first turned to the RUN position. The indicator should go out within a few seconds after the engine starts, signaling that the oil pressure is OK.

The oil switch is installed into a fitting in the engine block. The switch is calibrated to close between 26-44 kPa (4.5-7.5 psi).

The indicator is connected between the oil pressure switch unit (mounted on the engine) and the coil terminal of the ignition switch.

HOT IN START OR RUN

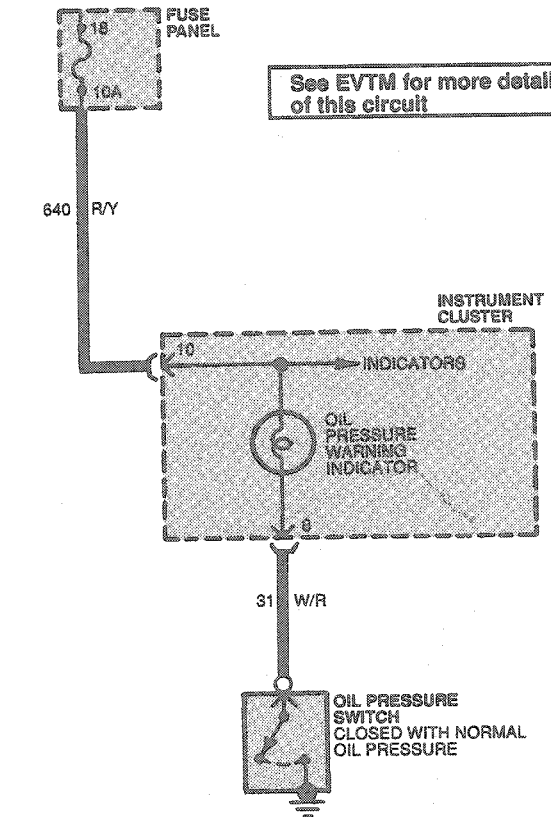

See EVTM for more details of this circuit

K17524-A

Magnetic Temperature Gauge

The magnetic temperature gauge movement consists of three primary coils, one of which is wound at a 90 degree angle to the other two. The coils form a magnetic field which varies in direction according to the variable resistance of the sender unit which is connected between two of them. A primary magnet, to which a shaft and pointer are attached, rotates to align to this primary field, resulting in pointer position. The bobbin / coil assembly is pressed into a metal housing which has two holes for dial mounting. There is no adjustment, calibration or maintenance required for these gauges.

NOTE: An instrument voltage regulator (IVR) is not required for this system.

DESCRIPTION AND OPERATION (Continued)

CAUTION: Do not remove pointers; they cannot be recalibrated.

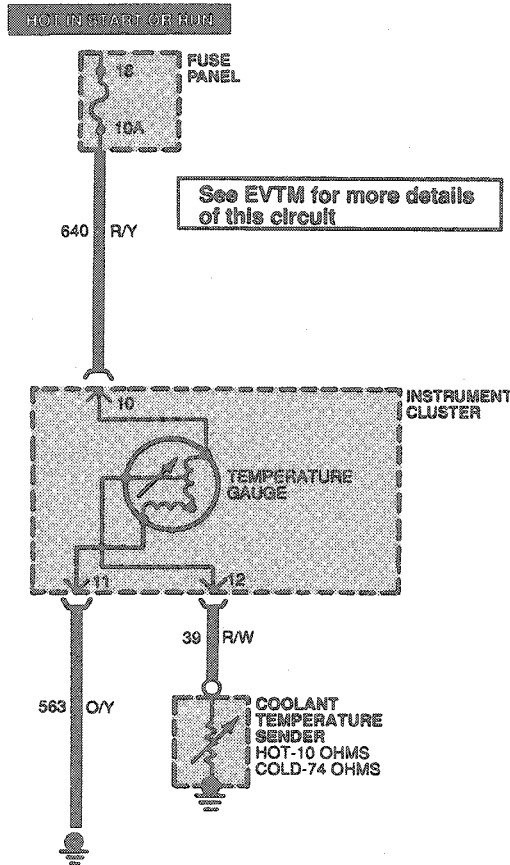

Disconnect the temperature switch wire before testing the oil pressure indicating system on those vehicles that have an engine warning indicator.

To test the oil pressure switch and indicator, turn the ignition switch to RUN but do not start the engine. The indicator should come on. If the indicator does not come on, remove the wire from the switch terminal and connect the wire to ground. If the indicator now comes on, the oil pressure switch is inoperative. Replace the switch. If the indicator does not come on with the switch wire connected to ground, the warning indicator is burned out or the system wiring is open-circuited. Replace the indicator or service the wiring.

If the indicator stays on with the engine running and the engine has adequate oil pressure, disconnect the wire from the oil pressure switch. The indicator should go out. If indicator goes out, replace switch. If indicator does not go out, service shorted wiring between switch and indicator.

Engine Oil Pressure

Tools Required:

- Oil Pressure Gauge T73L-6600-A

3.8L Engine

NOTE: To check engine oil pressure, a piece of 1/4 inch pipe, 5 1/2 inches long and a 90 degree 1/4 inch pipe elbow will be needed. These must have 1/4-18 NPTF threads.

1. Remove oil pressure switch as outlined.
2. Install pipe and elbow assembly as a unit into sender fitting.
3. Install Oil Pressure Gauge T73L-6600-A to pipe elbow.
4. Run engine to normal operating temperature and read pressure gauge. Gauge should read a minimum of 62 kPa (9 psi) at hot idle.
5. Remove gauge and pipe assembly.
6. Install oil pressure switch as outlined.

DIAGNOSIS AND TESTING

Oil Pressure Indicator

To test the indicator, turn the ignition switch to RUN. Do not start the engine. The indicator should come on. Start the engine. The indicator should go out, signaling that the oil pressure is OK.

DIAGNOSIS AND TESTING (Continued)

PINPOINT TEST A: TACHOMETER INOPERATIVE, ERRATIC, WRONG INDICATION

TEST STEP		RESULT	ACTION TO TAKE
A1	CHECK OPERATION	Inoperative Erratic or wrong indication	GO to A2.
	<ul style="list-style-type: none"> ● Check tachometer operation. 		GO to A3.
A2	CHECK FUSE	Yes No	GO to A3.
	<ul style="list-style-type: none"> ● Check tachometer fuse. ● Is fuse OK? 		REPLACE fuse.
A3	CHECK WIRING	Yes No	GO to A4.
	<ul style="list-style-type: none"> ● Check for loose wiring connections in engine compartment and at instrument cluster. ● Are all connections OK? 		SECURE loose connections.
A4	CHECK RESISTANCE AND VOLTAGE	Yes No	GO to A5.
	<ul style="list-style-type: none"> ● Disconnect battery. ● Remove instrument cluster and make resistance and voltage checks at 14401 wire harness connector as follows (refer to pin locations below): <ul style="list-style-type: none"> — Check Pins 6 and 11 resistance to chassis ground—should read 1 ohm or less. — For Taurus / Sable check Pin 7 resistance to negative terminal of ignition coil should be 1 ohm or less. — For Taurus SHO models check Pin 7 resistance to Pin 6 of DIS module. Should be 1 ohm or less. — Connect battery. Turn ignition switch ON. Check for + 12V at Pin 10. Turn ignition switch OFF. Disconnect battery. 		Condition is not in tachometer. SERVICE wiring.
<p>14401 HARNESS CONNECTOR TO INSTRUMENT CLUSTER AS VIEWED FROM REAR OF HARNESS K19356-A</p>			
A5	CHECK CONNECTOR CLIPS	Yes No	REPLACE tachometer.
	<ul style="list-style-type: none"> ● Check for loose tachometer connector clips on rear of instrument cluster, or damaged printed circuit. ● Are connector clips OK? 		TIGHTEN or REPLACE clips. REPLACE printed circuit.

TK16970B

DIAGNOSIS AND TESTING (Continued)

**PINPOINT TEST B
TEMPERATURE GAUGE INOPERATIVE — POINTER DOES NOT MOVE**

TEST STEP		RESULT	ACTION TO TAKE
B1	VERIFY CONDITION		
	<ul style="list-style-type: none"> Observe gauge performance. Does gauge pointer move? 	Yes No	GO to C1 for temperature gauge. GO to B2.
B2	VERIFY CLUSTER PERFORMANCE		
	<ul style="list-style-type: none"> With the ignition ON, observe the other gauges and warning indicators for proper operation. Do other gauges and warning indicators operate properly? 	Yes No	GO to D1. GO to C1.

TK16967B

**PINPOINT TEST C
TEMPERATURE GAUGE INOPERATIVE**

TEST STEP		RESULT	ACTION TO TAKE
C1	VERIFY POWER AT FUSE PANEL		
	<ul style="list-style-type: none"> Using Rotunda Digital Volt-Ohmmeter 007-00001 or equivalent verify system voltage at load side of warning indicator fuse. Is system voltage present at load side of fuse? 	Yes No	GO to D1. GO to C2.
C2	VERIFY POWER AT FUSE PANEL		
	<ul style="list-style-type: none"> Using Rotunda Digital Volt-Ohmmeter 007-00001 or equivalent verify system voltage at feed side of warning indicator fuse. Is system voltage present at feed side of fuse? 	Yes No	REPLACE fuse. GO to B1. SERVICE wiring to fuse panel. GO to B1.

TK16972B

**PINPOINT TEST D
TEMPERATURE GAUGE INOPERATIVE**

TEST STEP		RESULT	ACTION TO TAKE
D1	VERIFY POWER AT CLUSTER		
	<ul style="list-style-type: none"> Partially remove cluster from IP. Using Rotunda Digital Volt-Ohmmeter 007-00001 or equivalent verify system voltage at cluster connector and/or gauge terminal. Inspect cluster connector for damage. Is system voltage present at cluster connector and/or gauge terminal? 	Yes No	GO to D2. SERVICE as required. GO to B1.
D2	VERIFY GROUND CIRCUITRY AT CLUSTER		
	<ul style="list-style-type: none"> Using Rotunda Digital Volt-Ohmmeter 007-00001 or equivalent check continuity of cluster and gauge ground circuitry. Is ground circuitry OK? 	Yes No	GO to E1 for temperature gauge. SERVICE as required. GO to B1.

TK17129A

**PINPOINT TEST E
TEMPERATURE GAUGE INACCURATE**

TEST STEP		RESULT	ACTION TO TAKE
E1	TEST SENDER CIRCUIT AT LOW		
	<ul style="list-style-type: none"> Insert Rotunda Instrument Gauge, System Tester 021-00055 or equivalent. Disconnect connector at sender and connect tester to cluster side of connector. Set to 74 ohms. Does gauge read 'C'? 	Yes No	GO to E2. GO to E3.
E2	TEST SENDER CIRCUIT AT HIGH		
	<ul style="list-style-type: none"> Set Gauge System Tester to 10 ohms. Does gauge read 'H'? 	Yes No	REPLACE sender. GO to E3.

DIAGNOSIS AND TESTING (Continued)

PINPOINT TEST E
TEMPERATURE GAUGE INACCURATE (Continued)

TEST STEP		RESULT	ACTION TO TAKE
E3	CHECK SENDER CIRCUIT WIRING		
	<ul style="list-style-type: none"> ● Check sender circuit wiring and cluster flex circuit for shorts or opens with Rotunda Digital Volt-Ohmmeter 007-00001 or equivalent. ● Is wiring OK? 	Yes No	REPLACE gauge. SERVICE wiring / flex circuit. GO to B1.

TK16968A

REMOVAL AND INSTALLATION

Tachometer**Removal**

1. Disconnect battery ground cable.
2. Remove and disassemble instrument cluster. Refer to Section 13-01B.
3. Remove tachometer from gauge clips by pulling tachometer from backplate.

Installation

1. Carefully position tachometer over gauge clips.
CAUTION: Tachometer is calibrated at factory. Excessive rough handling could disturb calibration.
2. Press tachometer into gauge clips in backplate. Use care not to get fingerprints on applique.
3. Assemble and install instrument cluster. Refer to Section 13-01B.
4. Connect battery ground cable. Check tachometer operation.

Oil Pressure Engine Unit Gauge**Except 3.8L Engine****Tools Required:**

- Removal/Replacer Tool T87L-9278-A

Removal and Installation

1. Disconnect wire at oil pressure sender (9278) and remove switch using Removal/Replacer Tool T87L-9278-A.
2. To install oil pressure sender coat threads with Pipe Sealant with Teflon® D8AZ-19554-A (ESG-M4G 194, ESR-M18P7-A) or equivalent and install fitting.
3. Tighten oil pressure sender to 16-22 N·m (12-16 lb-ft) using Removal/Replacer Tool T87L-9278-A or equivalent. The 3.0L and 3.2L SHO oil oil pressure sender torque is 12-16 N·m (9-11 lb-ft).

4. Install electrical connector to oil pressure sender.
5. Start engine and check for oil leaks.

3.8L Engine**Tools Required:**

- Removal/Replacer Tool T87L-9278-A

Removal

1. Remove washer solvent / coolant recovery reservoir.
2. Release drive belt tension and position drive belt aside.
3. Remove belt idler pulley below power steering pump.
4. Disconnect wire from oil pressure sender and remove oil pressure sender using Removal/Replacer Tool T87L-9278-A.

Installation

1. Apply Pipe Sealant with Teflon® D8AZ-19554-A (ESG-M4G 194, ESR-M18P7-A) or equivalent to threads of oil pressure sender. Install oil pressure sender using Removal/Replacer Tool T87L-9278-A or equivalent. Tighten to 11-24 N·m (9-17 lb-ft).
2. Install idler pulley. Tighten bolt to 70-95 N·m (52-70 lb-ft).
3. Install drive belt.
4. Install washer solvent / coolant recovery reservoir. Top off fluids.
5. Start engine and check for leaks.

The pressure switch-type unit used with the warning indicator system is **not** interchangeable with the variable resistance-type unit used with the gauge system. Refer to the Master Parts catalog for proper parts usage.

CAUTION: Installation of the wrong part will result in an inoperative oil pressure indicating system and a damaged sender unit or gauge.

REMOVAL AND INSTALLATION (Continued)

3.0L MFI Engine

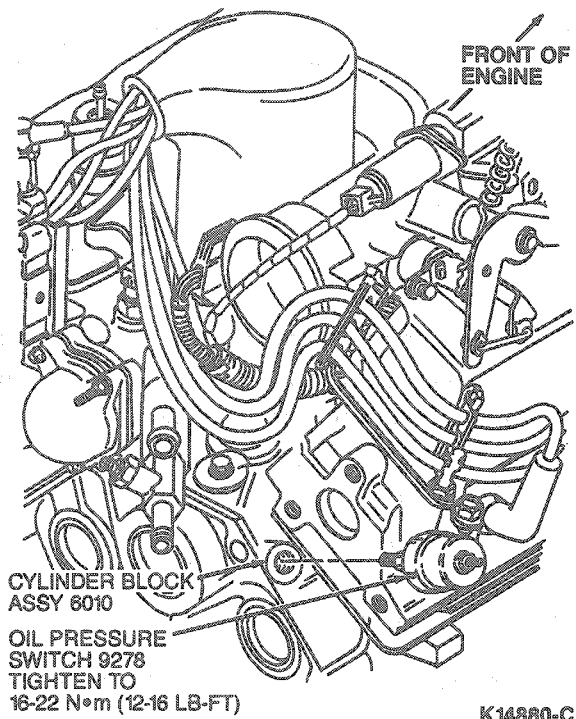

3.0L and 3.2L SHO Engine

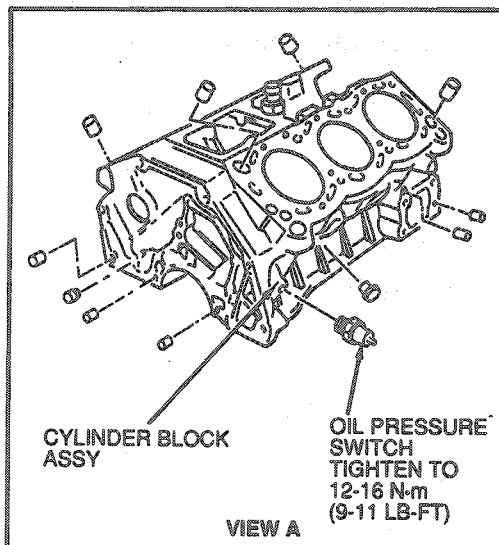
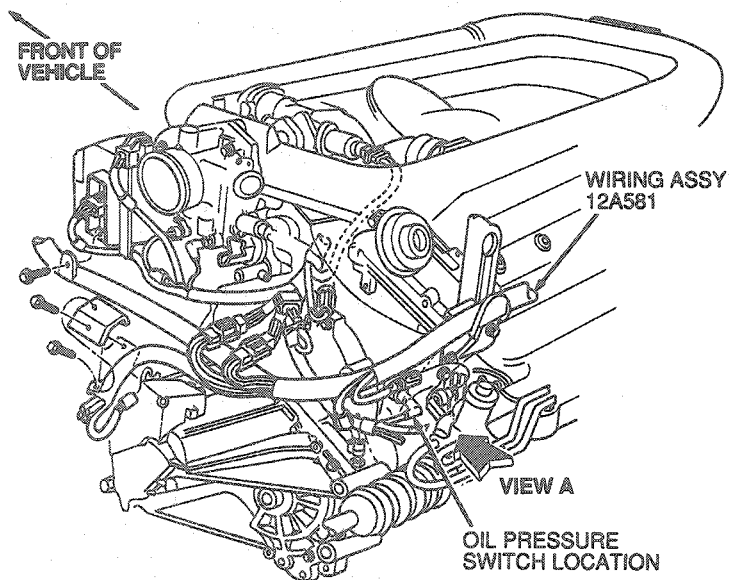

K14881-B

REMOVAL AND INSTALLATION (Continued)

3.8L MFI Engine

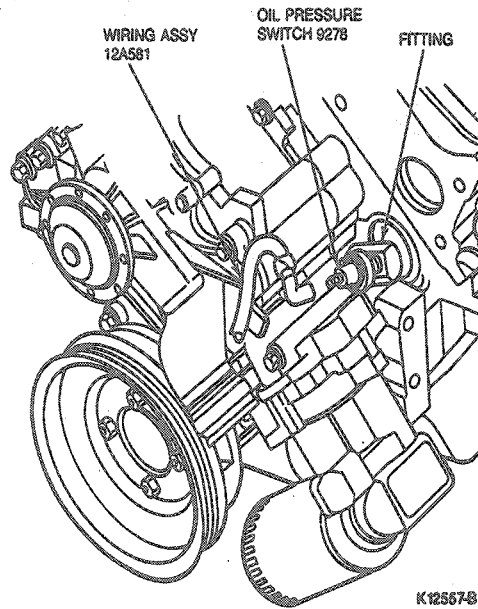

2. Install sending unit. Tighten to 16-24 N·m (12-17 lb-ft).
3. Connect electrical connector to sending unit.
4. Fill and bleed cooling system.
5. Connect negative battery terminal.
6. Start engine and check for coolant leaks.

3.0L MFI Engine

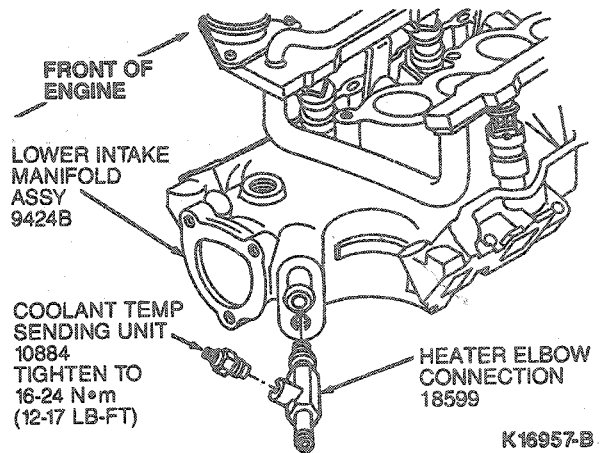

Coolant Temperature Sending Unit

3.0L Engine

CAUTION: Misuse of the sending units will result in inoperative temperature indicating system.

Removal

1. Disconnect negative battery terminal.
WARNING: NEVER REMOVE THE RADIATOR CAP UNDER ANY CIRCUMSTANCES WHILE THE ENGINE IS OPERATING. FAILURE TO FOLLOW THESE INSTRUCTIONS COULD RESULT IN SERIOUS PERSONAL INJURY FROM HOT COOLANT OR STEAM BLOW OUT (AND/OR DAMAGE TO THE COOLING SYSTEM OR ENGINE). SWITCH OFF THE ENGINE AND WAIT UNTIL IT HAS COOLED. EVEN THEN, USE EXTREME CARE WHEN REMOVING THE CAP FROM A HOT RADIATOR. WRAP A THICK CLOTH AROUND THE CAP AND TURN IT SLOWLY TO THE FIRST STOP. STEP BACK WHILE THE PRESSURE IS RELEASED FROM THE COOLING SYSTEM. WHEN CERTAIN ALL THE PRESSURE HAS BEEN RELEASED, PRESS DOWN ON THE CAP WITH A CLOTH, TURN AND REMOVE IT.

2. Drain engine cooling system.
3. Disconnect electrical connector to sending unit.
4. Loosen and remove sending unit.

Installation

1. Apply teflon tape or Pipe sealant with Teflon® D8AZ-19554-A (ESG-M4G194-A) or equivalent to threads of sending unit.

Indicator Bulb

Removal and Installation

It is necessary to remove the instrument cluster to gain access to the indicator bulb. Refer to Section 13-01B.



To remove the indicator bulb, turn the bulb and socket assembly one-quarter turn counterclockwise and remove. To install, position the new bulb and socket assembly to the printed circuit and turn it clockwise one-quarter turn.

SPECIFICATIONS

TORQUE SPECIFICATIONS

Description	N·m	Lb·Ft
Oil Pressure Switch (3.0L)	16-22	12-16
Oil Pressure Switch (3.0L / 3.2L SHO)	12-16	9-11
Oil Pressure Switch (3.8L)	11-24	9-17
Coolant Temperature Sending Unit	16-24	12-17
Idle Pulley Bolt	70-95	52-70

SPECIAL SERVICE TOOLS

Tool Number/ Description	Illustration
T73L-6800-A Oil Pressure Gauge	 <p style="text-align: center;">T73L-6800-A</p>
T87L-9278-A Removal/ Replacer Tool	 <p style="text-align: center;">T87L-9278-A</p>

ROTUNDA EQUIPMENT	
Model	Description
007-00001	Digital Volt-Ohmmeter
021-00055	Instrument Gauge System Tester

PARTS CROSS-REFERENCE

Base Part #	Part Name	Old Part Name
9278	Oil Pressure Sender	