

SECTION 13-01B Instrument Cluster—Conventional

SUBJECT	PAGE	SUBJECT	PAGE
DESCRIPTION AND OPERATION		REMOVAL AND INSTALLATION	
Instrument Cluster	13-01B-1	Bulb, Illumination	13-01B-6
Magnetic Gauges	13-01B-3	Flexible Printed Circuit	13-01B-6
DIAGNOSIS AND TESTING		Instrument Cluster	13-01B-4
Gauges	13-01B-3	Low Fuel Warning Assembly, Electronic	13-01B-6
Printed Circuit	13-01B-3	SPECIFICATIONS	13-01B-6
		VEHICLE APPLICATION	13-01B-1

VEHICLE APPLICATION

Taurus/Sable.

DESCRIPTION AND OPERATION

Instrument Cluster

Taurus

The standard instrument cluster contains a speedometer, fuel gauge, temperature gauge, odometer, and trip odometer. It also contains high beam, fasten safety belts, brake, charge and oil pressure warning indicators. The optional Sable instrument cluster is supplied with the Taurus vehicle when diagnostic warning indicators are ordered (Standard on LX).

Taurus—Standard

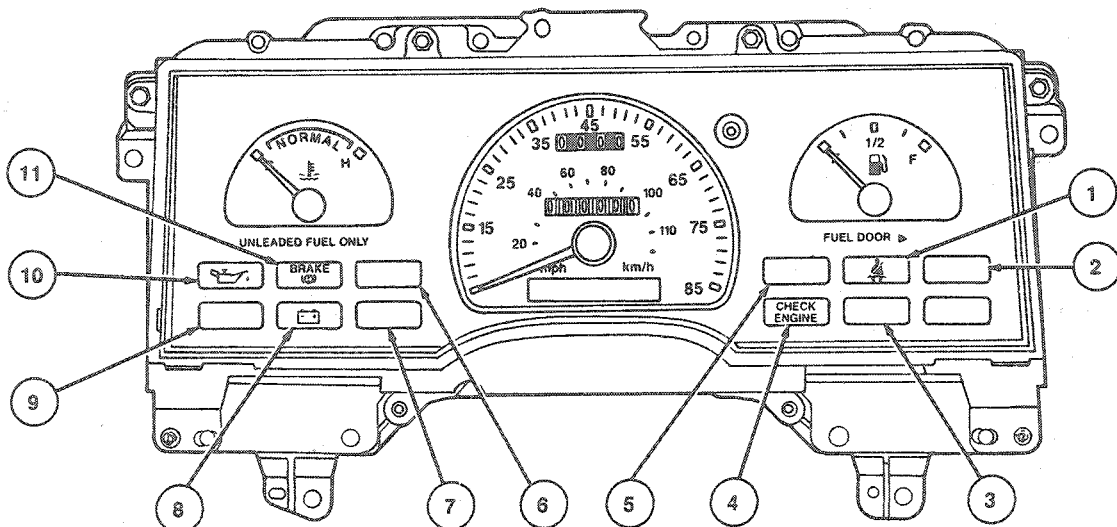

K13972-B

DESCRIPTION AND OPERATION (Continued)

Item	Description
1	Safety Belt Indicator
2	Liftgate Ajar Indicator
3	Air Bag Readiness Indicator
4	Check Engine / Malfunction Indicator Lamp (MIL)
5	RH Turn Signal Indicator

Item	Description
6	LH Turn Signal Indicator
7	High Beam Indicator
8	Charging System Indicator
9	Anti-Lock Brake Indicator
10	Low Oil Pressure Indicator
11	Brake System Indicator

(Continued)

TK13972B

Sable

The Sable instrument cluster contains a speedometer with trip odometer, fuel gauge, temperature gauge and tachometer. The cluster also contains a high beam, turn signals, fasten safety belts, brake, oil pressure, liftgate ajar (station wagon only) and charge warning indicators. An optional cluster with diagnostic warning indicators is also available (standard on LS).

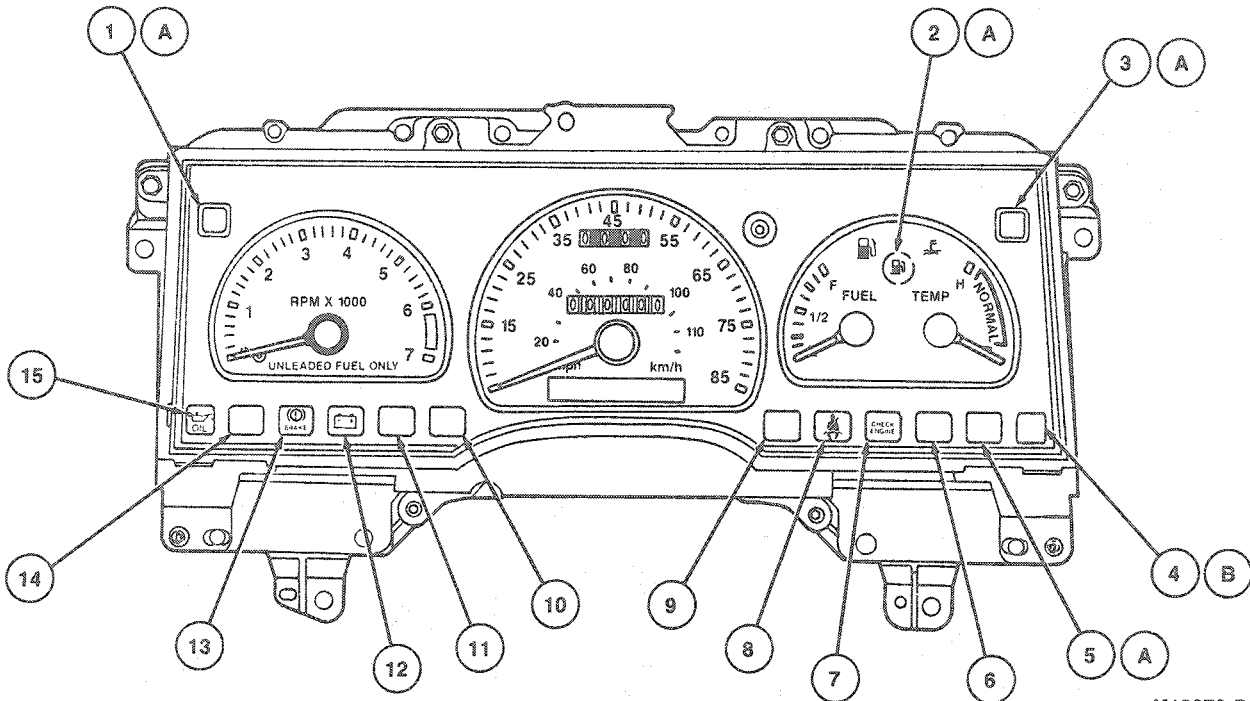
Sable LS/Taurus LX (Standard) Sable/Taurus (Optional)

K13973-B

Item	Description
1A	Lamp Out
2A	Low Fuel Indicator
3A	Low Washer Fluid Indicator
4B	Liftgate/Door Ajar Indicator
5A	Check Oil Indicator
6	Air Bag Readiness Indicator
7	Check Engine Indicator
8	Safety Belt Indicator

Item	Description
9	RH Turn Signal Indicator
10	LH Turn Signal Indicator
11	High Beam Indicator
12	Charging System (Amp) Indicator
13	Brake Warning Indicator
14	Anti-Lock Brake Indicator
15	Low Oil Pressure Indicator
A	Not Included on Sable Standard Cluster
B	Standard on Station Wagon

(Continued)

DESCRIPTION AND OPERATION (Continued)

Taurus SHO

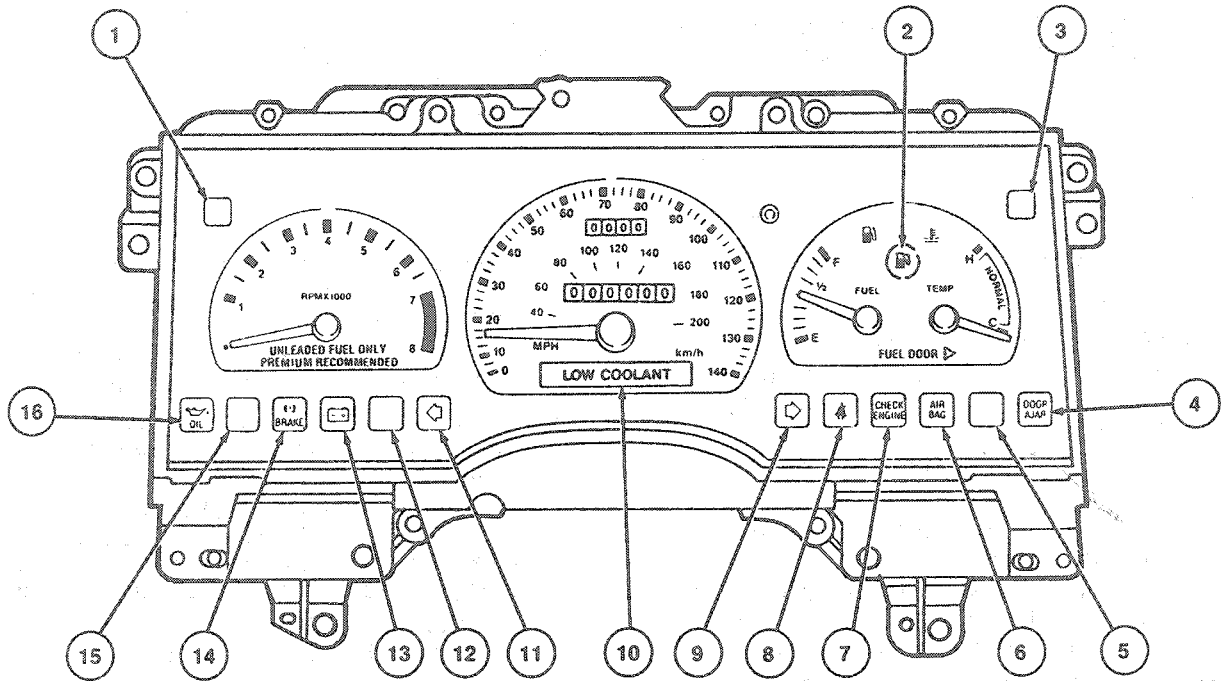

K17130-A

Item	Description
1	Lamp Out
2	Low Fuel Indicator
3	Low Washer Fluid Indicator
4	Liftgate /Door Ajar Indicator
5	Check Oil Indicator
6	Air Bag Readiness Indicator
7	Malfunction Indicator

(Continued)

Item	Description
8	Safety Belt Indicator
9	RH Turn Signal Indicator
10	Low Coolant Indicator
11	LH Turn Signal Indicator
12	High Beam Indicator
13	Charging System (Amp) Indicator
14	Brake Warning Indicator
15	Anti-Lock Brake Indicator
16	Low Oil Pressure Indicator

Magnetic Gauges

CAUTION: Do not remove magnetic gauge pointers; the gauge cannot be recalibrated.

NOTE: An instrument voltage regulator (IVR) is not required for this system.

DIAGNOSIS AND TESTING

Printed Circuit

The printed circuit which supplies current to the instrument panel indicators, gauges, and some clocks, is made of copper foil which is bonded to a polyester base film (usually referred to as Mylar).

The printed circuit is mounted to the cluster housing and due to its location, cannot be easily inspected and/or tested in the vehicle. This makes the printed circuit vulnerable to damage when a probe is used for in-vehicle testing as the probe can pierce the printed circuit or in some cases, burn the copper conductor.

Since there is no approved procedure for in-vehicle testing of the printed circuit, it must be removed for visual inspection. If no visual damage is evident, each circuit should be tested with an ohmmeter. If an open circuit or short is detected, the printed circuit must be replaced.

Gauges

Refer to Section 13-02 for diagnosis and removal and installation of the speedometer or odometer.

DIAGNOSIS AND TESTING (Continued)

Refer to Section 13-03 for diagnosis and removal and installation of the fuel gauge.

Refer to Section 13-04 for diagnosis and removal and installation of the charging system gauge or warning indicator.

Refer to Section 13-05 for diagnosis and removal and installation of the tachometer, oil pressure, coolant temperature gauges or warning indicators.

Refer to Section 13-09 for diagnosis and removal and installation of miscellaneous gauges or warning devices.

REMOVAL AND INSTALLATION

Instrument Cluster

Removal and Installation

1. Disconnect battery ground cable.
2. Remove ignition lock cylinder assembly (refer to Section 11-04) to permit removal of steering column shrouds.
3. Remove steering column trim shrouds.
4. Remove screws retaining lower LH and radio finish panels (one screw each) and remove panels by snapping out.
5. On Taurus vehicles only, remove clock assembly (or clock cover) to gain access to finish panel screw behind clock. Refer to Section 13-07.
6. Remove seven cluster opening finish panel retaining screws, and one jam nut behind headlamp switch. Remove finish panel by rocking upper edge toward driver.
7. On column shift vehicles only, disconnect transaxle range indicator cable from column (one screw and cable loop).
8. Disconnect upper speedometer cable from lower speedometer cable in engine compartment.
9. Remove four screws retaining cluster to instrument panel and pull cluster assembly forward.
10. Disconnect cluster electrical connectors and speedometer cable. Press cable latch to disengage cable from speedometer head, while pulling cable away from cluster. Remove cluster.
11. To install, reverse Removal procedure and calibrate the transaxle range indicator using the thumbwheel.

Taurus

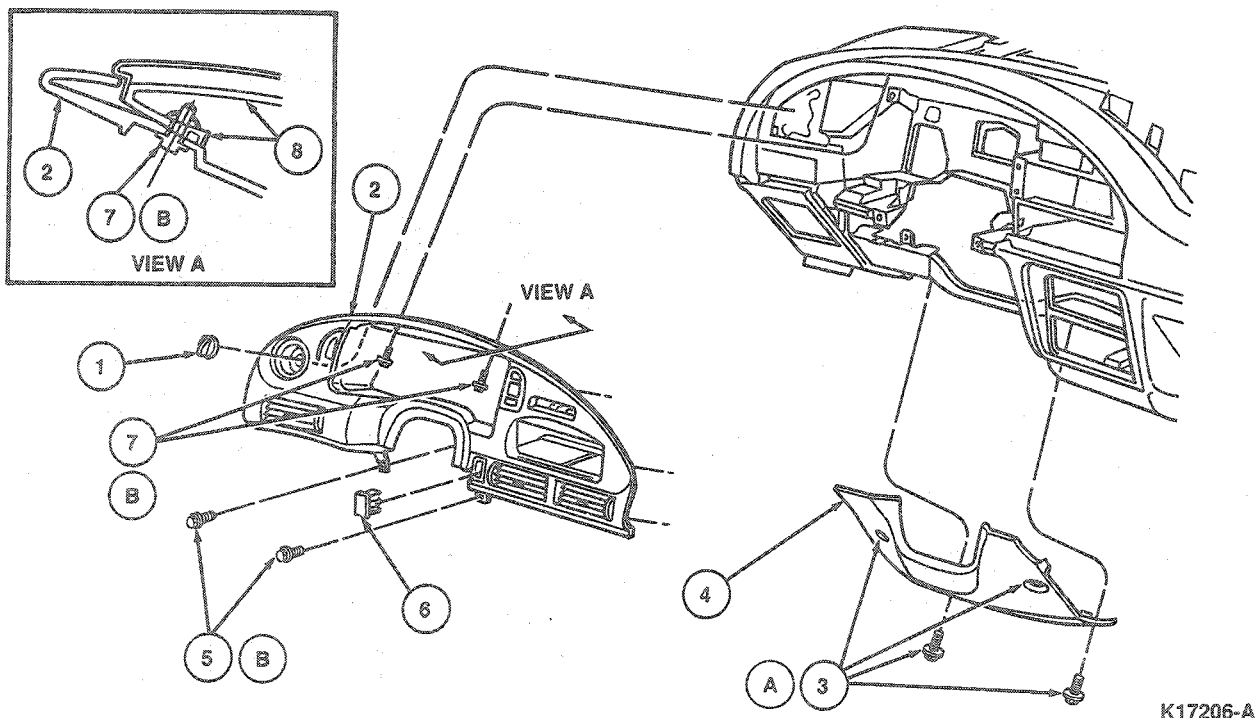

REMOVAL AND INSTALLATION (Continued)

Item	Part Number	Description
1	11666	Lamp Switch Knob Assy
2	044D70	Instrument Panel Cluster Assy
3A	N806715-S36B	Screw (4 Req'd)
4	046A72	Steering Column Opening Cover Assy
5B	N804306-S36B	Lower Instrument Panel Cluster Screws (2 Req'd)

(Continued)

Item	Part Number	Description
6	044F58	Instrument Panel Control Opening Cover Assy
7B	N804306-S36B	Upper Instrument Panel Cluster Screws (2 Req'd)
8	—	Instrument Panel Cover and Pad Assy
A	—	Tighten to 9-14 N·m (80-124 Lb·In)
B	—	Tighten to 2-3 N·m (18-27 Lb·In)

TK17206A

Sable

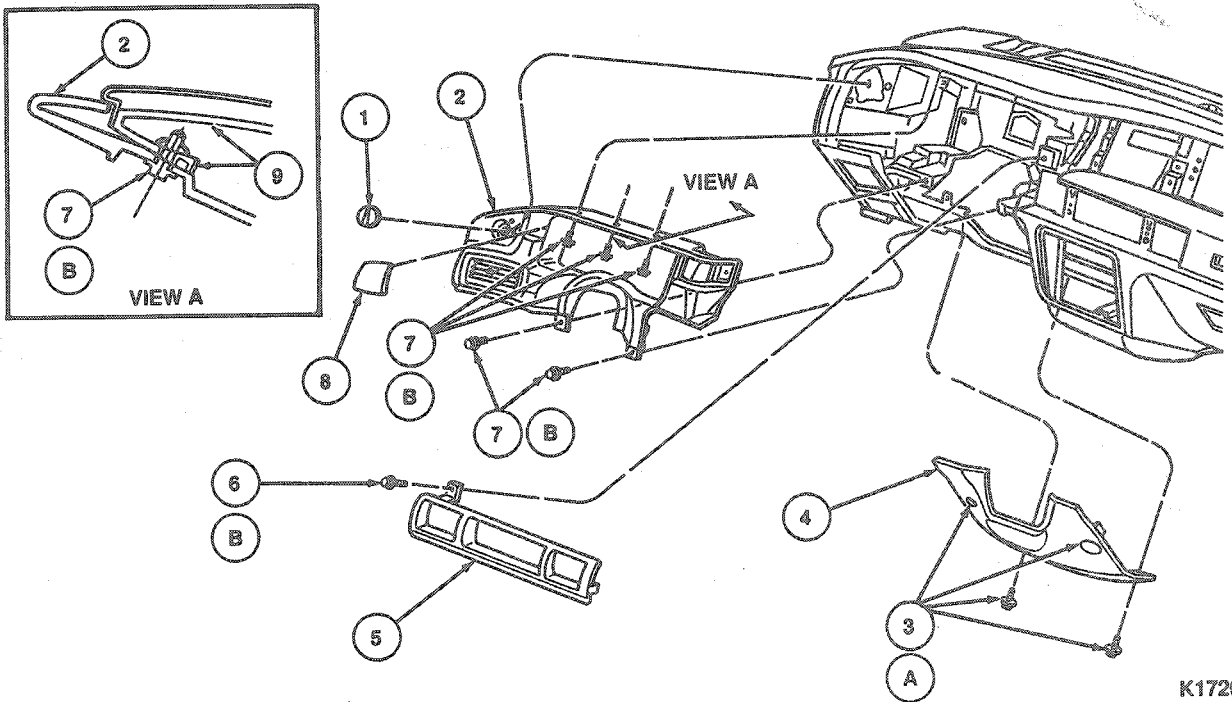

K17207-A

Item	Part Number	Description
1	11666	Lamp Switch Knob Assy
2	044D70	Instrument Panel Cluster Assy
3A	N804306-S36B	Screw (4 Req'd)
4	046A72	Steering Column Opening Cover Assy
5	044A92	Instrument Panel Upper Center Finish Panel Assy
6B	N804306-S36B	Instrument Panel Upper Center Finish Panel Screw

(Continued)

Item	Part Number	Description
7B	N804306-S36B	Instrument Panel Cluster Assy Screws (5 Req'd)
8	044F58	Instrument Panel Control Opening Cover
9	—	Instrument Panel Cover and Pad Assy
A	—	Tighten to 9-14 N·m (80-124 Lb·In)
B	—	Tighten to 2-3 N·m (18-27 Lb·In)

TK17207A

REMOVAL AND INSTALLATION (Continued)

Bulb, Illumination

Removal and Installation

WARNING: ILLUMINATION BULBS ARE PRESSURIZED AND MAY SHATTER IF IMPROPERLY HANDLED. WEAR EYE PROTECTION WHEN SERVICING ILLUMINATION BULBS.

1. Remove instrument cluster as outlined.
2. Allow illumination bulbs to cool before servicing.
3. Remove bulb and socket assembly. Dispose of carefully.
4. Install new bulb and socket assembly.
5. Install instrument cluster as outlined. Check instrument panel illumination.

Low Fuel Warning Assembly, Electronic

Removal and Installation

1. Remove instrument cluster as outlined.
2. Depress clip retaining assembly to lower left of cluster (rear view) backplate and remove assembly.
3. Position assembly in pocket slides and push inward to fully snap assembly in cluster.
4. Install instrument cluster as outlined.

Flexible Printed Circuit

Removal

1. Remove instrument cluster as outlined.
2. Remove low fuel warning assembly as outlined.
3. Remove all bulb and socket assemblies by twisting counterclockwise.

4. Remove speedometer and gauges. Refer to Section 13-02.
5. Remove clips using long-nose pliers. Squeeze both ends of clip equally so that locking ears will slide through clip opening in backplate. Push clip through opening.
CAUTION: Do not overbend clips as they may break.
6. After all clips are removed, printed circuit can be removed.

Installation

1. Position printed circuit on backplate and install clips by bending tabs on clips with fingers. Push clip into clip opening until locking ears are locked into backplate.

NOTE: An audible click will be heard when clips are locked into position.

2. Install speedometer and gauges as outlined.
3. Install all bulb and socket assemblies into backplate by twisting clockwise.
4. Install low fuel warning assembly as outlined.
5. Install instrument cluster as outlined.

SPECIFICATIONS

TORQUE SPECIFICATIONS

Description	N-m	Lb-in
Instrument Cluster Screws	2-3	18-27
Steering Column Opening Cover Screws	9-14	80-124