

# INSTRUMENTATION AND WARNING SYSTEMS

GROUP

# 13

(10000 &amp; 19000)

SECTION TITLE	PAGE	SECTION TITLE	PAGE
CHARGING SYSTEM GAUGE / WARNING INDICATOR .....	13-04-1	INSTRUMENT CLUSTER—CONVENTIONAL .....	13-01B-1
CLOCK.....	13-07-1	INSTRUMENT CLUSTER—ELECTRONIC .....	13-01A-1
FUEL GAUGE AND LOW FUEL WARNING .....	13-03-1	SPEEDOMETER / ODOMETER .....	13-02-1
GAUGES, WARNING DEVICES, MISCELLANEOUS—ELECTRONIC .....	13-09-1	TACHOMETER, OIL PRESSURE, COOLANT TEMPERATURE GAUGES / WARNING INDICATORS .....	13-05-1
HORN.....	13-06-1		

## SECTION 13-01A Instrument Cluster—Electronic

SUBJECT	PAGE	SUBJECT	PAGE
<b>DESCRIPTION AND OPERATION</b>		<b>DIAGNOSIS AND TESTING (Cont'd.)</b>	
Digital Odometer .....	13-01A-3	Quick Checks .....	13-01A-5
Digital Speedometer.....	13-01A-3	Speedometer .....	13-01A-6
Fuel Computer.....	13-01A-4	Tachometer Circuit.....	13-01A-7
Fuel Computer Functions .....	13-01A-4	Windshield Washer Level .....	13-01A-8
Fuel Temperature Gauges .....	13-01A-3	<b>PARTS CROSS-REFERENCE .....</b>	<b>13-01A-34</b>
Speedometer / Odometer / Tachometer .....	13-01A-3	<b>REMOVAL AND INSTALLATION</b>	
Switch Module.....	13-01A-2	Cluster Assembly .....	13-01A-30
System Scanner .....	13-01A-5	Electronic Low Fuel Warning Assembly.....	13-01A-32
Tachometer Bargraph.....	13-01A-3	Fuel Lines.....	13-01A-31
<b>DIAGNOSIS AND TESTING</b>		Fuel Pump and Sender Unit Assembly .....	13-01A-31
Charging System.....	13-01A-7	Mask Assembly .....	13-01A-30
Coolant Temperature Sender.....	13-01A-8	Switch Module .....	13-01A-31
Dimmer Circuit .....	13-01A-6	Vehicle Speed Sensor.....	13-01A-31
Fuel Gauge.....	13-01A-6	<b>SPECIAL SERVICE TOOLS .....</b>	<b>13-01A-34</b>
Lamp Out Warning .....	13-01A-6	<b>SPECIFICATIONS.....</b>	<b>13-01A-34</b>
Oil Level Warning.....	13-01A-9	<b>VEHICLE APPLICATION .....</b>	<b>13-01A-1</b>

### VEHICLE APPLICATION

Taurus / Sable.

## DESCRIPTION AND OPERATION

The electronic instrument cluster is a single module which contains an electronic speedometer / odometer / tachometer fuel computer, system scanner and electronic fuel and engine coolant temperature gauges. It also contains the following warning indicators:

- Battery
- Safety belt
- Brakes
- High beams
- Oil pressure
- Left turn signal
- Right turn signal

- Check engine (Malfunction Indicator Lamp - MIL)
- ANTI-LOCK
- AIR BAG

The electronic cluster is operational only when the ignition is in the RUN position. The electronic vacuum fluorescent displays are powered by a non-serviceable internal power supply (illumination bulbs are not used). When the headlamps are turned on, the cluster will dim according to the rheostat position (except warnings which will not dim).

Each time the ignition is first turned from OFF to RUN position, the electronic displays of the modules will prove out by momentarily lighting all of the display segments and then momentarily turning all display segments off. After the prove out, the modules return to normal operation.

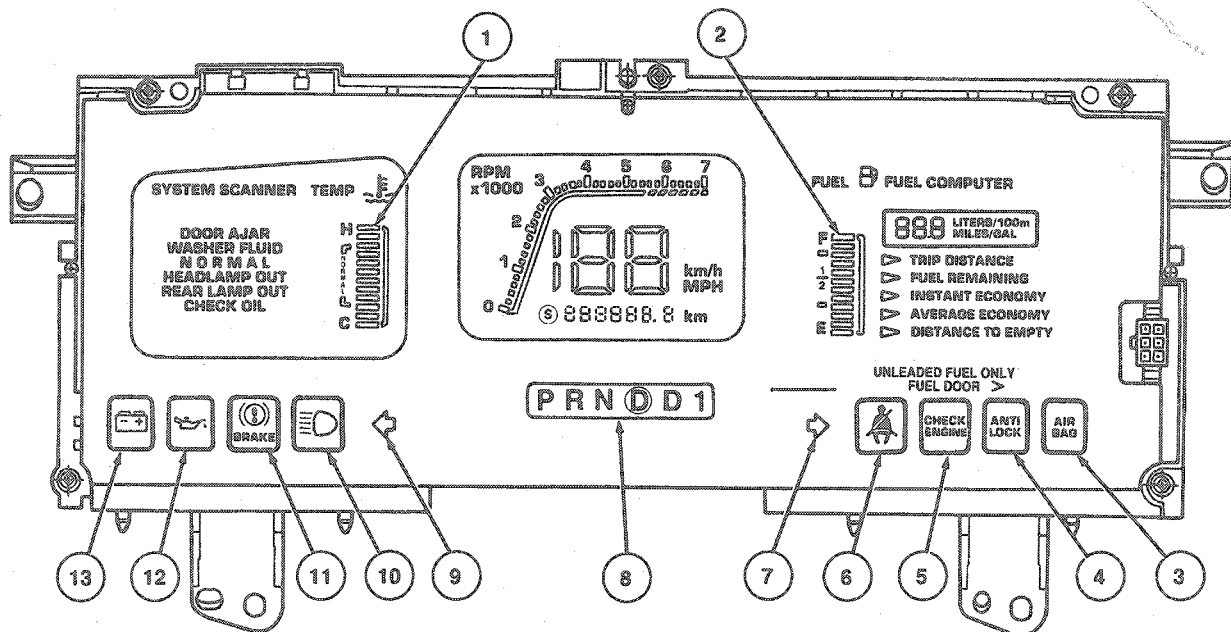

K14572-B

Item	Description
1	Temperature Gauge
2	Fuel Gauge
3	Air Bag Indicator
4	Anti-Lock Indicator
5	Check Engine Indicator (MIL)
6	Safety Belt Indicator

(Continued)

Item	Description
7	RH Turn Signal
8	Transmission Selector Indicator
9	LH Turn Signal
10	High Beam Indicator
11	Brake Indicator
12	Oil Pressure Indicator
13	Charging System Indicator

### Switch Module

The switch module is located immediately to the RH side of the instrument cluster. The switch module consists of the following four buttons:

**SELECT:** Moves cursor from top to bottom.

**E/M:** Alternately switches EIC information from English to Metric mode.

**TACH:** Activates and deactivates tachometer.

## DESCRIPTION AND OPERATION (Continued)

**RESET:** Resets function selected in fuel computer. Two successive depressions of reset button within two seconds will cause all resettable functions to reset.

All buttons are white with headlamp switch off and are illuminated in green with the headlamp switch on. Dimming is controlled by the rheostat.

The button actuations are accompanied by an audible tone generated by the vehicle chime module which is activated by the instrument cluster.

### Speedometer/Odometer/Tachometer

The electronic instrument cluster goes through prove out when powered up and then goes into normal operation, displaying speed and the regular odometer.

Two of the four buttons on the switch module are used to operate speedometer functions. They are:

- **E/M:** Displays in either English mode (MPH, MILES, MPG) or metric mode (Km/h, Km, L/100Km). This switch controls both the speedometer and fuel computer.
- **TACH:** Activates and deactivates tachometer display.

### Digital Speedometer

The electronic speedometer gets a speed/distance signal from the cableless transmission-mounted vehicle speed sensor (VSS) (9E731).

The speedometer portion of the display consists of 2-1/2 digits which indicate vehicle speed. The mode (English or metric) will also be indicated by displaying either the MPH or Km/h legends. The display units (English or metric) will be consistent with the odometer and fuel computer, and will be the same at power up as they were at power down.

The maximum speed indicated will be limited to 193 Km/h (120 mph). These readings will be displayed for all vehicle speeds exceeding 193 Km/h (120 mph). It is normal for the speedometer to display consecutive numbers during slow acceleration or deceleration, and to skip consecutive numbers during quick starts and stops.

### Digital Odometer

The digital odometer displays either miles or kilometers depending on the selection made with the E/M button. The odometer display, as well as the units (English or metric), will be the same at power up as at power down.

Accumulated mileage is stored in a non-volatile memory (NVM) every 1.6 Km (1.0 mi) and when the ignition switch is turned to the OFF position. The NVM saves both the total odometer mileage as well as the trip odometer mileage.

The total odometer display consists of 7 digits and a decimal point (leading zeros are displayed). The digit to the right of the decimal point represents tenths of a unit. The total odometer range is from 000000.0 to 858993.4 Km in the metric mode and to 925691.9 miles in the English mode. The displays will stop at these modes once attained and not roll over to zero.

When in the metric mode, the legend km will appear near the odometer.

**Service Alert:** If a condition exists where the speedometer module cannot read a valid odometer memory value from the non-volatile memory the word ERROR will be displayed.

**Replacement, Odometer/Service:** Replacement clusters may be obtained with odometers programmed with the actual vehicle mileage. When the S is displayed it indicates that the instrument cluster has been replaced with a service cluster with no mileage. The S can only be displayed when a service instrument cluster, programmed to light the S, is installed. Previous accumulated mileage is recorded on a door jamb sticker.

### Tachometer Bargraph

The tachometer gets its signal from the coil and displays engine rpm. The tachometer display consists of 36 bars and will indicate engine rpm from 0 to 7000 rpm. Engine rpm is indicated by the number of bars lit. Each bar represents 200 rpm.

For all engine speeds above 6600 rpm, the tach bargraph will indicate 7000 rpm.

### Fuel Temperature Gauges

**Engine Coolant Temperature Gauge:** The temperature gauge identifier, in addition to the H, C, and NORM graduations are illuminated when the cluster is powered. The H graduation is located just left of the top segment (No. 12) and the C graduation is located just left of the bottom segment (No. 1). The NORM graduation is centered vertically between the H and C graduations and two lines indicating normal range of operation. Specific temperature sender resistance ranges correspond to a specific number of illuminated segments in "fill up" format. When the coolant temperature exceeds the NORM range the temperature gauge indicator will begin to flash at a one Hz rate. A one-second audible tone will also be given to alert the driver of the abnormal condition. The audible alert will be repeated every five seconds.

**DESCRIPTION AND OPERATION (Continued)**

**Fuel Gauge (9280):** The fuel gauge identifier, in addition to the fuel level graduations are illuminated when the cluster is powered. Increasing fuel level will cause the display bars to illuminate from the E (No. 1) to F (No. 12). Specific fuel tank sending unit and pump (9H307) resistances correspond to a specific number of illuminated segments. When the fuel level falls below 8.7L (2.3 gal) the ISO will begin to flash at a one Hz rate to provide a low fuel warning. Two fuel sender diagnostics are included in the Fuel Computer display. They are indicated by alphabetic displays as follows:

**Fuel Tank Sending Unit and Pump Shorted:** FUEL REMAINING is displayed on power up with a value of "CS" indicating circuit shorted (DTE will also display "CS" if selected).

**Fuel Tank Sending Unit and Pump Open:** FUEL REMAINING on power up with a value of "CO" indicating circuit open (DTE will also display "CO" if selected).

In addition, the two top and bottom bars in the fuel gauge will illuminate when the fuel diagnostic codes are displayed.

**Fuel Computer**

The fuel computer takes in signals from the vehicle speed sensor, fuel sender and the Powertrain Control Module (PCM) 12B529. Speed information comes from the transmission-mounted vehicle speed sensor to the speedometer module, which in turn feeds the fuel computer. Fuel level information comes from the fuel tank sending unit and pump which is located in the fuel tank (9002), and the fuel flow information comes from the powertrain control module.

The fuel computer calculates and displays trip distance, fuel remaining, instantaneous economy, average economy, and distance to empty.

The fuel computer display consists of the fuel gauge, three digits with a decimal point, the legends LITERS / 100km and MILES / GAL, and the menu functions TRIP DISTANCE, FUEL REMAINING, INSTANT ECONOMY, AVERAGE ECONOMY, and DISTANCE TO EMPTY.

The fuel computer goes through prove out when powered up and then goes into normal mode by displaying the function selected before the last ignition switch turn off. All menu functions remain illuminated for three seconds following prove out, and the pointer preceding the selected function is also illuminated. After three seconds, the pointer and the nonselected functions will not be displayed. If the cluster memory has been reset by interrupting battery power to the cluster, the default display is TRIP DISTANCE.

Three of the four buttons on the switch module are used to operate the fuel computer functions. They are as follows:

- **SELECT:** Will move the menu cursor from top to bottom. The selected function is indicated by the position of the pointer.

- **E / M:** Will alternately cause the fuel computer information to be displayed in English or Metric units with successive depressions.
- **RESET:** Will reset the TRIP DISTANCE and AVERAGE ECONOMY functions when they are selected. Two successive depressions of the RESET button within two seconds will reset both of these functions regardless of the function currently selected. No other function can be reset.

**Fuel Computer Functions**

Each of the following functions may be selected by pressing the SELECT button on the switch module until the pointer preceding the desired function is illuminated. The appropriate numeric information is displayed with units in the three digit display above the menu.

**Trip Distance**

Trip distance is the distance travelled in tenths of kilometers or (miles) up to 99.0 (whole numbers above 99.9) since the Trip Distance was last reset. The value is displayed with leading zeros suppressed. The value rolls over to 0.0 after 999 kilometers or miles. The appropriate Km or MILES logo is displayed when Trip Distance is selected.

Trip Distance can be reset to 0.0 by pressing the RESET button while Trip Distance is selected.

**Fuel Remaining**

Fuel Remaining is the amount of fuel remaining in the fuel tank. The fuel remaining value will be consistent with the display of the FUEL bargraph segments. It is displayed in whole liters or gallons along with the LITERS or GAL logo. The numeric range of the fuel remaining display is from 54L (14 gal) down to 3L (1 gal). The value "F" (Full) is displayed above 54L (14 gal) and "E" (Empty) is displayed below 2L (1 gal).

Fuel remaining cannot be reset.

**Instantaneous Fuel Economy**

Instant economy is the fuel economy calculated at that instant. The instantaneous fuel economy value is displayed along with the LITERS / 100km or MILES / GAL logo. The range of Instant Economy which can be displayed is from 99 to 0 LITERS / 100km or from 0 to 99 MILES / GAL.

When the vehicle is not moving, Instant Economy is displayed as 99.9 to 0.0 LITERS / 100km or 0.0 to 99.9 MILES / GAL.

Instantaneous Fuel Economy cannot be reset.

**Average Fuel Economy**

Average economy is the fuel economy obtained since the Average Economy function was last reset. The average fuel economy value is displayed along with the LITERS / 100km or MILES / GAL logo. The range of average economy which can be displayed is from 99.9 to 0.0 LITERS / 100km (0.0 to 99.9 MILES / GAL).

## DESCRIPTION AND OPERATION (Continued)

Average economy can be reset by pressing the RESET button while Average Economy is displayed. A reset causes the current instantaneous fuel economy value to be displayed as the average fuel economy. This value is then updated according to continuing changes in vehicle speed and fuel consumption.

### Distance To Empty

Distance to empty (DTE) is the distance that can be travelled before the fuel tank becomes empty. The Distance To Empty value is displayed in whole kilometers or miles along with the km or MILES logo. The range of distance to empty which can be displayed is from 0 to 999 kilometers or miles.

NOTE: Distance to empty cannot be reset.

### Low DTE Alert

At 80 km (50 miles) to empty, the fuel computer self selects the Distance To Empty function, provides a one second audible tone, and flashes the DTE value for approximately five seconds. The display continues to indicate DTE (not flashing) until another function is selected. This alert will reoccur at 40 km (25 miles) and at 16 km (10 miles) to empty and at every subsequent power up below 80 km (50 miles) to empty.

### System Scanner

The system scanner takes inputs from the lamp out module, washer fluid level, oil level, and door ajar sensors and displays the appropriate diagnostic message. The engine coolant temperature electronic gauge is also included in the system scanner display. Based on the inputs from the various sensors, the system scanner will display the following messages:

- DOOR AJAR
- WASHER FLUID
- NORMAL
- HEADLAMP OUT
- REAR LAMP OUT
- CHECK OIL

When a warning condition first occurs, the diagnostic message is displayed accompanied by a one-second tone. The message will remain on the display as long as it is active, but no further tones are issued.

If more than one warning condition occurs, each message will be displayed simultaneously. When the message first appears it will be accompanied by a one second tone.

### DOOR AJAR

The door ajar signal comes from switches located in the door jamb. When any door is open, the appropriate wire to the system scanner will be grounded and the words DOOR AJAR will appear on the scanner display. The message will be cleared from the display when the warning condition is removed (the door is closed).

### WASHER FLUID LOW

The low washer fluid level signal comes from a switch located in the washer fluid reservoir. When the washer fluid level is low and the washer / wiper switch is activated, the wire to the system scanner will be pulled high and the words WASHER FLUID LOW will appear on the display. The message will remain displayed until key OFF.

### NORMAL

If no system faults are present at power up, the display will indicate NORMAL for five seconds following prove out before blanking. If a fault is present, the appropriate message is displayed immediately following prove out.

### HEADLAMP OUT

Indicates a Low-Beam Headlamp burnout when the light switch is turned to the headlamp position. The Lamp Outage Module provides the ground to light this message. Once the message appears it will remain on the display until the ignition switch is turned to the OFF position.

### REAR LAMP OUT

Indicates a Brake Lamp burn out when the brake pedal is pressed. It also indicates a Rear Parking Lamp burnout when the light switch is turned to either the parking lamp or headlamp position. The Lamp Outage Module provides the ground to light this message. Once the message appears it will remain on the display until the ignition switch is turned to the OFF position.

### CHECK OIL

The CHECK OIL signal comes from the oil level sensor in the oil pan. The CHECK OIL message is illuminated when the oil level is low. Refer to Section 13-09 for information on the low oil level indicator.

## DIAGNOSIS AND TESTING

### Quick Checks

#### Tool Required:

- Rotunda Digital Volt Ohmmeter 014-00407

Use the electronic instrument cluster (EIC) system schematics and descriptions with Quick Checks for an isolated view of each system for troubleshooting purposes. The description provides an understanding of how the system works, and the Quick Check tells what should happen during operation.

The Diagnostic by Symptom section uses pinpoint tests to service the most likely concerns with the EIC. The Diagnostic by System section gives an overview of the entire system.

Voltage and resistance measurements may be obtained using Rotunda Digital Volt Ohmmeter 014-00407 or equivalent.

**DIAGNOSIS AND TESTING (Continued)**

**Speedometer**

**Description**

- A vehicle speed sensor (VSS) (9E731) mounted on the transaxle sends pulses to the instrument cluster. The pulses also go to the powertrain control module and variable assist power steering (VAPS) module, if so equipped.

**Quick Check**

- Verify speedometer by road testing vehicle.
- If speedometer reads zero, high or erratic, then road test speed control. Speed control is performed by the powertrain control module. If speed control does not work properly, concern is not the speedometer.

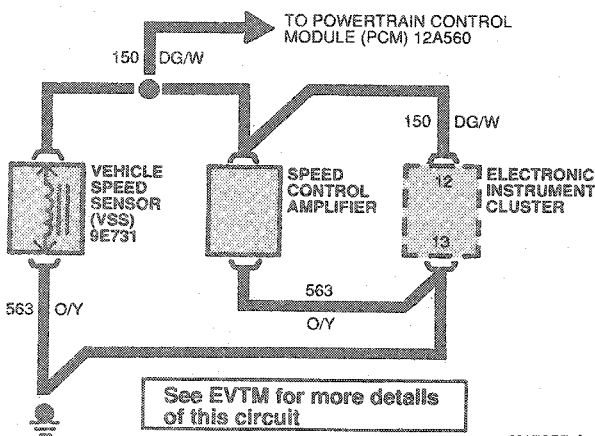

K17655-A

**Lamp Out Warning**

**Description**

- There is a Lamp Outage Module that monitors the brakelamps, rear park lamps and low beam headlamps. If any of these lamps are burned out, the lamp outage module will ground the appropriate circuit when the lamp is turned on. This signals the message center to display a warning message.

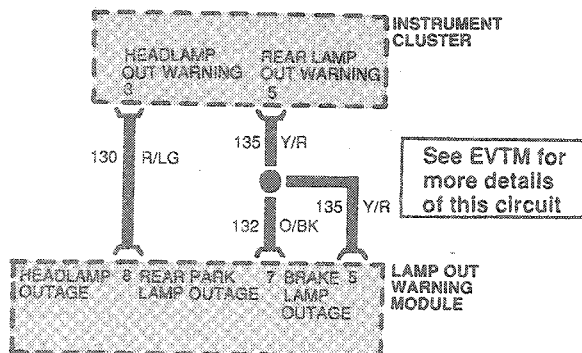

K17656-A

**Fuel Gauge**

**Description**

- The cluster looks for resistance values at fuel tank sending unit and pump to be in the range of 11 ohms to 168 ohms.

**Quick Check**

- Be certain of fuel level.
- Fuel gauge does not display rapid change in fuel level. Turn ignition switch to OFF position, wait 10 seconds, then turn ignition switch to the RUN position.
- Diagnostic bars (top two and bottom two bars lighted) indicate that fuel tank sending unit and pump circuit is out-of-range. Also the digital displays either CO or CS. This means:
  - CO: Circuit open or resistance higher than 178 ohms.
  - CS: Circuit short or resistance less than 7 ohms.

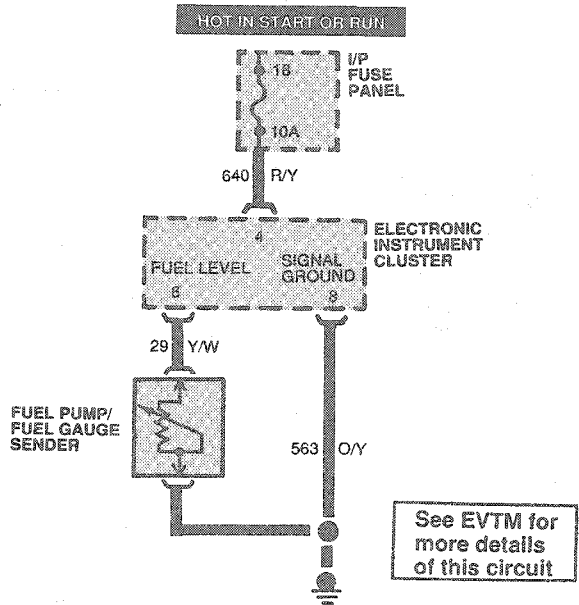

K17657-A

**Dimmer Circuit**

**Description**

- When the headlamps are turned on, dimming voltage is supplied to Connector A, Pin 13 and Connector B, Pin 6. Dimming voltage varies between 5 volts and battery voltage depending on the rheostat position. The feed to Connector A is used to dim the VF (vacuum fluorescent) displays. The feed to Connector B provides power to the PRNDL bulb only.



## DIAGNOSIS AND TESTING (Continued)

### Quick Check

- Verify that the fuse is ok.
- Check to see that all dimmable functions dim properly.
- Check for proper voltages at cluster.

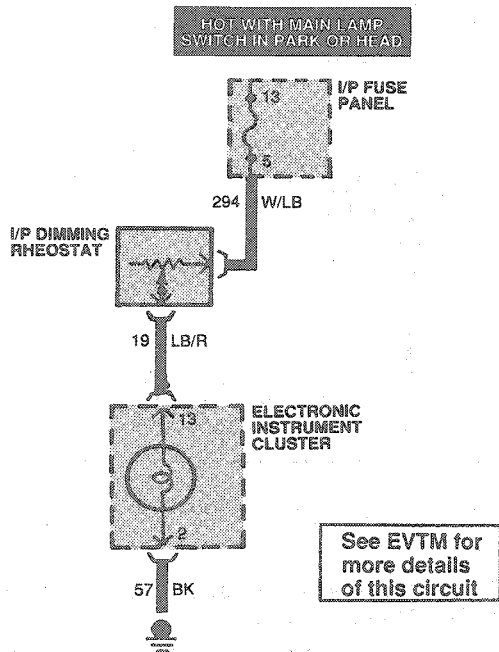

K17658-A

### Tachometer Circuit

#### Description

- The tachometer signal feed to the cluster is accomplished through Circuit 11 (DG-4). The signal is supplied to the cluster through Connector A, Pin 20. The cluster interprets the signal and displays rpm.

### Quick Check

- Verify signal to cluster.
- Service Circuit 11 or replace cluster as required.

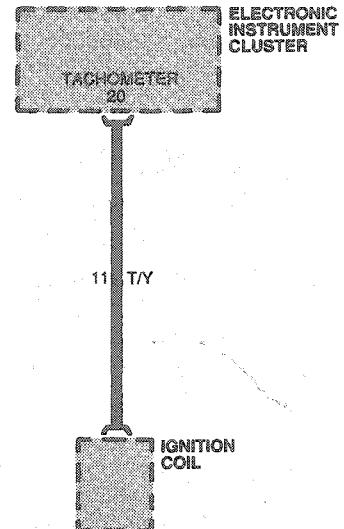

K17659-A

### Charging System

#### Description

- Connected between Connector B, Pins 17 and 18 is the charge warning indicator and 422 ohm resistor (internal to the cluster). When a charging system concern occurs, Circuit 904 is grounded through the generator regulator and the warning indicator illuminates.

NOTE: If Connector B is disconnected, the vehicle will not produce a charge. The 422 ohm resistor allows the charging system to operate with a burned out warning indicator bulb.

**DIAGNOSIS AND TESTING (Continued)**

**Quick Check**

- Look for a charging system warning that normally occurs with key in RUN position, engine off. The warning should come on within approximately 15 to 20 seconds.
- Start engine and charging system warning should go away. Wait at least 15 seconds.

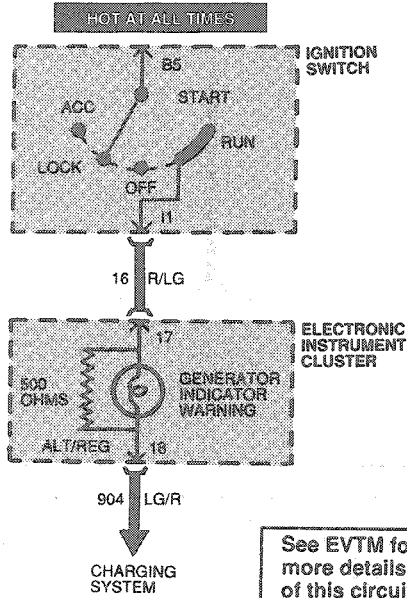

K17660-A

**Windshield Washer Level**

**Description**

- The fluid level sensor is open when level is full. When fluid is low the sensor switch closes. The next time washer fluid is used, run voltage is fed to Connector B, Pin 15 through the sensor. Washer fluid will then light and remain on until the next key cycle.

**Quick Check**

- Turn ignition switch to OFF position. Disconnect harness connector near sensor. Turn ignition switch to RUN position. No warning should be displayed.
- Turn ignition switch to OFF position. Place jumper across signal and ground at harness connector. Turn ignition switch to RUN position. A warning should be displayed.

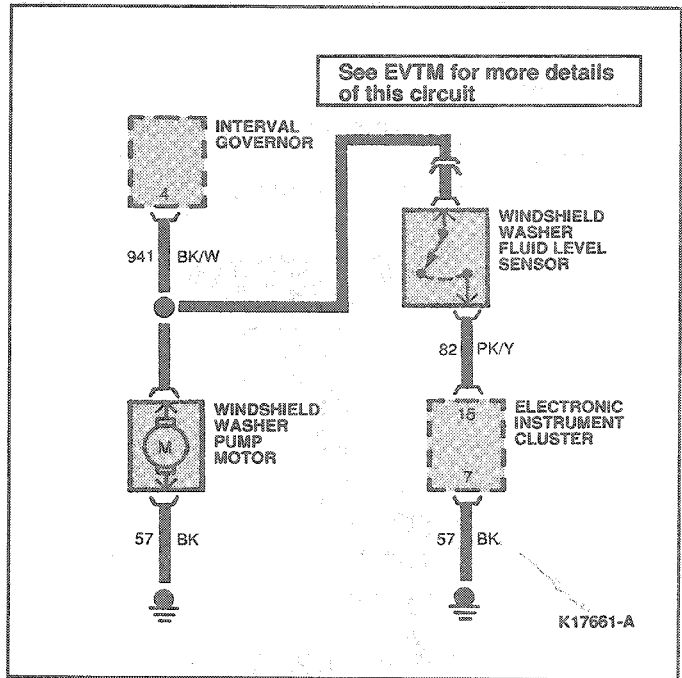

K17661-A

**Coolant Temperature Sender**

**Description**

- Temperature sender resistance varies depending on coolant temperature.
- The cluster interprets the resistance and displays the temperature in the cluster.

**Quick Check**

- Sender resistance should be between 1400 and 12,000 ohms with engine at normal operating temperature.
- Verify continuity in Circuit 39.

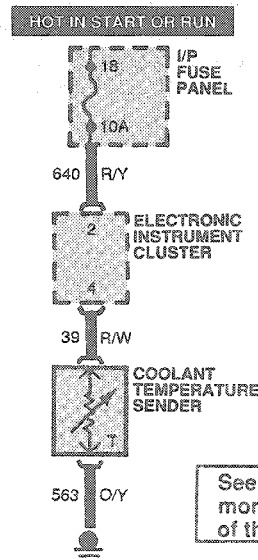

K17662-A



## DIAGNOSIS AND TESTING (Continued)

### Oil Level Warning

#### Description

- The sensor switch is open when level is full. The switch is closed when the level is low. A closed switch grounds the sensor circuit.
- It takes a two minute wait with ignition switch in OFF position to charge the warning.

#### Quick Check

- Check oil level with the dipstick.
- Turn ignition switch to OFF position. Disconnect oil level sensor. Wait two minutes, then turn ignition switch to RUN position. No warning should be displayed.
- Turn ignition switch to OFF position. Attach a jumper from harness connector to ground. Wait two minutes. Turn ignition switch to RUN position. A warning should be displayed.

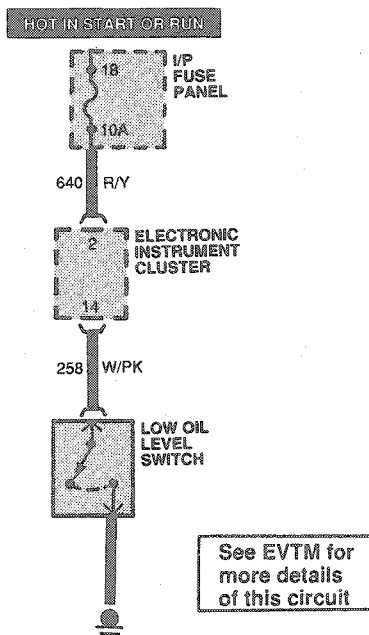

K17663-A

**NOTE:** Prior to following symptoms chart, check instrument cluster as follows:

1. Depress E/M and Select simultaneously while turning the vehicle key from OFF to the RUN position. The cluster will enter special test mode and display information in the center display opening. Information displayed includes a number in the speedometer and two numbers in the odometer. The tachometer bar will also be illuminated. Both the left and right display openings will be off.
2. If any of the information in the center opening flashes on and off continuously, the instrument cluster is damaged and should be replaced. If the display does not flash, turn key off to leave the special test mode. Continue through the diagnosis section. (The cluster may or may not be faulty at this point).

DIAGNOSIS AND TESTING (Continued)

Wiring Schematic

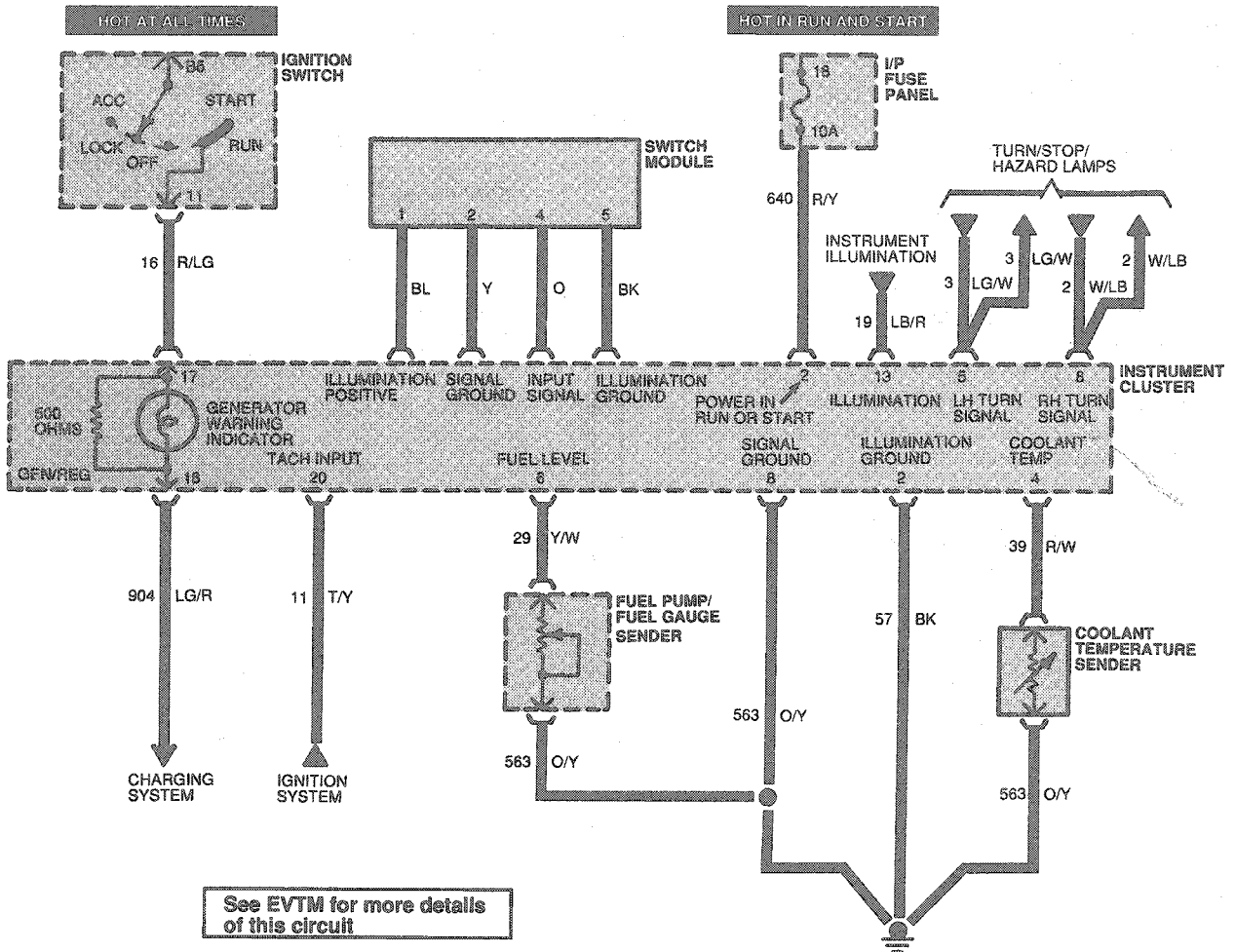

K17664-A

DIAGNOSIS AND TESTING (Continued)

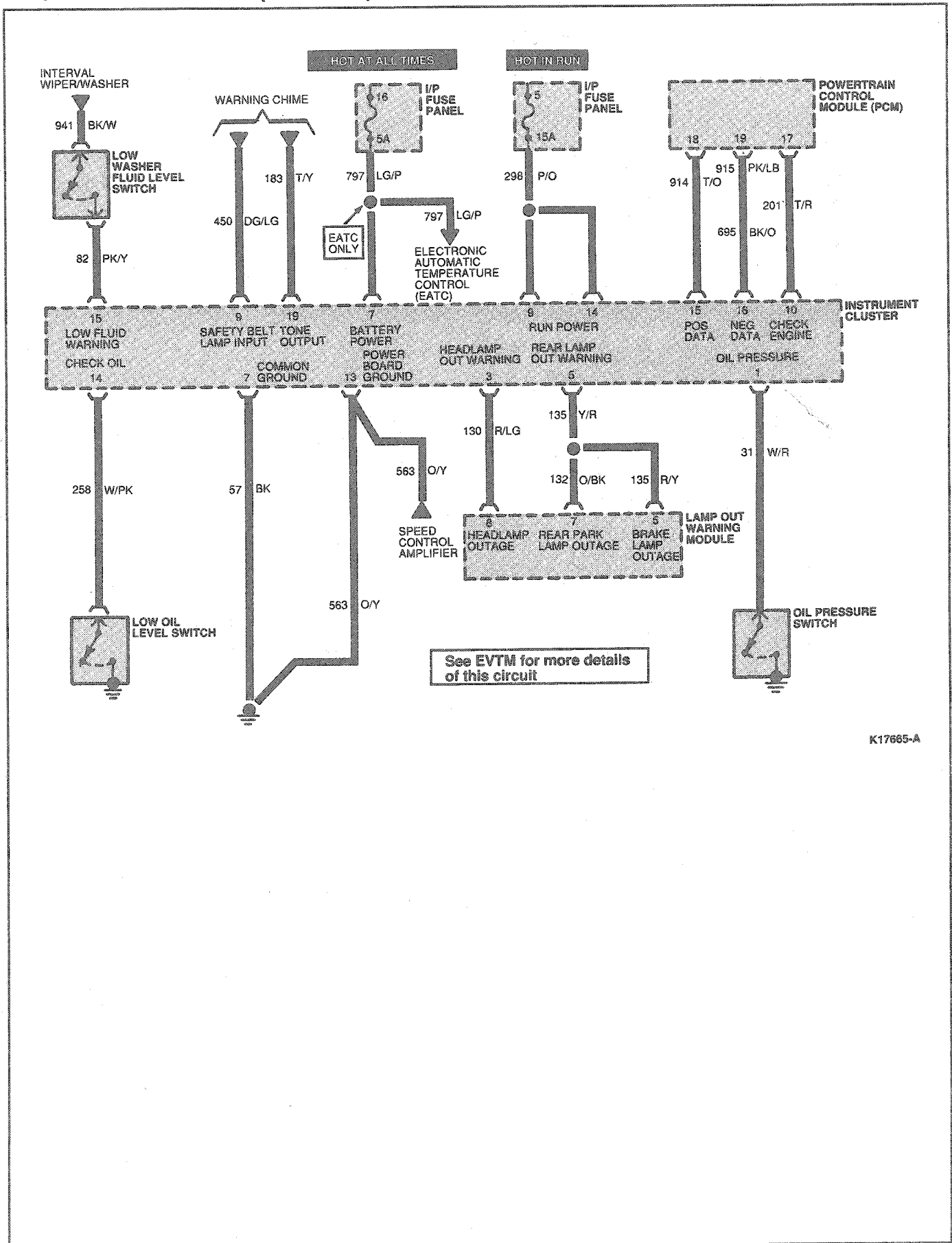

K17665-A

DIAGNOSIS AND TESTING (Continued)

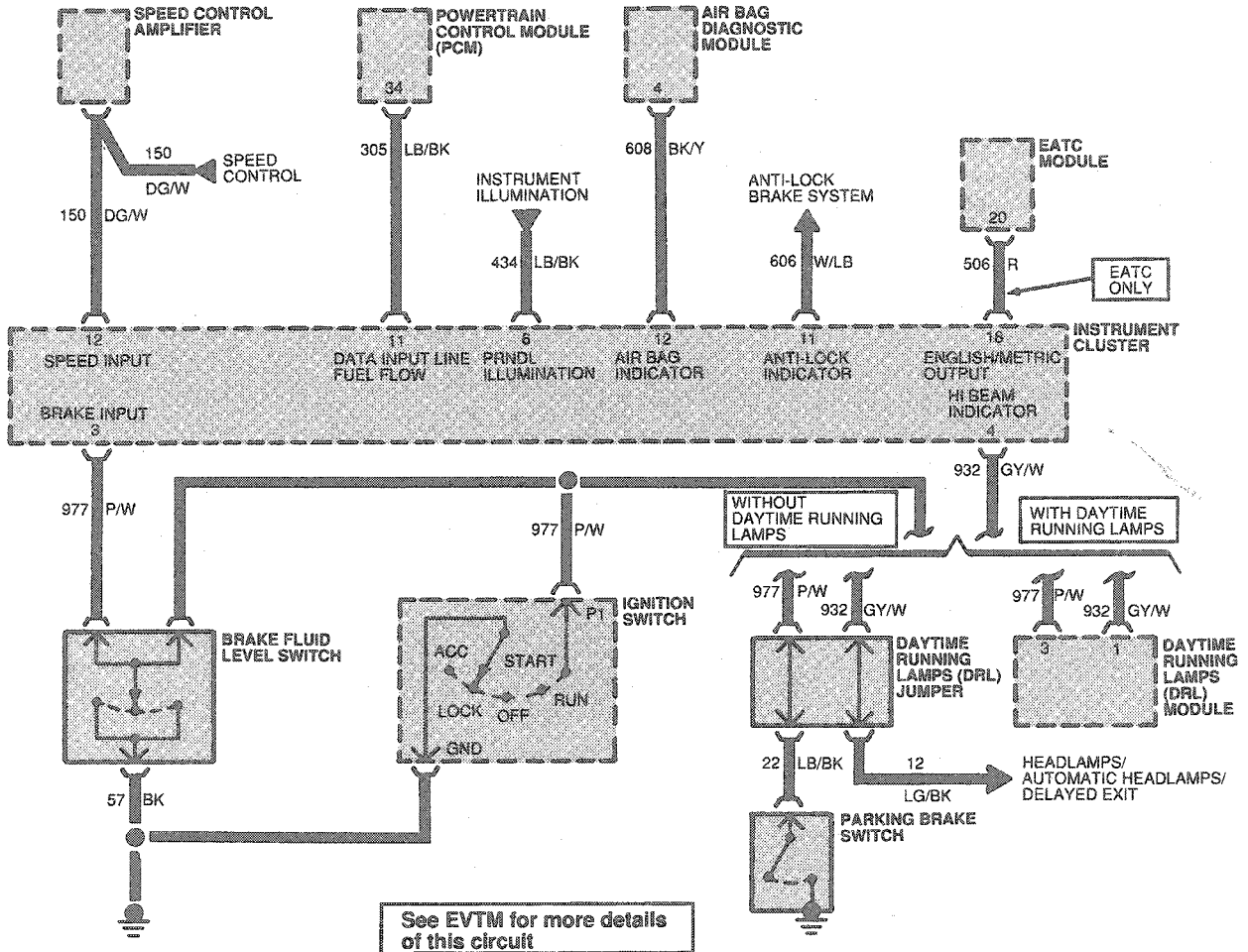

K17666-A

DIAGNOSIS AND TESTING (Continued)

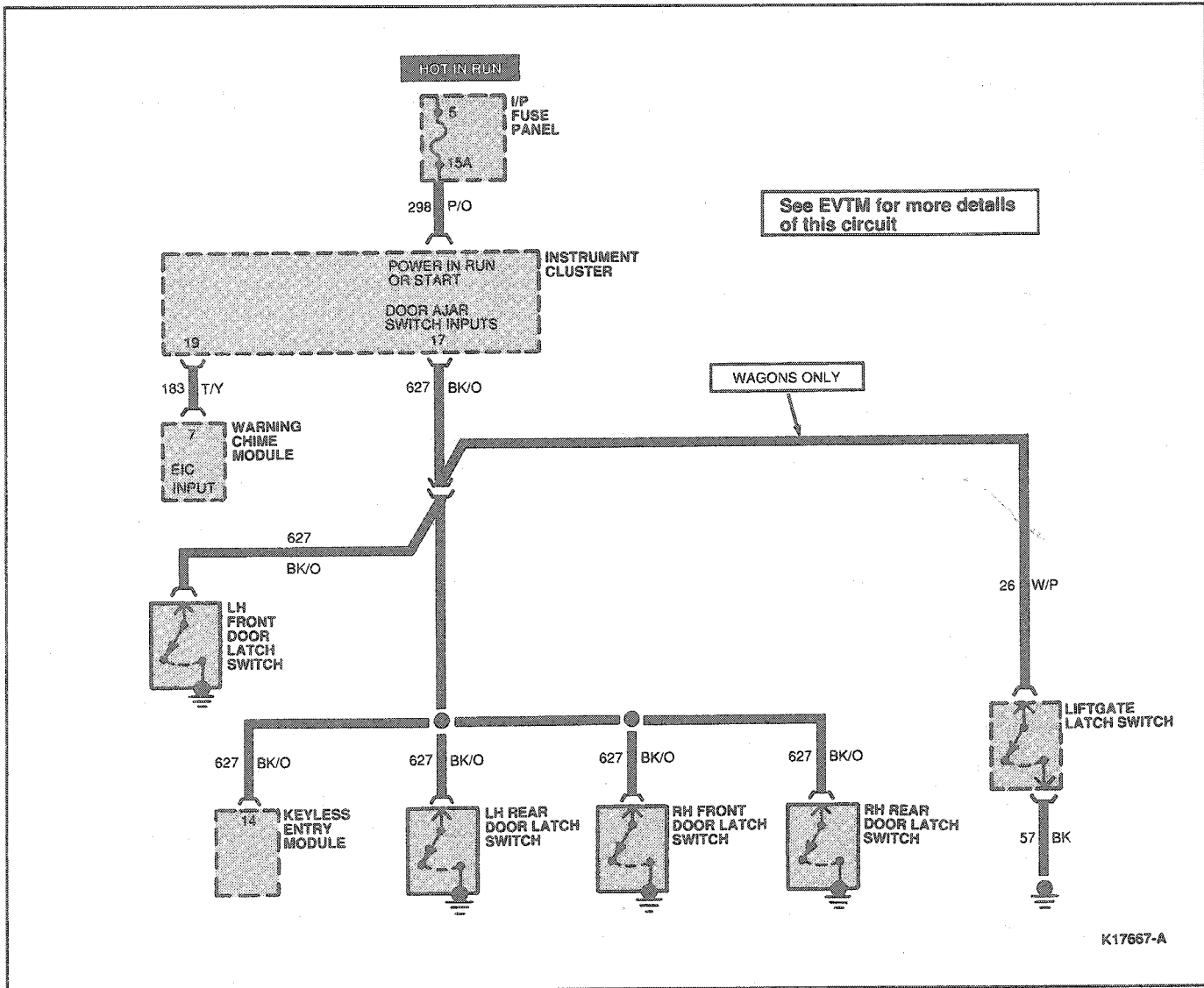

K17657-A

Wiring Harness Connectors  
C255

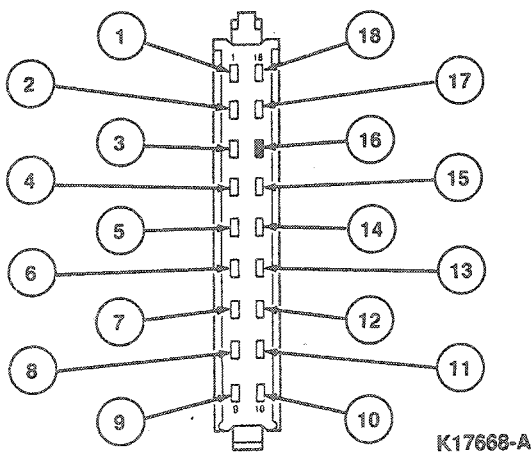

PIN NUMBER	CIRCUIT	CIRCUIT FUNCTION
1	31 (W/R)	Oil Pressure Indicator to Oil Pressure Sending Unit
2	640 (R/Y)	Warning Lamps Feed-Hot in RUN or START
3	977 (P/W)	Brake Warning Switch to Indicator Lamp
4	932 (GY/W)	Hi Beam Indicator
5	3 (LG/W)	LH Turn Signal Lamps
6	434 (LB/BK)	Instrument Panel Lamp Feed
7	57 (BK)	Ground
8	2 (W/LB)	RH Turn Signal Lamps
9	450 (DG/LG)	Safety Belt Warning Indicator Lamp Feed
10	201 (T/R)	PCM to Check Engine Lamp

(Continued)

## DIAGNOSIS AND TESTING (Continued)

PIN NUMBER	CIRCUIT	CIRCUIT FUNCTION
11	606 (W/LB)	Anti-Lock Brake Indicator for Anti-Lock Brake Control Module
12	608 (BK/Y)	Air Bag Indicator to Air Bag Diagnostic Module
13	563 (O/Y)	Ground
14	298 (P/O)	Hot in RUN
15	82 (PK/Y)	Washer Fluid Level Indicator
16	—	Not Used
17	16 (R/LG)	Ignition Switch to Ignition Coil "Battery" Terminal
18	904 (LG/R)	Coil Terminate or Ignition Switch to Generator Regulator

## C256

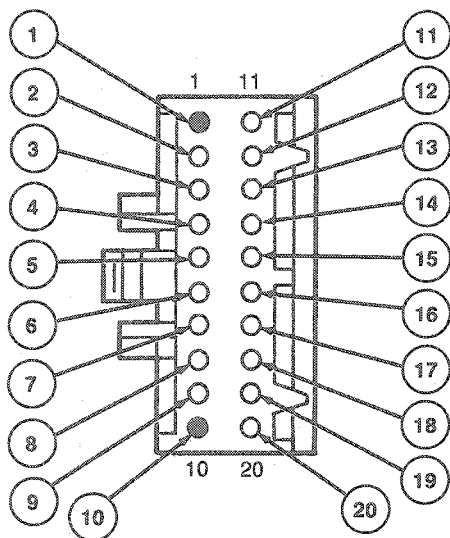

K17669-A

PIN NUMBER	CIRCUIT	CIRCUIT FUNCTION
1	—	Not Used
2	57 (B/K)	Ground
3	130 (R/LG)	Headlamp Bulb Outage
4	39 (R/W)	Temperature Gauge to Coolant Temperature Sensor
5	135 (Y/R)	Rear Lamp Outage
6	29 (Y/W)	Fuel Gauge and Fuel Gauge Sender
7	797 (LG/P)	Battery Power
8	563 (O/Y)	Reference Ground
9	298 (P/O)	Hot in RUN
10	—	NOT USED
11	305 (LB/BK)	PCM to Time Meter*
12	150 (DG/W)	Vehicle Speed Sensor
13	19 (LB/R)	Instrument Panel Lamp Feed
14	258 (W/PK)	Oil Level Sensor
15	696 (O/BK)	PCM Positive Data
16	695 (BK/O)	PCM Negative Data
17	627 (BK/O)	Open Door Warning Lamp to Open Door Switch
18	506 (R)	English/Metric Output
19	183 (T/Y)	Tone Generator
20	11 (T/Y)	Electronic Switch to Ignition Coil Negative Coil



DIAGNOSIS AND TESTING (Continued)

FUNCTION DIAGNOSTIC MODE

Temp Gauge

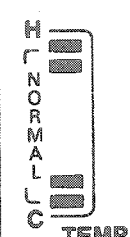

Engine Temperature Sensor Input Short Circuited Lights Top two Red Bars and Bottom two Bars. All Other Temperature Gauge Segments Will Be Off.

TEMP

Fuel Gauge

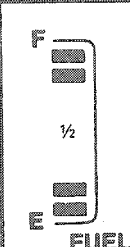

Fuel Level Sender Input Short Circuited or Open Circuited Lights Top two and Bottom two Bars. All Other Fuel Gauge Segments Will Be Off.

FUEL

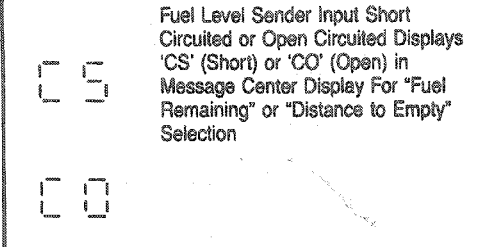

Fuel Level Sender Input Short Circuited or Open Circuited Displays 'CS' (Short) or 'CO' (Open) in Message Center Display For "Fuel Remaining" or "Distance to Empty" Selection

Odometer

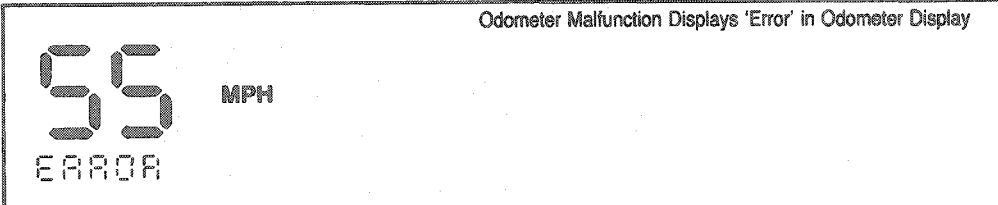

Odometer Malfunction Displays 'Error' in Odometer Display

K14771-A

PINPOINT TEST INDEX

	SYMPTOM	GO to
<b>DISPLAY DIAGNOSIS</b>		
1	Display totally black	Pinpoint Test TA
2	Cluster will not dim	Pinpoint Test TD
3	Display lit but too dim	Pinpoint Test TB
4	Display scrambled, segments half lit (ghost segments), segments blinking or missing, display incorrect all the time	Pinpoint Test TC
5	Display stuck with all segments on	Pinpoint Test TC
6	No beep when buttons pushed or driver alert given	Pinpoint Test SA
7	Cluster does not respond to buttons	Pinpoint Test SA
<b>TEMPERATURE GAUGE DIAGNOSIS</b>		
8	Temperature gauge display blanks out thermometer symbol and lights top two and bottom two bars of multigauge	Pinpoint Test TE
9	No warning tone when thermometer symbol is blinking	Pinpoint Test TX
10	Temperature gauge always indicates cold temperature	Pinpoint Test TF
<b>SPEEDOMETER DIAGNOSIS</b>		
11	Reads 0 mph (km/h) at all speeds when vehicle in motion	Pinpoint Test SB
12	Speedometer reads constantly too high or too low	Pinpoint Test SC
13	Speed indication jumps up and down erratically	Pinpoint Test SD

(Continued)

## DIAGNOSIS AND TESTING (Continued)

## PINPOINT TEST INDEX (Cont'd)

	SYMPTOM	GO to
<b>ODOMETER DIAGNOSIS</b>		
14	Display reads "Error" and service symbol on	Pinpoint Test SE
15	Display has "S" illuminated	Pinpoint Test SF
16	Odometer does not accumulate mileage, or counts 1.6 km (1.0 miles) and jumps back 1.6 km (1.0 miles)	Pinpoint Test SG
17	Odometer reading incorrect	Pinpoint Test SH
18	Mileage constantly reads too high or too low	Pinpoint Test SJ
<b>TACHOMETER DIAGNOSIS</b>		
19	Tachometer always indicates too high or low	Pinpoint Test SK
20	No tachometer indication	Pinpoint Test SK
21	Tachometer indication erratic	Pinpoint Test SK
<b>FUEL COMPUTER DISPLAY DIAGNOSIS</b>		
22	Instantaneous fuel economy always reads zero miles/gal or 99/100 km, or 99 miles/gal or 0 L/100 km	Pinpoint Test FA
23	Trip distance does not accumulate	Pinpoint Test FB
24	Instantaneous fuel economy always reads 99 miles/gal or 0 L/100 km	Pinpoint Test FA
25	DTE does not go below 322 km (200 miles) with fuel tank empty	Pinpoint Test FC
26	DTE always reads zero miles	Pinpoint Test FC
<b>FUEL GAUGE DIAGNOSIS</b>		
27	CO displayed, when fuel remaining or DTE selected on fuel computer	Pinpoint Test FD
28	CS displayed, when fuel remaining or DTE selected on fuel computer	Pinpoint Test FE
29	Does not display F when fuel tank is full	Pinpoint Test FF
30	Does not display E when fuel tank is empty	Pinpoint Test FF
31	Inaccurate fuel indication	Pinpoint Test FF
<b>SYSTEM SCANNER DIAGNOSIS</b>		
32	Door ajar on at all times or never illuminates when doors are open	Pinpoint Test FG
33	Washer fluid illuminated at all times or never illuminates	Pinpoint Test FP
34	Lamp out warnings do not function properly	Pinpoint Test FI
35	Check oil does not function properly	Pinpoint Test FJ

## PINPOINT TEST TA: DISPLAY PARTIALLY ILLUMINATED OR COMPLETELY BLACK

TEST STEP	RESULT	ACTION TO TAKE
<b>TA1</b> VERIFY CONDITION		
<ul style="list-style-type: none"> <li>Turn ignition to the RUN position.</li> </ul>	Cluster partially illuminated	▶ GO to TA2.
	All displays black	▶ GO to TA3.
<b>TA2</b> VERIFY ABNORMAL CONDITION		
<ul style="list-style-type: none"> <li>Check to see if all choices (segments) except the one selected go black.</li> </ul>	All segments except one selected go black	▶ System OK.
	Cluster partially black	▶ REPLACE cluster.
<b>TA3</b> CHECK FUSES		
<ul style="list-style-type: none"> <li>Check Circuits 797 and 298 for blown fuses (battery and run voltage to cluster).</li> <li>Is fuse OK?</li> </ul>	No	▶ GO to TA4.
	Yes	▶ GO to TA5.

**DIAGNOSIS AND TESTING (Continued)**

**PINPOINT TEST TA: DISPLAY PARTIALLY ILLUMINATED OR COMPLETELY BLACK (Continued)**

TEST STEP		RESULT	ACTION TO TAKE										
<b>TA4</b>	<b>CHECK FOR SHORTS</b>	No Yes	REPLACE fuse. SERVICE circuit as required.										
	<ul style="list-style-type: none"> <li>Turn ignition to OFF.</li> <li>Disconnect battery ground cable.</li> <li>Connect an ohmmeter from circuit with blown fuse to ground.</li> <li>Is there continuity?</li> </ul>												
<b>TA5</b>	<b>CHECK FOR POWER TO FUSE</b>	Yes No	GO to TA6. SERVICE open in fuse holder.										
	<ul style="list-style-type: none"> <li>Connect battery.</li> <li>Turn ignition to RUN.</li> <li>Measure voltage from Circuits 797 and 298 to ground.</li> <li>Is voltage greater than 9 volts?</li> </ul>												
<b>TA6</b>	<b>CHECK FOR LOOSE CONNECTIONS</b>	No Yes	SERVICE as required. GO to TA7.										
	<ul style="list-style-type: none"> <li>Remove cluster (leave connected).</li> <li>Connect battery.</li> <li>Turn ignition to RUN.</li> <li>Wiggle A and B connectors on rear of cluster.</li> <li>Are connectors OK?</li> </ul>												
<b>TA7</b>	<b>CHECK POWER AND GROUND</b>	Yes No	REPLACE cluster. SERVICE Circuit BATT 797 RUN 298 GROUND 359.										
	<ul style="list-style-type: none"> <li>Turn ignition to OFF.</li> <li>Remove cluster as outlined.</li> <li>Turn ignition to RUN.</li> <li>Measure voltage at the harness connector A and B of the cluster.</li> <li>Voltage should be:</li> </ul> <table border="1" style="width: 100%; border-collapse: collapse;"> <thead> <tr> <th>PIN</th> <th>FUNCTION</th> <th>VOLTAGE</th> </tr> </thead> <tbody> <tr> <td>7A</td> <td>BATT</td> <td>Battery Voltage</td> </tr> <tr> <td>9A</td> <td>RUN</td> <td>Battery Voltage</td> </tr> <tr> <td>14B</td> <td>RUN</td> <td>Battery Voltage</td> </tr> </tbody> </table> <ul style="list-style-type: none"> <li>Check continuity of ground circuit Pins 8A and 13B to battery ground.</li> <li>Are voltage and continuity present?</li> </ul>			PIN	FUNCTION	VOLTAGE	7A	BATT	Battery Voltage	9A	RUN	Battery Voltage	14B
PIN	FUNCTION	VOLTAGE											
7A	BATT	Battery Voltage											
9A	RUN	Battery Voltage											
14B	RUN	Battery Voltage											
<b>TA8</b>	<b>CHECK FLEX CIRCUIT BOARD</b>	Yes No	REPLACE cluster. REPLACE Flexible circuit.										
	<ul style="list-style-type: none"> <li>Disconnect battery ground cable.</li> <li>Remove cluster as outlined.</li> <li>Inspect flexible circuit traces (traces are double thick) connected to Circuits 13B and 14B (ground and run circuits)</li> <li>Are traces OK?</li> </ul>												

**PINPOINT TEST TB:  
CLUSTER TOO DIM**

TEST STEP		RESULT	ACTION TO TAKE
<b>TB1</b>	<b>VERIFY CONDITION</b>	Part of cluster dim and part of cluster illumination OK All displays too dim	REPLACE cluster. GO to TB2.
	<ul style="list-style-type: none"> <li>Check to see if part of cluster is dim or all displays are dim.</li> </ul>		
<b>TB2</b>	<b>ENSURE HEADLAMPS ARE OFF</b>	No Yes	TURN headlamps OFF. GO to TB3.
	<ul style="list-style-type: none"> <li>Cluster will dim from 65 percent to almost off with headlamps on.</li> <li>Are headlamps off?</li> </ul>		

## DIAGNOSIS AND TESTING (Continued)

**PINPOINT TEST TB:**  
**CLUSTER TOO DIM (Continued)**

TEST STEP		RESULT	ACTION TO TAKE
<b>TB3</b>	<b>CHECK DIMMER VOLTAGE</b>		
	<ul style="list-style-type: none"> <li>● Disconnect battery ground cable.</li> <li>● Remove cluster as outlined and disconnect Connectors A and B.</li> <li>● Connect battery ground and turn ignition to RUN.</li> <li>● Ensure headlamps are off. Measure dimmer voltage to ground (Connector A, Pin 19).</li> <li>● Is voltage greater than 3 volts?</li> </ul>	No Yes	REPLACE cluster. SERVICE Circuit 19 and dimmer for short to battery or run circuits.

**PINPOINT TEST TC:**  
**DISPLAY SCRAMBLED, SEGMENTS HALF ILLUMINATED (GHOST SEGMENTS), SEGMENTS BLINKING OR MISSING, DISPLAY INCORRECT ALL THE TIME, DISPLAY STUCK WITH ALL SEGMENTS ON.**

TEST STEP		RESULT	ACTION TO TAKE
<b>TC1</b>	<b>VERIFY CONDITION</b>		
	<ul style="list-style-type: none"> <li>● Turn ignition switch from OFF to RUN and observe the display prove out. All segments on one second, all segments off one second followed by a normal display.</li> </ul>	Prove out operates Prove out does not operate properly	System OK. REPLACE cluster.

**PINPOINT TEST TD:**  
**CLUSTER WILL NOT DIM OR DOES NOT DIM PROPERLY**

TEST STEP		RESULT	ACTION TO TAKE
<b>TD1</b>	<b>VERIFY CONDITION</b>		
	<ul style="list-style-type: none"> <li>● Turn ignition to RUN.</li> <li>● Turn headlamps on.</li> <li>● Dimmer should control cluster illumination from 65 percent to almost off.</li> <li>● Does cluster dim properly?</li> </ul>	Yes No	System OK. GO to TD2.
<b>TD2</b>	<b>CHECK DIMMER VOLTAGE</b>		
	<ul style="list-style-type: none"> <li>● Disconnect battery ground cable.</li> <li>● Remove cluster as outlined.</li> <li>● Connect battery ground cable.</li> <li>● Turn ignition to RUN.</li> <li>● Turn headlamps on.</li> <li>● Voltage at Connector A, Pin 13 should vary from 5 volts to battery voltage while operating dimmer.</li> <li>● Does voltage vary within range?</li> </ul>	Yes No	System OK. REPLACE cluster.

**PINPOINT TEST TE:**  
**TEMPERATURE GAUGE DISPLAY BLANKS OUT THERMOMETER SYMBOL AND LIGHTS TOP TWO AND BOTTOM TWO BARS OF GAUGE**

TEST STEP		RESULT	ACTION TO TAKE
<b>TE1</b>	<b>VERIFY CONDITION</b>		
			GO to TE2.
<b>TE2</b>	<b>CHECK FOR TEMPERATURE SENDER SHORT</b>		
	<ul style="list-style-type: none"> <li>● Unplug wire temperature sender.</li> <li>● Turn ignition to RUN.</li> <li>● Temperature gauge should indicate COLD with bottom bar illuminated.</li> </ul>	Temperature gauge indicates as specified Temperature gauge does not indicate as specified	REPLACE temperature sender. GO to TE3.
<b>TE3</b>	<b>CHECK FOR SHORT IN WIRING</b>		
	<ul style="list-style-type: none"> <li>● Disconnect battery ground cable.</li> <li>● Unplug wire temperature sender.</li> <li>● Remove cluster.</li> <li>● Measure resistance between Pin 4A and Pin 8A (GND).</li> </ul>	Resistance greater than 15,000 ohms Resistance less than 15,000 ohms	REPLACE cluster. SERVICE wiring Circuit 39 for shorts.

## DIAGNOSIS AND TESTING (Continued)

**PINPOINT TEST TX:  
NO WARNING TONE WHEN THERMOMETER SYMBOL IS BLINKING**

TEST STEP		RESULT	ACTION TO TAKE
<b>TX1</b>	<b>REVIEW OPERATION / VERIFY CONDITION</b>		
	<ul style="list-style-type: none"> <li>● The gauge driver alert tone is not active until at least 300 rpm or valid oil pressure has been detected, (i.e. vehicle was started).</li> <li>● Warning chime module will not beep if another sound is being produced.</li> <li>● Driver alert only given for temperatures above normal band.</li> </ul>		<ul style="list-style-type: none"> <li>▶ GO to TX2.</li> </ul>
<b>TX2</b>	<b>CHECK WARNING CHIME</b>		
	<ul style="list-style-type: none"> <li>● Turn ignition to RUN.</li> <li>● Press any cluster control button and listen for beep.</li> <li>● Does chime beep?</li> </ul>	<ul style="list-style-type: none"> <li>Yes</li> <li>No</li> </ul>	<ul style="list-style-type: none"> <li>▶ System OK.</li> <li>▶ GO to Pinpoint Test SA.</li> </ul>

**PINPOINT TEST TF:  
TEMPERATURE GAUGE ALWAYS INDICATES COLD TEMPERATURE (BOTTOM BAR ILLUMINATED)**

TEST STEP		RESULT	ACTION TO TAKE
<b>TF1</b>	<b>CHECK TEMPERATURE GAUGE WIRING</b>		
	<ul style="list-style-type: none"> <li>● Unplug connector to temperature sender and connect a jumper to ground in place of sender.</li> <li>● Turn ignition to RUN.</li> <li>● Gauge should give a short circuit indication. Top two and bottom two bars of gauge illuminated.</li> </ul>	<ul style="list-style-type: none"> <li>Top two and bottom two bars illuminate</li> <li>Bars do not illuminate as specified</li> </ul>	<ul style="list-style-type: none"> <li>▶ GO to TF3. REMOVE jumper.</li> <li>▶ GO to TF2.</li> </ul>
<b>TF2</b>	<b>CHECK WIRING AT CLUSTER</b>		
	<ul style="list-style-type: none"> <li>● Disconnect ground cable to battery.</li> <li>● Remove cluster.</li> <li>● Connect jumper in place of temperature sender.</li> <li>● Verify continuity between Pins 4A and 8A of harness.</li> <li>● Is there continuity?</li> </ul>	<ul style="list-style-type: none"> <li>Yes</li> <li>No</li> </ul>	<ul style="list-style-type: none"> <li>▶ REPLACE cluster.</li> <li>▶ SERVICE wiring Circuit 39 and / or temperature sender ground line for open circuit.</li> </ul>
<b>TF3</b>	<b>CHECK SENDER</b>		
	<ul style="list-style-type: none"> <li>● Warm up engine to normal operating temperature.</li> <li>● Measure resistance of temperature sender.</li> </ul>	<ul style="list-style-type: none"> <li>Resistance less than 8,000 ohms</li> <li>Resistance greater than 8,000 ohms</li> </ul>	<ul style="list-style-type: none"> <li>▶ REPLACE cluster.</li> <li>▶ GO to TF4.</li> </ul>
<b>TF4</b>	<b>CHECK COOLING SYSTEM</b>		
	<ul style="list-style-type: none"> <li>● Check thermostat, coolant level, etc. for proper operation.</li> </ul>	<ul style="list-style-type: none"> <li>Cooling system OK</li> <li>Cooling system not OK</li> </ul>	<ul style="list-style-type: none"> <li>▶ REPLACE temperature sender.</li> <li>▶ SERVICE cooling system as required.</li> </ul>

**PINPOINT TEST SA:  
DISPLAY DOES NOT RESPOND TO BUTTONS—NO BEEP WHEN BUTTONS PUSHED OR DRIVER ALERT GIVEN**

TEST STEP		RESULT	ACTION TO TAKE
<b>SA1</b>	<b>VERIFY CONDITION</b>		
	<ul style="list-style-type: none"> <li>● Cluster only responds to buttons when ignition is in RUN.</li> <li>● Warning chime module will not beep if another sound is being produced.</li> </ul>	<ul style="list-style-type: none"> <li>Display does not respond to buttons</li> <li>No beep sounds but display response to buttons / warnings</li> </ul>	<ul style="list-style-type: none"> <li>▶ GO to SA3.</li> <li>▶ GO to SA2.</li> </ul>
<b>SA2</b>	<b>CHECK WARNING CHIME MODULE</b>		
	<ul style="list-style-type: none"> <li>● Check for fasten safety belt reminder chime or key left in ignition reminder chime.</li> <li>● Does chime sound?</li> </ul>	<ul style="list-style-type: none"> <li>Yes</li> <li>No</li> </ul>	<ul style="list-style-type: none"> <li>▶ GO to SA6.</li> <li>▶ SERVICE warning chime module.</li> </ul>

**DIAGNOSIS AND TESTING (Continued)**

**PINPOINT TEST SA:  
DISPLAY DOES NOT RESPOND TO BUTTONS—NO BEEP WHEN BUTTONS PUSHED OR DRIVER ALERT GIVEN  
(Continued)**

TEST STEP		RESULT	ACTION TO TAKE												
<b>SA3</b>	<b>CHECK SWITCH WIRING CONNECTIONS</b>														
	<ul style="list-style-type: none"> <li>Remove finish panel to expose cluster.</li> <li>Verify that connections at switch assembly are securely connected.</li> <li>Are connections secure?</li> </ul>	Yes No	GO to SA4. Secure connections and RECHECK.												
<b>SA4</b>	<b>CHECK SWITCH ASSEMBLY (BUTTON PRESSED)</b>														
	<ul style="list-style-type: none"> <li>Unplug switch assembly from electronic instrument cluster (6-pin connector is located at front face of cluster to the far right).</li> <li>Measure resistance between Pin 2 (Y) and Pin 4 (O) of connector unplugged.</li> <li>The resistance should be:</li> </ul> <table border="1" data-bbox="72 676 749 887"> <thead> <tr> <th>BUTTON</th> <th>RESISTANCE (in ohms)</th> </tr> </thead> <tbody> <tr> <td>E/M</td> <td>4900-5400</td> </tr> <tr> <td>SELECT</td> <td>2200-2400</td> </tr> <tr> <td>SPEED</td> <td>320-360</td> </tr> <tr> <td>RESET</td> <td>980-985</td> </tr> <tr> <td>NO BUTTON PRESSED</td> <td>17000-17800</td> </tr> </tbody> </table> <p>NOTE: Press only one button at a time. Wiggle wire at 6-pin switch connector and at switch module and check for loose connections.</p> <ul style="list-style-type: none"> <li>Is resistance within range?</li> </ul>	BUTTON	RESISTANCE (in ohms)	E/M	4900-5400	SELECT	2200-2400	SPEED	320-360	RESET	980-985	NO BUTTON PRESSED	17000-17800	Yes No	GO to SA5. REPLACE switch assembly.
BUTTON	RESISTANCE (in ohms)														
E/M	4900-5400														
SELECT	2200-2400														
SPEED	320-360														
RESET	980-985														
NO BUTTON PRESSED	17000-17800														
<b>SA5</b>	<b>CHECK CLUSTER WIRING CONNECTIONS</b>														
	<ul style="list-style-type: none"> <li>Visually inspect 6-pin switch connector for poor / damaged or missing connections.</li> </ul>	Cluster pin damaged / missing Switch module pins damaged / missing All pins OK	REPLACE cluster. REPLACE switch module. REPLACE cluster.												
<b>SA6</b>	<b>CHECK TONE CIRCUIT</b>														
	<ul style="list-style-type: none"> <li>Disconnect battery ground cable.</li> <li>Remove cluster.</li> <li>Turn ignition switch to RUN and wait for the fasten safety belt reminder chime to end.</li> <li>Place jumper wire between harness Connector A, Pin 19 and ground. Listen for chime.</li> </ul> <div data-bbox="173 1467 642 1778"> <p align="center"><b>CCA CONNECTOR PLUG A ON EIC</b></p> </div> <p align="right">K16684-A</p> <ul style="list-style-type: none"> <li>Does chime sound?</li> </ul>	Yes No	REPLACE cluster. SERVICE wiring Circuit 183 for open. CHECK for correct warning chime module part number or operation.												



## DIAGNOSIS AND TESTING (Continued)

**PINPOINT TEST SB:  
SPEEDOMETER READS 0 MPH (km/h) AT ALL SPEEDS WHEN VEHICLE IN MOTION**

TEST STEP		RESULT	ACTION TO TAKE
SB1	VERIFY CONDITION		▶ GO to SB2.
SB2	VERIFY DISPLAY PROVE OUT		▶ GO to SB3. ▶ REPLACE cluster. <sup>1</sup>
	<ul style="list-style-type: none"> <li>● Turn ignition switch to RUN.</li> <li>● Observe display (all segments ON, then OFF, and then normal display).</li> <li>● Does display prove out properly?</li> </ul>	Yes No	▶ GO to SB3. ▶ REPLACE cluster. <sup>1</sup>
SB3	CHECK ODOMETER		▶ GO to SB4. ▶ REPLACE cluster. <sup>1</sup>
	<ul style="list-style-type: none"> <li>● Verify that odometer advances when vehicle is driven forward.</li> <li>● Does odometer advance?</li> </ul>	No Yes	▶ GO to SB4. ▶ REPLACE cluster. <sup>1</sup>
SB4	CHECK FUEL COMPUTER		▶ REPLACE cluster. <sup>1</sup> ▶ GO to SB5.
	<ul style="list-style-type: none"> <li>● Test drive vehicle.</li> <li>● Select TRIP DISTANCE on fuel computer.</li> <li>● Distance should advance as vehicle is driven.</li> <li>● Does distance advance?</li> </ul>	Yes No	▶ REPLACE cluster. <sup>1</sup> ▶ GO to SB5.
SB5	CHECK SPEED CONTROL		▶ GO to SB10. ▶ GO to SB6.
	<ul style="list-style-type: none"> <li>● Test drive vehicle and check operation of speed (control, if so equipped).</li> <li>● Does speed control operate properly?</li> </ul>	Yes No	▶ GO to SB10. ▶ GO to SB6.
SB6	CHECK WIRING TO SPEED SENSOR		▶ GO to SB7. ▶ SERVICE wiring Circuit 150, speed control, cluster for shorts.
	<ul style="list-style-type: none"> <li>● Disconnect connector to vehicle speed sensor.</li> <li>● Using Rotunda Digital Volt-Ohmmeter 014-00407 or equivalent, measure the resistance between the two wires in the harness to the vehicle speed sensor.</li> <li>● Resistance should be greater than 500 ohms.</li> <li>● Is resistance greater than 500 ohms?</li> </ul>	Yes No	▶ GO to SB7. ▶ SERVICE wiring Circuit 150, speed control, cluster for shorts.
SB7	CHECK VEHICLE SPEED SENSOR RESISTANCE		▶ GO to SB8. ▶ REPLACE vehicle speed sensor. CHECK speedometer operation.
	<ul style="list-style-type: none"> <li>● Using Rotunda Digital Volt-Ohmmeter 014-00407 or equivalent, measure the resistance between the two wires in the harness to the vehicle speed sensor.</li> <li>● Resistance should be 200 - 230 ohms.</li> <li>● Is resistance within range?</li> </ul>	Yes No	▶ GO to SB8. ▶ REPLACE vehicle speed sensor. CHECK speedometer operation.
SB8	CHECK DRIVEN GEAR AND RETAINER CLIP		▶ GO to SB9. ▶ REPLACE with proper gear and/or clip.
	<ul style="list-style-type: none"> <li>● Disconnect vehicle speed sensor from transmission. Verify presence of driven gear with all teeth in good condition and the presence of retainer clip.</li> <li>● Are driven gear and retainer clip OK?</li> </ul>	Drive gear / clip OK Drive gear / clip not OK	▶ GO to SB9. ▶ REPLACE with proper gear and/or clip.
SB9	CHECK DRIVE GEAR ON TRANSMISSION		▶ GO to SB10. ▶ SERVICE gear.
	<ul style="list-style-type: none"> <li>● Verify presence of drive gear on transaxle output shaft.</li> <li>● Is drive gear OK?</li> </ul>	Drive gear present Drive gear not present	▶ GO to SB10. ▶ SERVICE gear.
SB10	CHECK WIRING TO CLUSTER		▶ REPLACE cluster. <sup>1</sup> ▶ SERVICE connectors / wiring from cluster to vehicle speed sensor Circuit 150. CHECK speedometer operation.
	<ul style="list-style-type: none"> <li>● Reconnect vehicle speed sensor wiring.</li> <li>● Disconnect battery ground cable.</li> <li>● Remove cluster as outlined.</li> <li>● Using Rotunda Digital Volt-Ohmmeter 014-00407 or equivalent, measure the resistance between Pins 12 and 8 (ground) of Connector A.</li> <li>● Resistance should be 160 - 230 ohms.</li> <li>● Is resistance within range?</li> </ul>	Resistance between 160 and 230 ohms Resistance not as specified	▶ REPLACE cluster. <sup>1</sup> ▶ SERVICE connectors / wiring from cluster to vehicle speed sensor Circuit 150. CHECK speedometer operation.

<sup>1</sup> Affix odometer sticker to door pillar.

## DIAGNOSIS AND TESTING (Continued)

**PINPOINT TEST SC:  
SPEEDOMETER READS CONSTANTLY TOO HIGH OR LOW**

TEST STEP		RESULT	ACTION TO TAKE
SC1	VERIFY CONDITION		▶ GO to SC2.
SC2	CHECK ODOMETER ACCURACY		
	<ul style="list-style-type: none"> <li>Over a known distance, compare the odometer reading with the distance traveled.</li> </ul>	Odometer accurate Odometer not accurate	▶ System OK. ▶ GO to SC3.
SC3	CHECK VEHICLE SPEED SENSOR DRIVE GEAR		
	<ul style="list-style-type: none"> <li>Remove vehicle speed sensor from transmission and verify that correct drive gear is installed for vehicle transmission / axle / tire combination.</li> </ul>	Correct gear installed Incorrect gear installed	▶ GO to SC4. ▶ INSTALL correct gear with retaining clip.
SC4	CHECK DRIVE GEAR ON TRANSMISSION OUTPUT SHAFT		
	<ul style="list-style-type: none"> <li>Check that correct drive gear is installed on transaxle output shaft.</li> </ul>	Correct gear installed Incorrect gear installed	▶ REPLACE cluster module. <sup>2</sup> ▶ INSTALL correct shaft / gear.

**PINPOINT TEST SD:  
SPEED INDICATION JUMPS UP AND DOWN ERRATICALLY**

TEST STEP		RESULT	ACTION TO TAKE
SD1	VERIFY CONDITION		▶ GO to SD2.
SD2	CHECK VEHICLE SPEED SENSOR DRIVE GEAR		
	<ul style="list-style-type: none"> <li>Remove vehicle speed sensor from transmission.</li> <li>Check that all gear teeth are in good condition, retainer clip is installed and gear does not slip on shaft.</li> </ul>	Gear / clip OK Gear / clip not OK	▶ GO to SD3. ▶ REPLACE drive gear and / or retaining clip.
SD3	CHECK WIRING TO VEHICLE SPEED SENSOR		
	<ul style="list-style-type: none"> <li>Disconnect connector to vehicle speed sensor.</li> <li>Using Rotunda Digital Volt Ohmmeter 014-00407 or equivalent, check for intermittent resistance between the two wires in the harness to the vehicle speed sensor.</li> <li>Resistance should be greater than 500 ohms.</li> </ul>	Resistance greater than 500 ohms Resistance less than 500 ohms	▶ GO to SD4. ▶ SERVICE wiring Circuit 150, speed control for intermittent shorts or opens. CHECK speedometer operation.
SD4	CHECK VEHICLE SPEED SENSOR RESISTANCE		
	<ul style="list-style-type: none"> <li>Using Rotunda Digital Volt Ohmmeter 014-00407 or equivalent, check for intermittent resistance at vehicle speed sensor.</li> <li>Resistance should be 200-230 ohms.</li> </ul>	Resistance between 200 and 230 ohms Resistance not as specified	▶ GO to SD5. ▶ REPLACE vehicle speed sensor. CHECK speedometer operation.
SD5	CHECK WIRING TO CLUSTER		
	<ul style="list-style-type: none"> <li>Reconnect vehicle speed sensor wiring.</li> <li>Disconnect battery ground cable.</li> <li>Remove cluster.</li> <li>Using Rotunda Digital Volt-Ohmmeter 014-00407 or equivalent, measure the resistance between Pin 12 and 8 (ground) of Connector A.</li> <li>Resistance should be between 200 and 300 ohms.</li> </ul>	Resistance constant Resistance intermittent	▶ REPLACE cluster. <sup>2</sup> ▶ SERVICE connectors / wiring from cluster to vehicle speed sensor Circuit 150. CHECK speedometer operation.

<sup>2</sup> Affix odometer sticker to door pillar.

**DIAGNOSIS AND TESTING (Continued)**

**PINPOINT TEST SE:  
ODOMETER DISPLAY READS "ERROR" AND SERVICE SYMBOL ON**

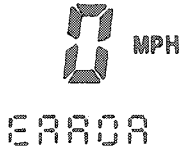
TEST STEP		RESULT	ACTION TO TAKE
SE1	VERIFY CONDITION		
 <p>K16688-A</p>			REPLACE cluster.

**PINPOINT TEST SF:  
DISPLAY HAS "S" ILLUMINATED**

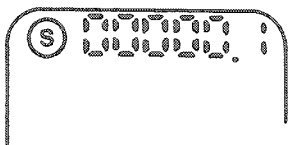
TEST STEP		RESULT	ACTION TO TAKE
SF1	VERIFY CONDITION		
 <p>K16689-A</p>			GO to SF2.
SF2	DETERMINE IF SPEEDO/ODO MODULE IS ORIGINAL		
<ul style="list-style-type: none"> <li>● Check for mileage sticker on door pillar.</li> <li>● Is module original?</li> </ul>		Original	Display damaged. REPLACE cluster. S should be illuminated and odometer should indicate zero miles.
		Replacement	System OK. Label on door pillar should indicate mileage at which the replacement cluster was installed.

**PINPOINT TEST SG:  
ODOMETER DOES NOT ACCUMULATE MILEAGE, OR COUNTS 16 KM (10 MILES) AND JUMPS BACK 16 KM (10 MILES)**

TEST STEP		RESULT	ACTION TO TAKE
SG1	VERIFY CONDITION		
		Odometer will not accumulate	GO to SG1.
		Odometer accumulates 16 Km (10 miles), then loses 16 Km (10 miles)	REPLACE cluster.
SG2	VERIFY SPEEDOMETER		
<ul style="list-style-type: none"> <li>● Verify that speedometer works properly.</li> <li>● Does speedometer operate properly?</li> </ul>		Yes	REPLACE cluster.
		No	GO to Pinpoint Test SB.

## DIAGNOSIS AND TESTING (Continued)

**PINPOINT TEST SH:  
ODOMETER READING INCORRECT**

TEST STEP		RESULT	ACTION TO TAKE
SH1	VERIFY CONDITION		
	<ul style="list-style-type: none"> <li>● Enter self-diagnosis as outlined.</li> <li>● Does cluster flash?</li> </ul>	No	REPLACE cluster.
		Yes	GO to Pinpoint Test SB1.

**PINPOINT TEST SJ:  
MILEAGE CONSTANTLY READS TOO HIGH OR LOW**

TEST STEP		RESULT	ACTION TO TAKE
SJ1	VERIFY CONDITION		
			GO to SJ2.
SJ2	CHECK SPEEDOMETER		
	<ul style="list-style-type: none"> <li>● Perform Pinpoint Test SC.</li> <li>● Is system OK?</li> </ul>	Yes	GO to SJ3.
		No	GO to Pinpoint Test SC.
SJ3	CHECK DISPLAY		
	<ul style="list-style-type: none"> <li>● Perform Pinpoint Test TB.</li> <li>● Is system OK?</li> </ul>	Yes	GO to SJ4.
		No	GO to Pinpoint Test TB.
SJ4	CHECK ODOMETER MEMORY		
	<ul style="list-style-type: none"> <li>● Perform Pinpoint Test SH.</li> <li>● Is system OK?</li> </ul>	Yes	System OK
		No	GO to Pinpoint Test SH.

**PINPOINT TEST SK:  
TACH ALWAYS INDICATES TOO HIGH OR TOO LOW—NO TACH INDICATION/TACH INDICATION ERRATIC**

TEST STEP		RESULT	ACTION TO TAKE
SK1	VERIFY CONDITION		
	<ul style="list-style-type: none"> <li>● Make sure engine is operating properly and is not misfiring.</li> </ul>		GO to SK2.
SK2	CHECK WIRING		
	<ul style="list-style-type: none"> <li>● Disconnect battery ground cable.</li> <li>● Remove cluster as outlined.</li> <li>● Measure resistance between Connector A, Pin 20 and coil.</li> <li>● Wiggle connections and wiring near coil to check for intermittent connection.</li> <li>● Is resistance less than 100 ohms?</li> </ul>	Yes	REPLACE cluster. RECHECK operation.
		No	SERVICE wiring Circuit 11 for open circuit.

**PINPOINT TEST FA:  
INSTANTANEOUS FUEL ECONOMY ALWAYS READ 0 MILES/GAL OR 99 L/100 KM OR 99 MILES/GAS OR 0 L/100 KM**

TEST STEP		RESULT	ACTION TO TAKE
FA1	VERIFY CONDITION		
			GO to FA2.
FA2	CHECK SPEEDOMETER OPERATION		
	<ul style="list-style-type: none"> <li>● Verify that speedometer is operating properly.</li> <li>● Does speedometer operate properly?</li> </ul>	Yes	GO to FA3.
		No	GO to Pinpoint Test SF.
FA3	CHECK CONTINUITY OF CIRCUIT 305 (FUEL FLOW)		
	<ul style="list-style-type: none"> <li>● Verify continuity and absence of shorts in Circuit 305.</li> </ul>	Continuity and no shorts	GO to Pinpoint Test FD4.
		No continuity and/or shorts	SERVICE wiring Circuit 305 as required.
FA4	CHECK FOR FUEL FLOW PULSES		
	<ul style="list-style-type: none"> <li>● Verify proper operation of fuel flow function in PCM. Refer to Powertrain Control/Emissions Diagnosis Manual.<sup>3</sup></li> <li>● Does fuel flow operate properly?</li> </ul>	Yes	REPLACE EIC.
		No	SERVICE or REPLACE EIC or fuel flow sensor system as required.

<sup>3</sup> Can be purchased as a separate item.

## DIAGNOSIS AND TESTING (Continued)

**PINPOINT TEST FB:  
TRIP DISTANCE DOES NOT ACCUMULATE**

TEST STEP		RESULT	ACTION TO TAKE
FB1	VERIFY CONDITION		GO to FB2.
FB2	CHECK SPEEDOMETER OPERATION		
	<ul style="list-style-type: none"> <li>● Verify that speedometer is operating properly.</li> <li>● Does speedometer operate properly?</li> </ul>	Yes No	REPLACE cluster. GO to Pinpoint Test SF.

**PINPOINT TEST FC:  
DTE DOES NOT GO BELOW 322 KM (200 MILES) WITH FUEL TANK EMPTY  
DTE ALWAYS READS ZERO**

TEST STEP		RESULT	ACTION TO TAKE
FC1	VERIFY CONDITION		GO to FC2.
FC2	CHECK FUEL GAUGE		
	<ul style="list-style-type: none"> <li>● Verify that fuel gauge is operating properly.</li> <li>● Does fuel gauge operate properly?</li> </ul>	Yes No	GO to FC3. GO to Pinpoint Test FD or FE.
FC3	CHECK SPEEDOMETER		
	<ul style="list-style-type: none"> <li>● Verify that speedometer is operating properly.</li> <li>● Does speedometer operate properly?</li> </ul>	Yes No	GO to FC4. GO to Pinpoint Test SB.
FC4	CHECK FOR FUEL FLOW PULSES		
	<ul style="list-style-type: none"> <li>● Verify proper operation of fuel flow function in PCM. Refer to Powertrain Control/Emissions Diagnosis Manual.<sup>4</sup></li> </ul>	Yes No	REPLACE EIC. SERVICE or REPLACE PCM or fuel flow sensor system as required.

**PINPOINT TEST FD:  
CO DISPLAYED, GAUGE BLANKS OUT FUEL TANK SYMBOL AND LIGHTS TOP TWO AND BOTTOM TWO BARS OF GAUGE**

TEST STEP		RESULT	ACTION TO TAKE
FD1	VERIFY CONDITION		
	<ul style="list-style-type: none"> <li>● Does CO display?</li> </ul>	Yes	GO to FD2.
FD2	CHECK FUEL TANK SENDING UNIT AND PUMP WIRING AT FUEL TANK SENDING UNIT AND PUMP		
	<ul style="list-style-type: none"> <li>● Disconnect ground cable to battery.</li> <li>● Lower fuel tank to gain access to fuel tank sending unit and pump connector.</li> <li>● Unplug fuel sender connector.</li> <li>● Jumper variable resistance terminal and ground terminal of harness together.</li> <li>● Reconnect battery.</li> <li>● Turn ignition switch from OFF to RUN.</li> <li>● Check digital fuel remaining display for CO or CS.</li> </ul> <p>NOTE: It may take several minutes for the fuel gauge to respond.</p>	CO displayed CS displayed	GO to FD4. GO to FD3. REMOVE jumper.
FD3	CHECK FUEL TANK SENDING UNIT AND PUMP		
	<ul style="list-style-type: none"> <li>● Turn ignition switch to OFF.</li> <li>● Measure the resistance of the fuel tank sending unit and pump at the sender terminals.</li> <li>● Verify that the resistance is between 11 and 168 ohms.</li> </ul>	Resistance between 11 and 168 ohms  Resistance not as specified	INSPECT fuel tank sending unit and pump wiring connector female terminals for flash or loose fit. SERVICE as required.  REPLACE fuel tank sending unit and pump.

<sup>4</sup> Can be purchased as a separate item.

## DIAGNOSIS AND TESTING (Continued)

## PINPOINT TEST FD:

CO DISPLAYED, GAUGE BLANKS OUT FUEL TANK SYMBOL AND LIGHTS TOP TWO AND BOTTOM TWO BARS OF GAUGE  
(Continued)

TEST STEP		RESULT	ACTION TO TAKE
FD4	CHECK FUEL TANK SENDING UNIT AND PUMP WIRING AT CLUSTER		
	<ul style="list-style-type: none"> <li>Disconnect ground cable to battery.</li> <li>Remove cluster and secure connectors from shorting.</li> <li>Jumper variable resistance terminal and ground terminal of harness together at sender.</li> <li>Verify condition between Pins 6 and 8 (ground) of cluster Connector A.</li> </ul>	Yes	REPLACE cluster. AFFIX odometer sticker to door pillar.
		No	SERVICE fuel tank sending unit and pump wiring for open circuit.

## PINPOINT TEST FE:

CS DISPLAYED, GAUGE BLANKS OUT TANK SYMBOL AND LIGHTS TOP TWO AND BOTTOM TWO BARS OF GAUGE

TEST STEP		RESULT	ACTION TO TAKE
FE1	VERIFY CONDITION		
	<ul style="list-style-type: none"> <li>Does CS display?</li> </ul>	Yes	GO to FE2.
FE2	CHECK FUEL TANK SENDING UNIT AND PUMP WIRING AT CLUSTER		
	<ul style="list-style-type: none"> <li>Disconnect ground cable to battery.</li> <li>Remove cluster and secure connectors from shorting.</li> <li>With an ohmmeter, measure resistance between Pins 6A and 8A (SIG GND) of harness.</li> <li>Verify that the resistance is 11 ohms or greater (normally 11 to 168 ohms).</li> <li>Is resistance at least 11 ohms?</li> </ul>	Resistance between 11 and 168 ohms	REPLACE cluster. <sup>5</sup>
		Resistance not as specified	Short exists in harness or fuel tank sending unit and pump. GO to FE3.
FE3	CHECK FUEL TANK SENDING UNIT AND PUMP WIRING		
	<ul style="list-style-type: none"> <li>Disconnect ground cable to battery.</li> <li>Lower fuel tank to gain access to fuel tank sending unit and pump connector.</li> <li>Unplug connector to fuel tank sending unit and pump.</li> <li>Measure resistance between Pins 6 and 8 (GND) of harness Connector A.</li> <li>Verify that resistance is greater than 10,000 ohms.</li> </ul>	Resistance between 11 and 168 ohms	REPLACE fuel tank sending unit and pump.
		Resistance not as specified	SERVICE fuel tank sending unit and pump wiring for short circuit.

## PINPOINT TEST FF:

INACCURATE FUEL INDICATION—FULL NOT INDICATED WHEN FUEL TANK IS FULL—EMPTY NOT INDICATED WHEN FUEL TANK IS EMPTY

TEST STEP		RESULT	ACTION TO TAKE
FF1	VERIFY CONDITION		
			GO to FF2.
FF2	CHECK FUEL GAUGE RESPONSE		
	<ul style="list-style-type: none"> <li>Disconnect ground cable to battery.</li> <li>Lower fuel tank (if necessary) to gain access to fuel tank sending unit and pump connections.</li> <li>Connect a 43 ohm (<math>\pm</math> 1 percent) resistor in place of fuel tank sending unit and pump. Verify resistance of resistor prior to test.</li> <li>Reconnect battery.</li> <li>Turn ignition key to RUN.</li> <li>Fuel gauge should illuminate 2 to 3 bars.</li> <li>Fuel remaining should read 13 to 15L (3 to 4 gal).</li> <li>Does gauge read properly?</li> </ul>	Yes	GO to FF4. TURN ignition OFF.
		No	GO to FF3. TURN ignition OFF.

5 Affix odometer sticker to door pillar.



## DIAGNOSIS AND TESTING (Continued)

**PINPOINT TEST FF:**  
**INACCURATE FUEL INDICATION — FULL NOT INDICATED WHEN FUEL TANK IS FULL — EMPTY NOT INDICATED WHEN FUEL TANK IS EMPTY (Continued)**

TEST STEP		RESULT	ACTION TO TAKE
FF3	CHECK HARNESS RESISTANCE		
	<ul style="list-style-type: none"> <li>● Disconnect ground cable to battery.</li> <li>● Remove cluster and secure connectors from shorting.</li> <li>● With a 43 ohm resistor in place of fuel sender, measure resistance between Pins 6 and 8 of Connector A.</li> </ul>	42-45 ohms Not between 42 and 45 ohms	REPLACE cluster. SERVICE Circuit 29 as required.
FF4	CHECK FUEL TANK SENDING UNIT AND PUMP		
	<ul style="list-style-type: none"> <li>● Disconnect ground cable to battery.</li> <li>● Check fuel tank sending unit and pump for binding, sticking, misalignment, etc.</li> <li>● Is sender OK?</li> </ul>	Yes No	GO to FF5. SERVICE or REPLACE fuel tank sending unit and pump as required.
FF5	CHECK FUEL TANK		
	<ul style="list-style-type: none"> <li>● Check fuel tank for dents, bulges or other damage.</li> <li>● Check for proper installation of fuel tube.</li> <li>● Are fuel tank or fuel tube OK?</li> </ul>	Yes No	GO to FF6. REPLACE fuel tank or fuel tube.
FF6	CHECK FUEL VAPOR SYSTEM		
	<ul style="list-style-type: none"> <li>● Check for blockage of fuel tank vapor valve, tubing or carbon canister. Refer to Section 10-00.</li> <li>● Is system OK?</li> </ul>	Yes No	System OK. Fault caused by other vehicle system. SERVICE or REPLACE as required.

**PINPOINT TEST FG: DOOR AJAR WARNING NEVER / ALWAYS COMES ON**

TEST STEP		RESULT	ACTION TO TAKE
FG1	VERIFY CONDITION		
		Always on Never on	GO to FG2. GO to FG4.
FG2	CHECK SWITCHES		
	<ul style="list-style-type: none"> <li>● The following steps are to be repeated for each door ajar switch. Start with the drivers door, then front passenger, then rear passengers.</li> <li>● Turn ignition switch to OFF. This resets the warning.</li> <li>● Pull connector off of the door ajar switch.</li> <li>● Turn ignition switch to RUN.</li> <li>● Check message center for warning.</li> <li>● Repeat until no warning is displayed or all door switches are disconnected.</li> <li>● Is warning still displayed?</li> </ul>	Yes No	GO to FG3. SERVICE the last switch tested.
FG3	CHECK CIRCUIT 627 (BK/O)		
	<ul style="list-style-type: none"> <li>● Turn ignition switch to OFF.</li> <li>● Remove electronic instrument cluster.</li> <li>● Check continuity between Pins 17 and 8 of Connector A.</li> <li>● Is there continuity?</li> </ul>	No Yes	REPLACE cluster. <sup>6</sup> SERVICE Circuit 627 (BK/O) for short.
FG4	CHECK SWITCH		
	<ul style="list-style-type: none"> <li>● Turn ignition switch to OFF.</li> <li>● Pull connector off of the problem door ajar switch.</li> <li>● Connect a jumper wire from Circuit 627 (BK/O) at the harness connector to ground.</li> <li>● Turn ignition switch to RUN.</li> <li>● Check message center for warning.</li> <li>● Is warning displayed?</li> </ul>	Yes No	SERVICE door ajar switch. GO to FG5.

<sup>6</sup> Affix odometer sticker to door pillar.

## DIAGNOSIS AND TESTING (Continued)

## PINPOINT TEST FG: DOOR AJAR WARNING NEVER/ALWAYS COMES ON (Continued)

TEST STEP		RESULT	ACTION TO TAKE
FG5	CHECK WIRING		
	<ul style="list-style-type: none"> <li>● Leave jumper wire connected as in FG3.</li> <li>● Turn ignition switch to OFF.</li> <li>● Remove electronic instrument cluster.</li> <li>● Check continuity between Pins 17 and 8 of Connector A.</li> <li>● Is there continuity?</li> </ul>	Yes No	REPLACE EIC. SERVICE Circuit 627 (BK/O) for open.

PINPOINT TEST FP:  
WASHER FLUID NEVER ILLUMINATES OR ILLUMINATED AT ALL TIMES

TEST STEP		RESULT	ACTION TO TAKE
FP1	VERIFY CONDITION		
	<ul style="list-style-type: none"> <li>● Warning never on. Drain fluid from reservoir.</li> <li>● Warning on at all times. Fill reservoir.</li> <li>● Turn ignition to RUN and actuate wiper/washer switch.</li> <li>● Check system scanner for washer fluid warnings.</li> </ul>	Warning never on Warning on at all times Warning always illuminates when washer fluid is used	GO to FP2. GO to FP6. GO to FP7.
FP2	CHECK SENSOR		
	<ul style="list-style-type: none"> <li>● Ensure washer fluid is drained from reservoir.</li> <li>● Disconnect electrical connector from windshield washer fluid sensor.</li> <li>● Check sensor for continuity.</li> <li>● Is there continuity?</li> </ul>	No Yes	REPLACE sensor. GO to FP3.
FP3	SENSOR VOLTAGE CHECK		
	<ul style="list-style-type: none"> <li>● Reconnect sensor.</li> <li>● Turn ignition to RUN and actuate wiper/washer switch.</li> <li>● Measure voltage (with respect to ground) at wiper washer fluid sensor.</li> <li>● Is voltage greater than 9 volts?</li> </ul>	No Yes	TEST wiper/washer switch. Refer to Section 11-05. CHECK for an open between sensor and switch. GO to FP4.
FP4	CHECK FOR INTERMITTENT CONNECTION AT CLUSTER		
	<ul style="list-style-type: none"> <li>● Remove cluster from dash. Do not disconnect.</li> <li>● Turn ignition to RUN and actuate wiper switch.</li> <li>● With wiper switch activated, wiggle Connector B and check connection.</li> <li>● Is connection intermittent?</li> </ul>	Yes No	SERVICE Connector B or flexible circuit on cluster. GO to FP5.
FP5	CHECK VOLTAGE AT CLUSTER		
	<ul style="list-style-type: none"> <li>● Remove cluster as outlined.</li> <li>● Turn ignition to RUN.</li> <li>● Actuate washer fluid switch and measure voltage at Connector B, Pin 15 to ground.</li> <li>● Is voltage greater than 9 volts?</li> </ul>	No Yes	CHECK Circuit 298 for an open or short. REPLACE cluster.
FP6	CHECK VOLTAGE AT CLUSTER		
	<ul style="list-style-type: none"> <li>● Remove cluster as outlined.</li> <li>● Turn ignition to RUN and measure voltage at connector B, Pin 15 to ground.</li> <li>● Is voltage greater than 3 volts?</li> </ul>	No Yes	REPLACE cluster. CHECK Circuit 298 for a short to battery or run circuits.
FP7	CHECK SENSOR		
	<ul style="list-style-type: none"> <li>● Ensure reservoir is full.</li> <li>● Disconnect electrical connector and windshield washer fluid reservoir.</li> <li>● Check continuity across sensor.</li> <li>● Is there continuity?</li> </ul>	No Yes	CHECK for an open or short in Circuit 941. REPLACE sensor.

**DIAGNOSIS AND TESTING (Continued)**

**PINPOINT TEST FI:  
HEADLAMP, REAR LAMP OUT WARNING ALWAYS ON**

TEST STEP		RESULT	ACTION TO TAKE
F11	VERIFY CONDITION		▶ GO to F12.
F12	CHECK EXTERIOR BULBS		
	<ul style="list-style-type: none"> <li>● Check low beam headlamp bulbs.</li> <li>● Check brake lamp bulbs.</li> <li>● Check rear park lamp bulbs.</li> <li>● Are bulbs OK?</li> </ul>	Yes No	▶ GO to F13. ▶ SERVICE bulbs.
F13	CHECK LAMP OUTAGE MODULE INPUT TO ELECTRONIC INSTRUMENT CLUSTER		
	<ul style="list-style-type: none"> <li>● Disconnect lamp outage module from wiring harness. (Refer to Section 13-09 for location and removal procedure.)</li> <li>● Turn ignition switch to RUN.</li> <li>● Does warning message remain on?</li> </ul>	Yes No	▶ GO to F14. ▶ GO to Section 13-09 to troubleshoot lamp outage module.
F14	CHECK FOR SHORT TO GROUND IN ELECTRONIC CLUSTER HARNESS		
	<ul style="list-style-type: none"> <li>● With lamp outage module disconnected, disconnect electronic instrument cluster.</li> <li>● Turn ignition switch to RUN.</li> <li>● Check continuity between Ground, Pin 8, Circuit 563 (O/Y) and the "Headlamp Out" warning, Pin 3 (130 R/LG) on the cluster harness connector.</li> <li>● Check continuity between Ground, Pin 8 (563 O/Y) and the "Rear Lamp Out" warning, Pin 5 (125 Y/R).</li> <li>● Check continuity between Ground, Pin 8 (563 O/W) and the "Rear Lamp Out" warning, Pin 5 (135 Y/R).</li> </ul> <p><b>Electronic Instrument Cluster Harness Connector</b></p>	Yes No	▶ SERVICE circuit shorted to ground. ▶ REPLACE electronic instrument cluster.

K18675-A

- Is there continuity?

**PINPOINT TEST FJ:  
"CHECK LOW OIL" LEVEL WARNING IS ALWAYS ON**

TEST STEP		RESULT	ACTION TO TAKE
FJ1	VERIFY CONDITION		▶ GO to FJ2.
FJ2	CHECK TIME-OUT		
	<ul style="list-style-type: none"> <li>● Park vehicle on level surface.</li> <li>● Check engine oil level with dipstick. Fill to FULL mark with proper motor oil.</li> <li>● Turn ignition switch to OFF.</li> <li>● Wait for more than two minutes.</li> <li>● Turn ignition switch to RUN.</li> <li>● Check messages for oil level warning.</li> <li>● Is warning displayed?</li> </ul>	Yes No	▶ GO to FJ3. ▶ System operating properly.

## DIAGNOSIS AND TESTING (Continued)

**PINPOINT TEST FJ:**  
**“CHECK LOW OIL” LEVEL WARNING IS ALWAYS ON (Continued)**

TEST STEP		RESULT	ACTION TO TAKE
<b>FJ3</b>	<b>CHECK SENSOR</b>		
	<ul style="list-style-type: none"> <li>● Turn ignition switch to OFF.</li> <li>● Disconnect wire from oil level sensor.</li> <li>● Wait for more than two minutes.</li> <li>● Turn ignition switch to RUN.</li> <li>● Check messages for oil level warning.</li> <li>● Is warning displayed?</li> </ul>	Yes No	GO to FJ4. SERVICE oil level sensor.
<b>FJ4</b>	<b>CHECK WIRING</b>		
	<ul style="list-style-type: none"> <li>● Remove electronic instrument cluster.</li> <li>● Disconnect wire from oil level sensor.</li> <li>● Measure resistance from electronic instrument cluster harness Connector A, Pin 14 to Connector A, Pin 8 or ground.</li> <li>● Circuit should be open.</li> <li>● Is circuit open?</li> </ul>	Yes No	REPLACE cluster. SERVICE Circuit 258 (W/PK) for short.

## REMOVAL AND INSTALLATION

**Cluster Assembly**

Federal law requires that the odometer in any replacement speedometer/odometer must register the same mileage as that registered on the removed speedometer/odometer. Service replacement speedometer/odometers and odometer modules with the mileage preset to actual vehicle mileage are available through Ford Electronic Service Centers. In nearly all instances, the mileage continues to accumulate in the odometer memory even if the odometer does not display mileage. This mileage can usually be verified by the electronic service centers. Contact the service center for instructions to receive a replacement speedometer/odometer or odometer module with the mileage preset to actual mileage.

If the actual vehicle mileage cannot be verified, the service center will supply a speedometer/odometer or odometer module with the odometer display preset to zero (“0”) miles and the service odometer segment “S” illuminated in the vicinity of the odometer display. In addition, an odometer mileage sticker is supplied with the replacement odometer. This sticker must display the estimated vehicle mileage and is to be affixed to the driver’s door.

**Removal**

1. Disconnect battery ground cable.
2. Remove two lower trim covers.
3. Remove steering column cover and disconnect two screws retaining PRNDL cable to cluster.
4. Remove cluster trim panel.

NOTE: Switch module must be disconnected from cluster to remove trim panel.

5. Remove four cluster retaining screws.
6. Pull bottom of cluster toward steering wheel.

7. Reaching behind and underneath cluster, disconnect three connectors.
8. Swing bottom of cluster out to clear top of cluster from crash pad and remove cluster.

**Installation**

1. Insert top of cluster under crash pad, leaving bottom out.
2. Connect three connectors.
3. Seat cluster and install four retaining screws.
4. Connect battery ground cable and check cluster operation.
5. Connect PRNDL. Check PRNDL dial alignment and adjust if necessary. Install steering column cover.
6. Connect switch module to cluster and install cluster trim panel.
7. Install two lower trim covers.

**Mask Assembly****Removal**

1. Remove instrument cluster as outlined.
2. Set cluster on clean surface facing up.
3. Remove warning indicator bulbs.  
NOTE: Mask will not remove from backplate unless bulbs are removed.
4. Remove five screws retaining mask to backplate.
5. Disconnect switch connector from backplate and remove mask.

**Installation**

1. Insert switch connector into mask.
2. Place mask on backplate and install five retaining screws.

**REMOVAL AND INSTALLATION (Continued)**

3. Install warning indicator bulbs.
4. Install cluster as outlined.

**Switch Module****Removal**

1. Remove two lower trim covers.
2. Remove cluster trim panel.  
NOTE: Switch module must be disconnected from cluster to remove trim panel.
3. Remove two switch module retaining screws and remove switch module.

**Installation**

1. Mount switch module to trim panel and install two retaining screws.
2. Connect switch module to cluster and install cluster trim panel.
3. Install two lower trim covers.
4. Test switch module with cluster illuminated.

**Vehicle Speed Sensor**

Refer to Section 10-03.

**Fuel Lines****Tools Required:**

- EFI-CFI Fuel Pressure Gauge T80L-9974-B

**WARNING: FUEL SUPPLY LINES WILL REMAIN PRESSURIZED FOR LONG PERIODS OF TIME AFTER ENGINE SHUTDOWN.**

This pressure must be relieved before servicing the fuel system. A valve is provided on the fuel rail assembly for this purpose. Attach EFI-CFI Fuel Pressure Gauge T80L-9974-B to fuel diagnostic valve on fuel rail assembly. Pressure in fuel system may now be released.

**Fuel Pump and Sender Unit Assembly****Tools Required:**

- Rotunda Fuel Storage Tanker 034-00002
- Rotunda Fuel Storage Tanker Adapter Hose 034-00012
- Fuel/Tank Sender Wrench T86T-9275-A

**Removal**

1. Place vehicle on hoist. Do not raise.
2. Depressurize fuel system as outlined.
3. Remove fuel from fuel tank using Rotunda Fuel Storage Tanker 034-00002 and Adapter Hose 034-00012 or equivalent.
4. Raise vehicle on hoist. Refer to Section 00-02.
5. Remove fuel tube. Remove fuel tank support strap (9092) band fasteners nearest front of vehicle. Carefully lower front of fuel tank and disconnect fuel and fuel tank vent tube (9A086) and electrical connector. Remove fuel tank to bench.
6. Remove dirt that has accumulated around fuel pump and fuel tank sending unit and pump so dirt will not enter tank.
7. Turn fuel pump locking retainer ring (9C385) counterclockwise using Fuel Tank Sender Wrench T86T-9275-A. Remove locking ring, fuel pump and fuel tank sending unit and pump assembly.

## REMOVAL AND INSTALLATION (Continued)

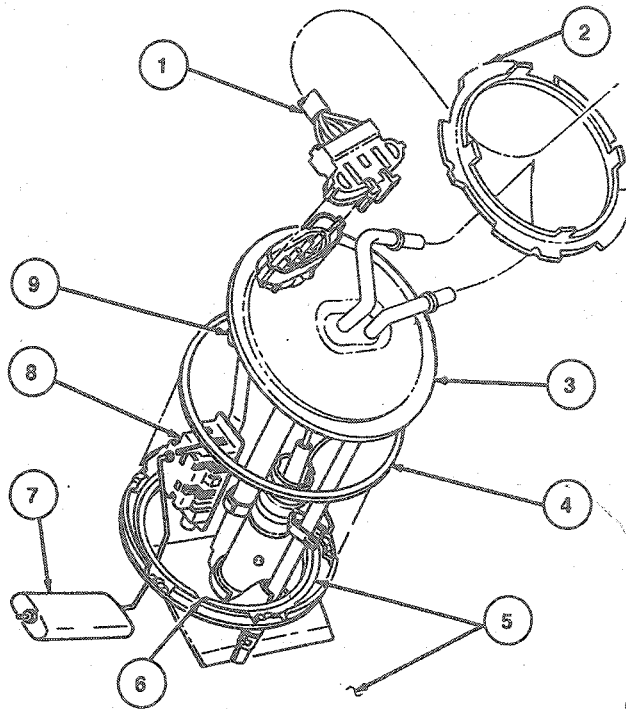
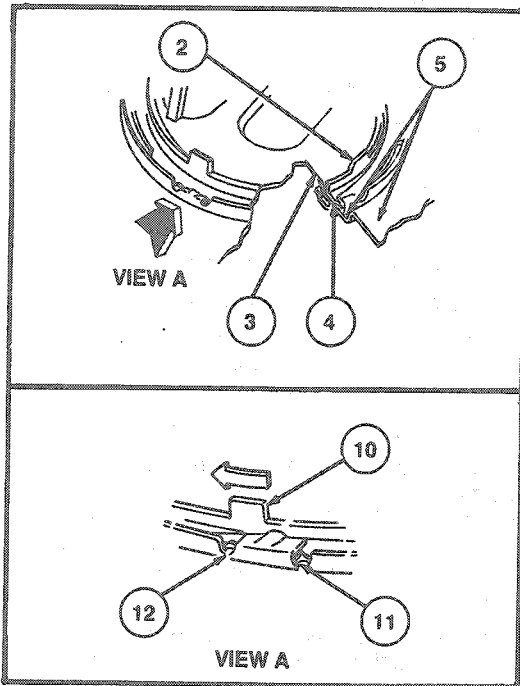

K8945-D

Item	Part Number	Description
1	14405	Wiring Harness Assembly
2	9C385	Locking Ring
3	9H307	Fuel Tank Sending Unit and Pump
4	N803861-S	O-Ring
5	—	Retainer Ring, Part of 9002 Fuel Tank
6	—	Locking Slots

(Continued)

Item	Part Number	Description
7	—	Float, Part of 9H307 Fuel Tank Sending Unit and Pump
8	—	Variable Resistor, Part of 9H307 Fuel Tank Sending Unit and Pump
9	—	Locking Tabs
10	—	Locating Tab
11	—	Stop
12	—	Detent

TK8945D

**Installation**

- Clean fuel tank sending unit and pump mounting surface at fuel tank.
- Apply a light coating of Premium Long-Life Grease XG-1-C (ESA-M1C75-B) or equivalent on a new seal ring and install seal ring and fuel tank sending unit and pump assembly. Secure by rotating locking ring clockwise against stop. Ensure seal remains in place.
- Support fuel tank under vehicle and connect fuel and vent lines and electrical connector.
- Install fuel tank. Secure fuel tank support strap.
- Install fuel tube. Fill fuel tank with a minimum of 38 L (10 gal) of fuel.
- Turn ignition switch to ON then OFF at three second intervals (with EFI-CFI Fuel Pressure Gauge T80L-9974-B or equivalent), until fuel pressure builds to 270 kPa (30 psi).

- Start vehicle, check fuel gauge operation and check for fuel leaks.

**Electronic Low Fuel Warning Assembly****Removal and Installation**

- Remove instrument cluster as outlined.
- Remove screw retaining assembly to cluster and remove assembly.
- To install, position assembly on cluster and install retaining screw. Tighten screw to 0.8-1.4 N-m (8-12 lb-in).
- Install instrument cluster as outlined in Section 13-00.



## REMOVAL AND INSTALLATION (Continued)

## Oil Pressure Switch

## 3.0L Multiport Fuel Injection (MFI) Engine

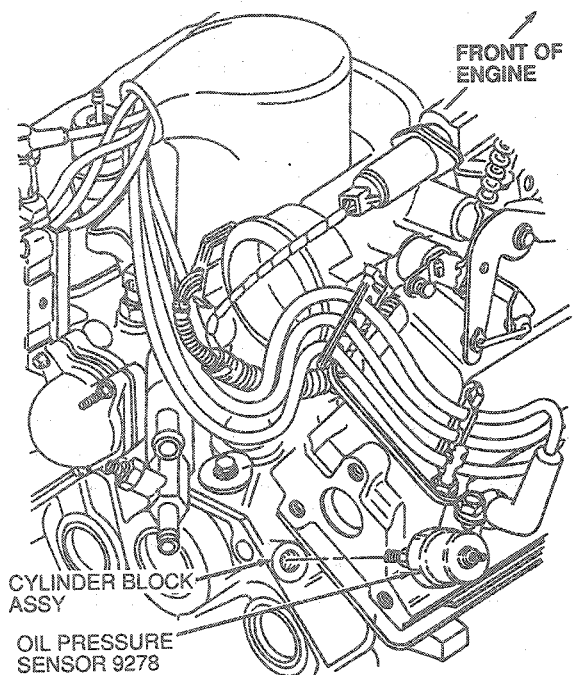

CYLINDER BLOCK ASSY

OIL PRESSURE SENSOR 9278  
TIGHTEN TO  
16-22 N·m (12-16 LB-FT)

K14880-B

## 3.8L MFI Engine

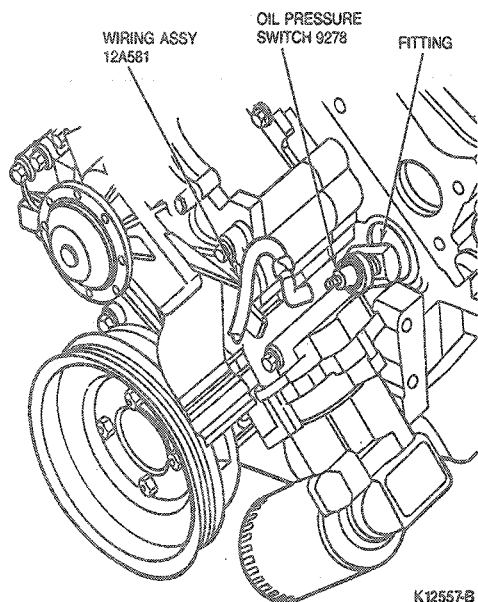

K12557-B

**CAUTION:** Installation of the wrong part will result in an inoperative oil pressure indicating system and a damaged sender unit or gauge.

The pressure switch-type unit used with the warning indicator systems is not interchangeable with the variable resistance-type unit used with the gauge system. Refer to the Master Parts catalog for proper parts usage.

## 3.0L Engine

## Tool Required:

- Remover / Replacer Tool 87L-9278-A

## Removal and Installation

1. Disconnect wire at oil pressure sender (9278) and remove oil pressure sender using Removal / Replacer Tool T87L-9278-A.
2. To install oil pressure sender, coat threads with Pipe Sealant with Teflon® D8AZ-19554-A (ESG-M4G194-A) or equivalent and install in fitting.
3. Tighten oil pressure sender to 19 N·m (14 lb-ft) using Removal / Replacer Tool T87L-9278-A.
4. Install electrical connector to switch.
5. Start engine and check for oil leaks.

## 3.8L Engine

## Tool Required:

- Remover / Replacer Tool 87L-9278-A

## Removal

1. Remove washer solvent / coolant recovery bottle.
2. Release drive belt tension and position drive belt aside.
3. Remove belt idler pulley below power steering pump.
4. Disconnect wire from oil pressure sender and remove oil pressure sender using Removal / Replacer Tool T87L-9278-A.

## Installation

1. Apply Pipe Sealant with Teflon® D8AZ-19554-A (ESG-M4G194-A) or equivalent to threads of oil pressure sender. Install oil pressure sender using Removal / Replacer Tool T87L-9278-A. Tighten to 11-24 N·m (9-17 lb-ft).
2. Install idler pulley. Tighten bolt to 70-95 N·m (52-70 lb-ft).
3. Install drive belt.
4. Install washer solvent / coolant recovery bottle. Top off fluids.
5. Start engine and check for leaks.

## SPECIFICATIONS



## TORQUE SPECIFICATIONS

Description	N-m	Lb-Ft
Cluster Retaining Screw	0.8-1.4	8-12 (Lb-in)
Oil Pressure Switch 3.0L MFI	19	14
Oil Pressure Switch 3.8L	11-24	9-17
Idler Pulley Bolt	70-95	52-70

## ROTUNDA EQUIPMENT

Model	Description
014-00407	Digital Volt-Ohmmeter
034-00002	Fuel Storage Tanker
034-00012	Fuel Storage Tanker Adapter Hose

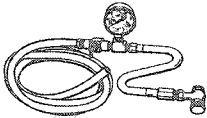
## SPECIAL SERVICE TOOLS

Tool Number/ Description	Illustration
T80L-9974-B EFI-CFI Fuel Pressure Gauge	 T80L-9974-B
T86T-9275-A Fuel Tank Sender Wrench	 T86T-9275-A
T87L-9278-A Removal/Replacer Tool	 T87L-9278-A

## PARTS CROSS-REFERENCE

Base Part #	Part Name	Old Part Name
9002	Fuel Tank	
9092	Fuel Tank Support Strap	
9278	Oil Pressure Sender	
9280	Fuel Gauge	
9291	Fuel Tube	
9A086	Fuel Tank Vent Tube	
9C385	Fuel Pump Locking Retainer Ring	
9H307	Fuel Tank Sending Unit and Pump	