



SPECIFICATIONS

COMPRESSOR SPECIFICATIONS



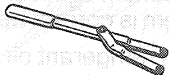

Description	Specification
TYPE	SWASHPLATE, 5 DOUBLE ACTING PISTONS — AXIAL TYPE
DISPLACEMENT	10.4 CID (170cc)
CYLINDER BORE (Dia.)	29.0mm
STROKE	25.7mm
ROTATION	CLOCKWISE
ROTATIONAL TORQUE (Maximum, manifold removed)	10 N·m — (7 Lb·Ft)
REFRIGERANT OIL Ford Specification	ESH-M2C31-A2
Capacity (System Total)	207 ml (7 ounces) 295 ml (10 ounces) with auxiliary A/C
Part Number	E73Z-19577-A Motorcraft YN-9
MAGNETIC CLUTCH Air Gap Between Pulley and Hub	0.45mm-0.85mm (0.018-0.033 Inch)
Current Draw	4.36 Amps @ 12.8 volts
Run-Out (Maximum)	0.02 Inch-Radial or Axial
TORQUE LIMITS Hose & Manifold Assy. to Compressor Bolt	18-23 N·m (13-17 Lb·Ft)
Clutch Hub Bolt	11-13 N·m (8-10 Lb·Ft)

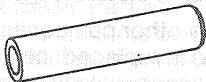
TL8142A

SPECIAL SERVICE TOOLS

Tool Number / Description	Illustration
T70P-4067-A Spanner Wrench	 T70P-4067-A
T71P-19703-C O-Ring Tool	 T71P-19703-C
T89P-19623-AH Seal Installer Tool	 T89P-19623-AH

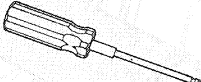
(Continued)

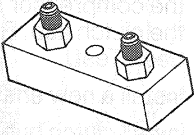
Tool Number / Description	Illustration
T89P-19623-BH Shaft Seal Remover Tool	 T89P-19623-BH
T89P-19623-CH Shaft Protector Tool	 T89P-19623-CH
T89P-19623-DH Snap Ring Remover	 T89P-19623-DH
T89P-19623-EH Coil Pressing (Installer) Tool	 T89P-19623-EH
T89P-19623-FH Shaft Protector Tool	 T89P-19623-FH
T89P-19623-H Pressure Test Fitting Tool	 T89P-19623-H

Tool Number	Description
D80L-1002-L	2-Jaw Puller

ROTUNDA EQUIPMENT

Model	Description
055-00015	Electronic Leak Detector