

MAJOR SERVICE OPERATIONS (Continued)

Cylinder Bolt Tightening Sequence

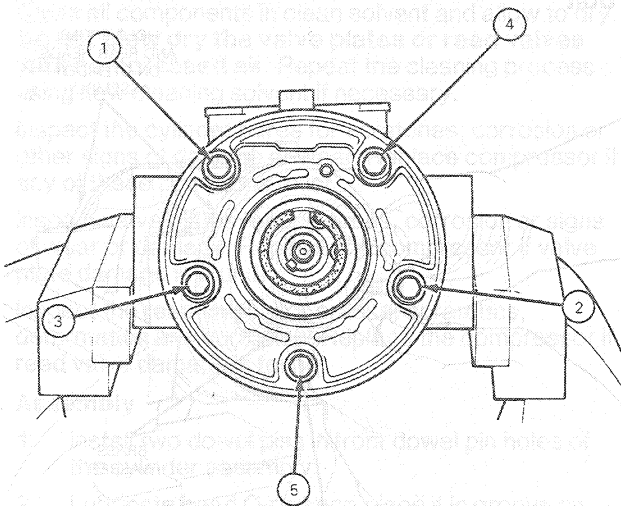

CCL 3393-A

15. Lubricate new shaft seal with clean refrigerant oil and carefully attach shaft seal to Shaft Seal Remover / Replacer T87P-19623-C.

NOTE: DO NOT TOUCH the sealing surface of the shaft seal or seal seat with bare hands. To do so will damage the sealing surface.

16. Place Shaft Seal Protector T71P-19703-H over end of compressor shaft.

NOTE: Check the thin edge of the shaft seal protector for burrs or other damage. Replace the tool if burrs are found as the burrs could damage the internal sealing portion of the shaft seal assembly during installation.

Shaft Seal Protector Installed

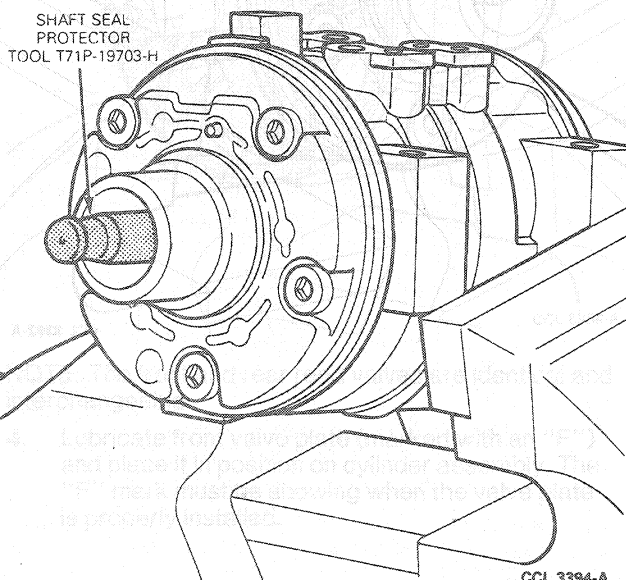

CCL 3394-A

17. Using Shaft Seal Remover / Replacer T87P-19623-C insert shaft seal into compressor. Rotate seal on compressor shaft while pushing inward until flats of shaft are aligned with flats of shaft seal and seal is positioned against stops on shaft.

Shaft Seal—Installation

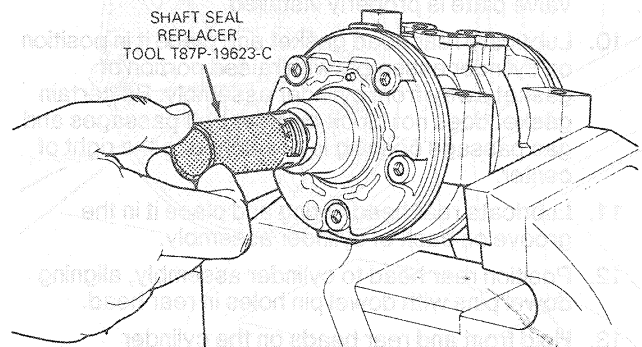

CCL 3395-A

18. Attach shaft seal seat to Shaft Seal Seat Remover T87P-19623-BR and lubricate seat with clean refrigerant oil. Then insert seal seat into compressor. Push seal seat in against the seal.

Shaft Seal Seat—Installation

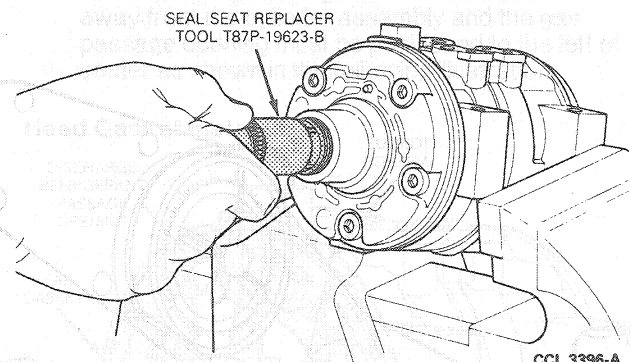

CCL 3396-A

19. Install seal seat retaining snap ring into nose of compressor and push snap ring into the groove with handle end of Shaft Seal Remover / Replacer T87P-19623-C.

Pushing Seal Seat Snap Ring into Groove

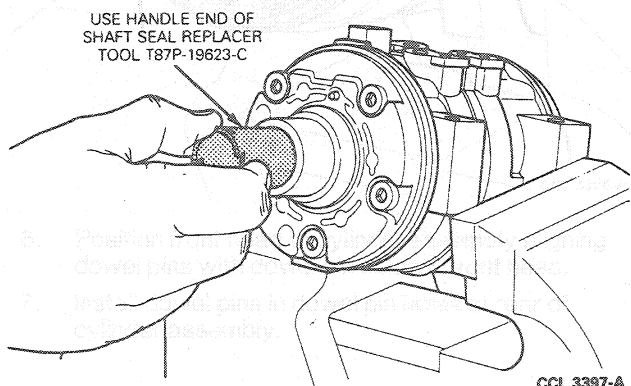

CCL 3397-A