

REMOVAL AND INSTALLATION (Continued)

Shaft Seal Seat Removal

SEAL SEAT REPLACER
TOOL T87P-19623-B

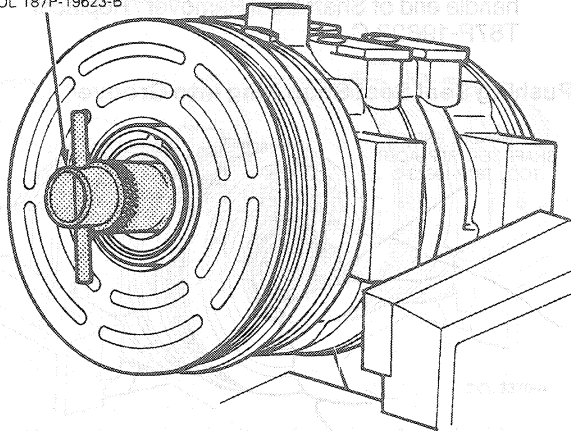

CCL 3378-A

8. Insert Shaft Seal Remover T91P-19623-AA into compressor nose opening on top of shaft seal. Turn tool 45 degrees while pushing tool inward until tool engages tangs of seal. Then pull shaft seal from compressor with tool.

Shaft Seal Removal

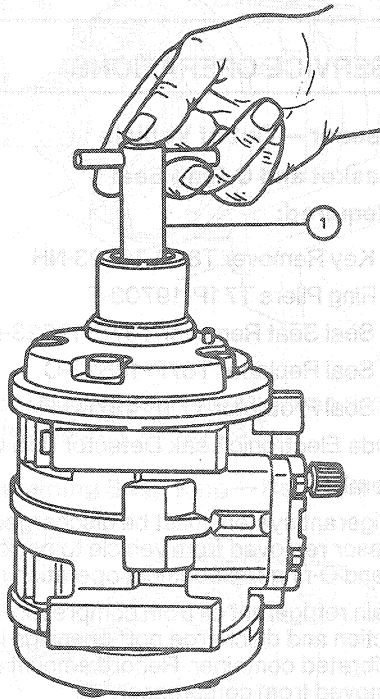

ITEM DESCRIPTION
1. SHAFT SEAL REMOVER - T91P-19623-AA

CCL 3711-A

Installation

1. Place Shaft Seal Protector T71P-19703-H over the compressor shaft.
2. Lubricate new shaft seal with clean refrigerant oil and place it on protector.

NOTE: DO NOT TOUCH the sealing surface of the shaft seal or seal seat with bare hands. To do so will damage the sealing surface.

NOTE: Check the thin edge of the shaft seal protector for burrs or other damage. Replace the tool if burrs are found as the burrs could damage the internal sealing portion of the shaft seal assembly during installation.

Shaft Seal Protector Installed

SHAFT SEAL PROTECTOR
TOOL T71P-19703-H

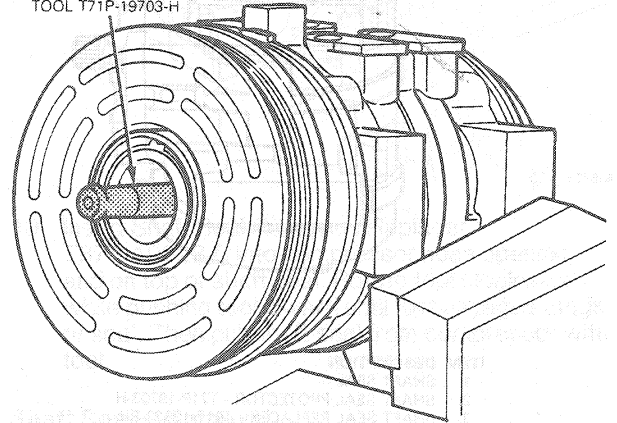

CCL 3380-A

3. Using Shaft Seal Replacer T92P-19623-BH insert the shaft seal into compressor. Rotate seal on compressor shaft while pushing inward until the flats of the shaft are aligned with flats of the shaft seal and the seal is positioned against the stops on the shaft.