

REMOVAL AND INSTALLATION (Continued)

Drilling Holes in Evaporator Case Tabs

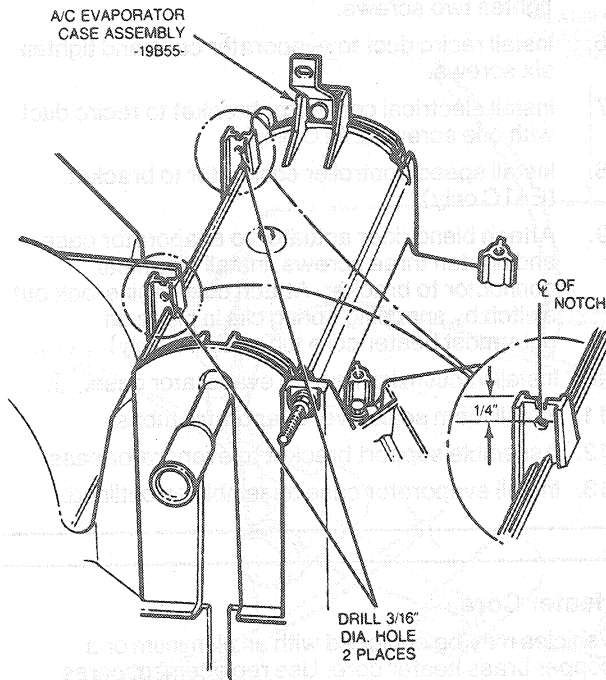

CCL2618-B

- Using a hot knife or small saw blade, cut top of evaporator case between raised outline.

Evaporator Case Cutting

NOTE: CUT 1/16" BEYOND HINGE LINE AT BOTH HINGE LINE ENDS.

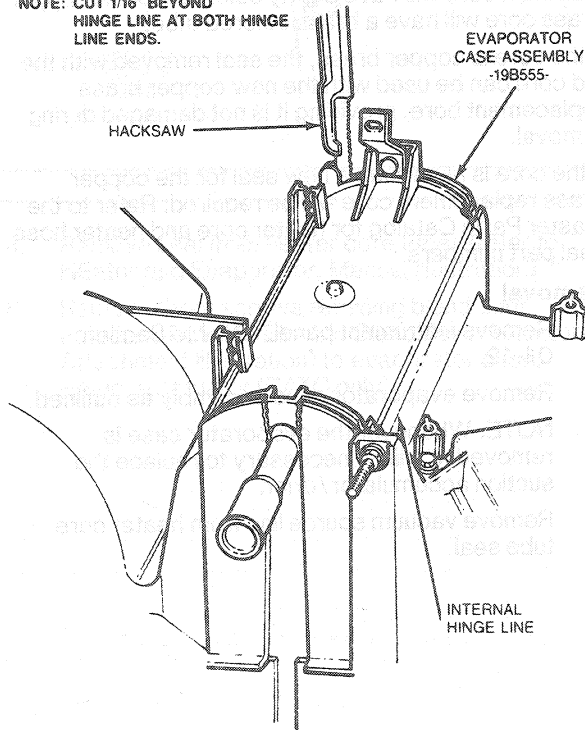

CCL2619-B

- Fold cutout cover back from opening and lift evaporator core from case.

Evaporator Core Removal from Case

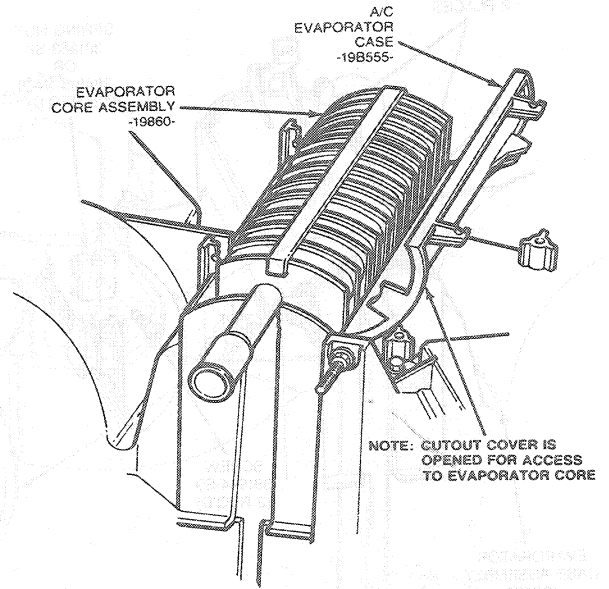

CCL2620-B

Installation

- Transfer two foam core seals to new evaporator core.
- Position evaporator core in case and close cutout cover.
- Install a spring nut on each of two upright tabs with two holes drilled in front flange. Ensure hole in spring nut is aligned with 4.75mm (3/16 inch) holes drilled in tab and flange. Install and tighten screw in each spring nut (through hole in tab or flange) to secure cutout cover in closed position.