

DIAGNOSIS AND TESTING (Continued)

INTEGRAL CONNECTOR

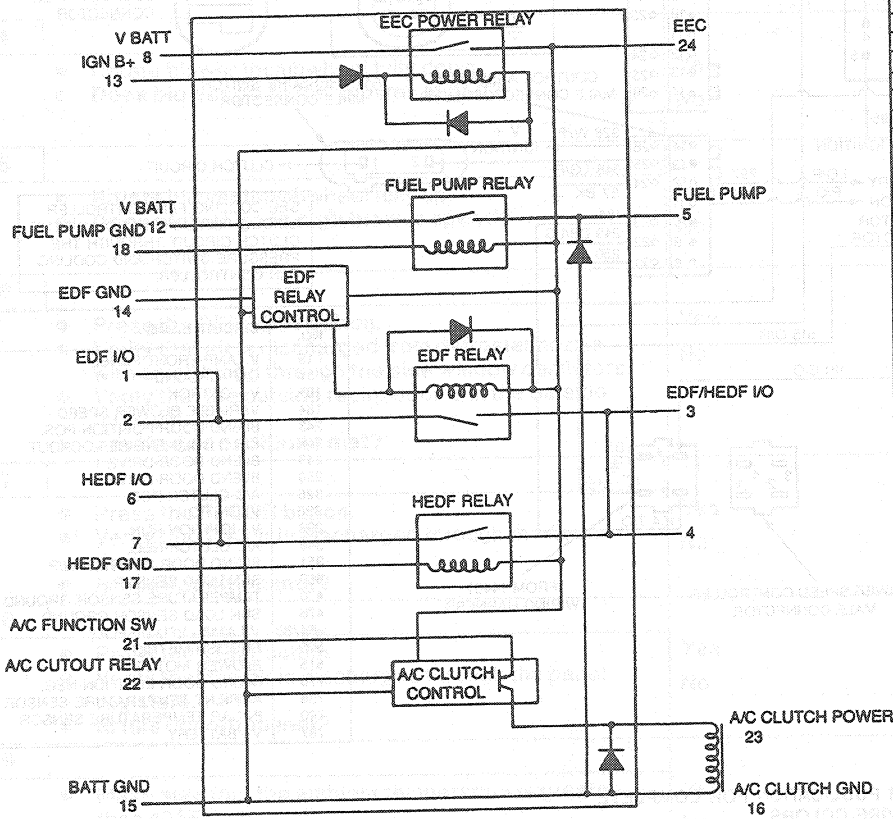
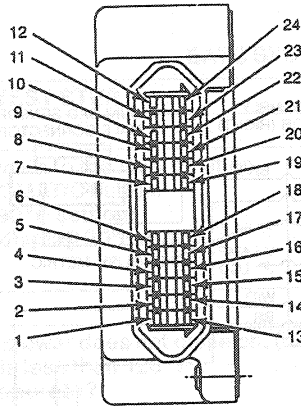

TERM NO.	FUNCTION
1	EDF I/O-1
2	EDF I/O-1
3	HEDF/EDF I/O
4	HEDF/EDF I/O
5	FUEL PUMP
6	HEDF I/O 2
7	HEDF I/O 2
8	V BATT
9	EOL TEST
10	N.C.
11	N.C.
12	FUEL PUMP BATT
13	IGN B+
14	EDF GND
15	BATT GND
16	A/C GND
17	HEDF GND
18	FUEL PUMP GND
19	EOL TEST
20	EOL TEST
21	A/C FUNCTION
22	A/C CUTOUT RELAY*
23	A/C CLUTCH
24	EEC PWR

* WIDE OPEN THROTTLE-A/C CONTROL SWITCH

NOTE: REFER TO THE EVTM PUBLICATION FOR COMPLETE CIRCUIT SCHEMATIC AND WIRE COLORS.

CCL 3770-A