

DESCRIPTION AND OPERATION (Continued)

R-12 System High Pressure Gauge Port Valve Adapters

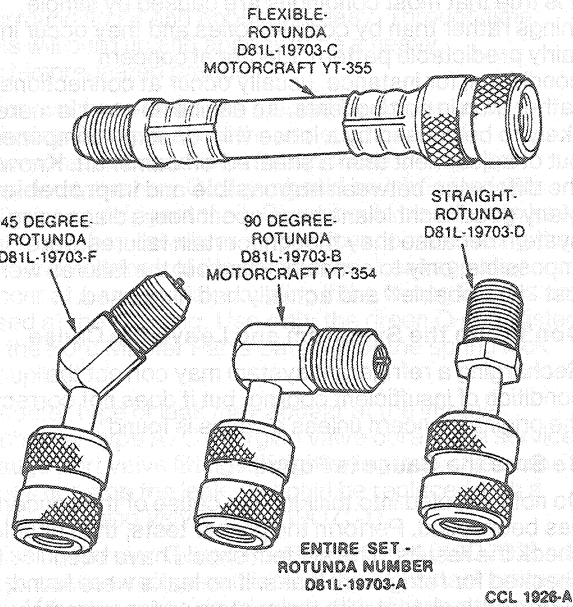

Tee-Type Service Adapter Tool D87P-19703-A or equivalent may be used when diagnosing the low-pressure side of the R-12 refrigerant system.

Tee Adapter Tool Installation

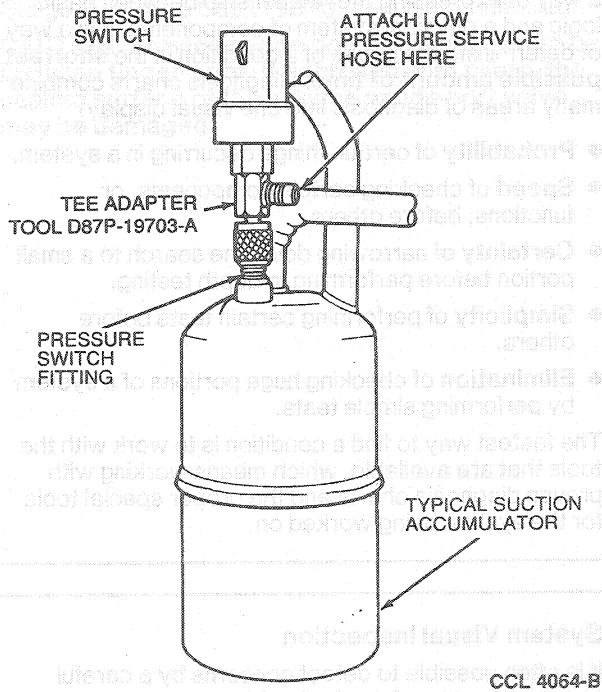

A service gauge port valve assembly is shown in the following illustration with the valve in the closed position. The next illustration shows a gauge port valve in the open position with a manifold gauge set hose attached.

R-12 System Service Gauge Port Valve

