

SECTION 12-03C Compressor and Clutch—FX-15

SUBJECT	PAGE	SUBJECT	PAGE
DESCRIPTION AND OPERATION		REMOVAL AND INSTALLATION	
FX-15 Compressor	12-03C-1	Clutch Field Coil	12-03C-6
DIAGNOSIS AND TESTING		Clutch Hub and Pulley	12-03C-4
Compressor External Leak Test	12-03C-2	Compressor	12-03C-3
Compressor Manifold Leak Test	12-03C-2	Manifold and Hose Assembly	12-03C-4
Compressor Rotating Torque Check	12-03C-3	Shaft Seal	12-03C-7
MAINTENANCE		SPECIAL SERVICE TOOLS	12-03C-11
Adding Refrigerant Oil	12-03C-10	SPECIFICATIONS	12-03C-11
		VEHICLE APPLICATION	12-03C-1

VEHICLE APPLICATION

Taurus / Sable with 3.0L and 3.8L engines.

DESCRIPTION AND OPERATION

FX-15 Compressor

The FX-15 is a swashplate design ten-cylinder aluminum compressor utilizing the tangential design mount. The compressor mainshaft is driven by a belt from the engine crankshaft pulley. A one-piece lip-type seal (replaceable from the front of the compressor) is used to seal it at the shaft opening in the assembly. Five double-acting pistons, positioned axially around the compressor shaft, operate within the cylinder assembly. The pistons are actuated by a swashplate that is pressed on the compressor shaft. The swashplate changes the rotating action of the shaft to provide a reciprocating driving force to each of the five pistons. This driving force is applied, through shoes, to the midpoint of each of the double end pistons.

Reed-type discharge valves are assembled on the valve plate which is located with the suction reed valve between the cylinder assembly and the head at each end of the compressor. The heads are connected to each other by gas-tight passageways through the cylinder assembly which direct the refrigerant gas to the suction and discharge ports located in the rear head.

A magnetic clutch is used to drive the compressor shaft. When voltage is applied to the clutch field coil, the clutch plate and hub assembly (which is solidly coupled to the compressor shaft) is drawn rearward by magnetic force toward the pulley which rotates freely on the compressor front head casting. The magnetic force locks the clutch plate and hub assembly and the pulley together as one unit. The compressor shaft then turns with the pulley. When voltage is removed from the clutch field coil, springs in the clutch plate and hub assembly move the clutch plate away from the pulley. The clutch plate hub assembly and compressor shaft cease to rotate.

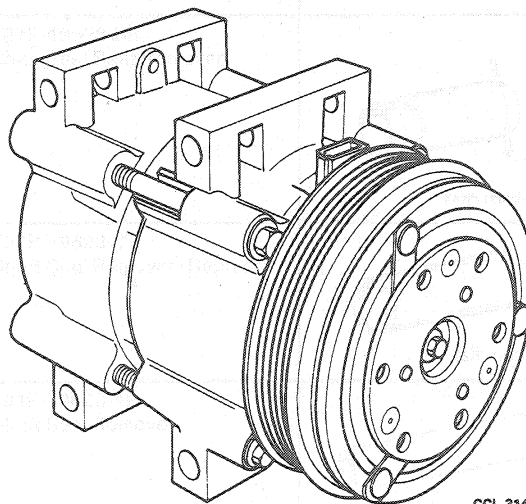

DIAGNOSIS AND TESTING

Compressor Manifold Leak Test**Tools Required:**

- Rotunda Electronic Leak Detector 005-00015
1. Tighten the manifold retaining bolt to 18-23 N·m (13-17 lb-ft).
 2. Add refrigerant to the system if necessary.
 3. Leak test the manifold O-ring seals using Rotunda Electronic Leak Detector 055-00015 or equivalent.
 4. If no leaks are found, the manifold O-ring seals are good.
 5. If a leak is found at the manifold and the manifold attaching bolt is tightened to 18-23 N·m (13-17 lb-ft), install new manifold O-ring seals as outlined. Then, repeat the leak test.

Compressor External Leak Test**Tools Required:**

- Rotunda Electronic Leak Detector 005-00015
 - Pressure Test Plate T89P-19623-H
1. If the compressor is on the vehicle, discharge the system. Refer to Section 12-00. Remove the compressor from the vehicle. Observe all safety precautions.
 2. Remove the manifold retaining bolt and remove the manifold from the rear head of the compressor. Install Pressure Test Adapter T89P-19623-H on the rear head of the compressor using the existing manifold attaching bolt.

3. Connect the high and low pressure lines of a manifold gauge set to the corresponding fittings on the Manifold Pressure Test Adapter.
4. Attach the center hose of the manifold gauge set to a refrigerant container standing in an upright position.
5. Using the clutch hub, hand-rotate the compressor shaft ten revolutions to distribute the oil inside the compressor.
6. Open the low pressure gauge valve, the high pressure gauge valve and the valve on the refrigerant container to allow the refrigerant vapor to flow into the compressor.
7. Using Rotunda Electronic Leak Detector 055-00015 or equivalent check for leaks at the compressor shaft seal and the compressor center seal.
8. If a shaft seal leak is found, install a new shaft seal as described in this section. If an external leak is found at the center joint of the compressor, install a new compressor assembly.
9. When the leak test is completed, close the manifold gauge valves (both high and low) as well as the valve on the refrigerant container.
10. Slowly remove the gauge set hoses from the pressure test fitting tool. (Allow the refrigerant to escape from the compressor).
11. Install the compressor on the vehicle.
12. Leak test, evacuate and charge the system. Refer to Section 12-00. Observe all safety precautions.

DIAGNOSIS AND TESTING (Continued)

Connecting Gauge Set to Check for Leaks

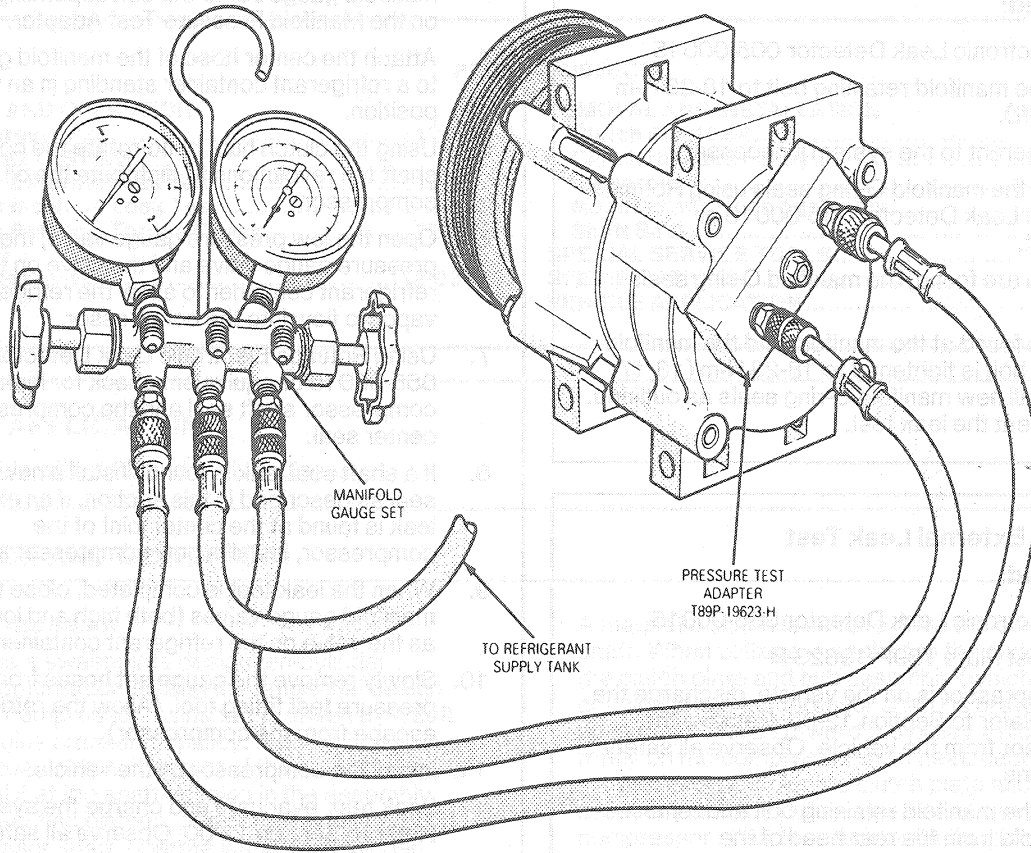

Compressor Rotating Torque Check

The rotational torque of a used compressor should be checked if excessive compressor drag is suspected.

1. Discharge refrigerant system. Refer to Section 12-00. Observe all safety precautions.
2. Remove refrigerant hose and manifold assembly from compressor. Use care not to allow dirt to enter compressor.
3. Remove the compressor from the vehicle. With the compressor clutch disengaged, rotate the compressor shaft and note the torque required to rotate the shaft one complete revolution. This is not the starting torque.
4. If the rotational torque exceeds 10 N·m (7 lb-ft) replace the compressor assembly.

5. If the rotational torque is less than specified, excessive drag does not exist in the compressor. Install the manifold and hose assembly and leak test, evacuate and charge the system.
6. Check the system for proper operation.

REMOVAL AND INSTALLATION

Compressor

Removal and Installation

Refer to Section 12-03A.

REMOVAL AND INSTALLATION (Continued)

Manifold and Hose Assembly

Removal

1. Discharge the refrigerant from the system. Refer to Section 12-00. Remove bolt attaching manifold and hose / tube assembly to the rear head of the compressor.

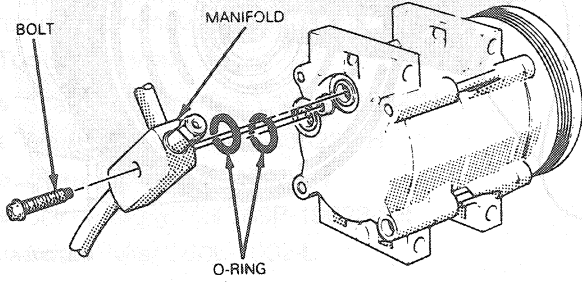

CCL 3303-A

2. Disconnect other ends of suction and discharge lines. Remove any bracket attachments and remove manifold and nose / tube assembly from vehicle.

Installation

1. Lubricate new O-rings with clean refrigerant oil and position them in the O-ring grooves of the compressor rear head.
2. Position manifold and hose / tube assembly to rear head of compressor making sure manifold pilots are positioned in compressor port openings. Install manifold attaching bolt and tighten bolt to 18-23 N·m (13-17 lb-ft).
3. Connect other ends of suction and discharge lines using new lubricated O-rings. Install bracket attachments disconnected during removal.
4. Leak test, evacuate and charge the system. Refer to Section 12-00. Observe all safety precautions.

Clutch Hub and Pulley

A disassembled view of the clutch assembly and related parts is shown in the illustration.

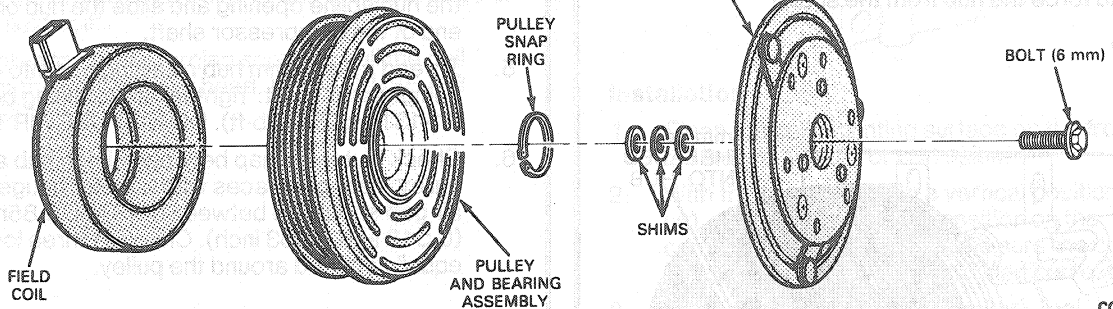

CCL 3304-C

Tools Required:

- Spanner Wrench T70P-4067-A
- Snap Ring Remover T89P-19623-DH

REMOVAL AND INSTALLATION (Continued)

Removal

1. Remove the clutch hub retaining bolt. Use Spanner Wrench T70P-4067-A.

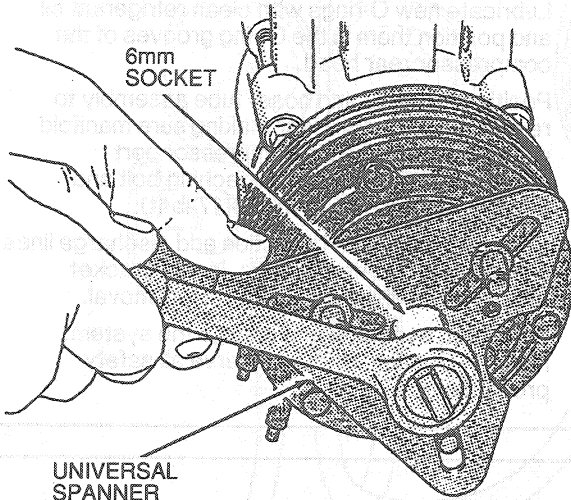

6mm
SOCKET

UNIVERSAL
SPANNER
WRENCH
HOLDING HUB

L8307-A

2. Pull clutch hub and shims from compressor shaft. If hub cannot be pulled from compressor shaft, screw a 6mm bolt into the shaft hole of the clutch hub to force the hub from the shaft.

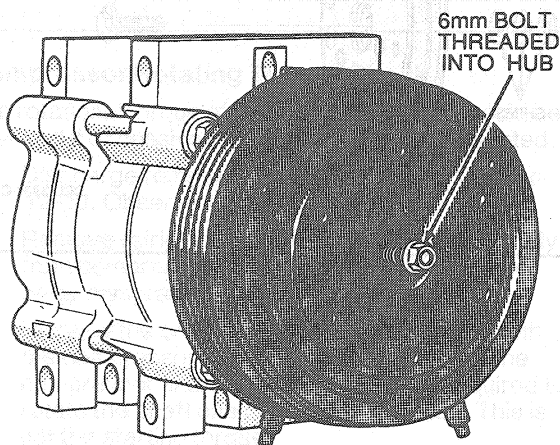

6mm BOLT
THREADED
INTO HUB

L8308-A

3. Remove pulley retaining snap ring.
4. Pull the pulley and bearing assembly from compressor.

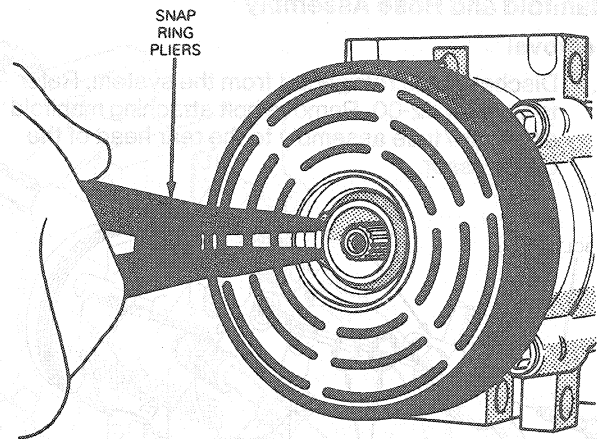

CCL 3307-A

Installation

1. Clean pulley bearing surface of compressor head to remove any dirt or corrosion.
2. Install pulley and bearing assembly on compressor. The bearing is a slip-fit on the compressor head and, if properly aligned, it should slip on easily.
3. Install pulley retaining snap ring with bevel side of snap ring out.
4. Place one nominal thickness spacer shim inside the hub spline opening and slide the hub on the end of the compressor shaft.
5. Thread a new 8mm hub retaining bolt into end of compressor shaft. Tighten hub retaining bolt to 11-13 N·m (8-10 lb-ft). DO NOT USE AIR TOOLS.
6. Check clutch air gap between clutch hub and pulley mating surfaces with a feeler gauge. The air gap should be between 0.45 and 0.85mm (0.018 and 0.033 inch). Check at three locations equally spaced around the pulley.

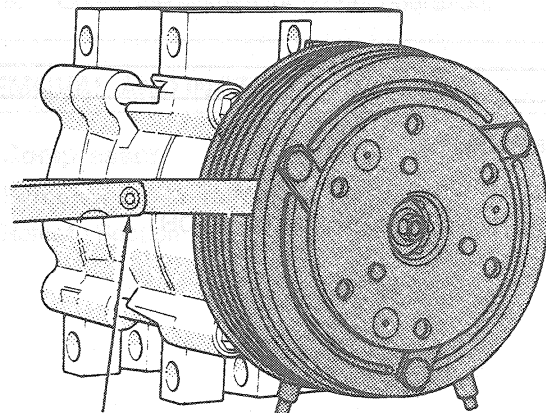

FEELER
GAUGE

CCL 3308-A

7. If clutch air gap is not within 0.45 to 0.85mm (0.018 to 0.033 inch), repeat Steps 4 through 6 with various thickness shims until air gap is within specified limits.

REMOVAL AND INSTALLATION (Continued)

- When installing a new clutch, cycle it ten times at idle to burnish the clutch and prevent slippage.

Clutch Field Coil

NOTE: The clutch field coil is pressed on the front head of the compressor. Special service tools are required to remove and install the coil.

Tools Required:

- Shaft Protector Tool T89P-19623-CH
- Shaft Protector T89P-19623-FH
- 2-Jaw Puller T77F-4220-B1
- Coil Pressing Tool T89P-19623-EH
- 2-Jaw Puller D80L-1002-L

Removal

- Remove the compressor from vehicle. Refer to Section 12-03A.
- Remove the clutch hub and pulley as described in this section.
- Install Shaft Protector Tool T89P-19623-FH on the nose opening of the compressor.
- Install 2-Jaw Puller T77F-4220-B1 on the compressor. Place the tip of the puller forcing screw in the center pilot of the shaft protector and the jaws of the puller around the back edge of the field coil.
- Tighten the puller forcing screw to pull the coil from the compressor head. **DO NOT USE AIR TOOLS.**

REMOVAL AND INSTALLATION (Continued)

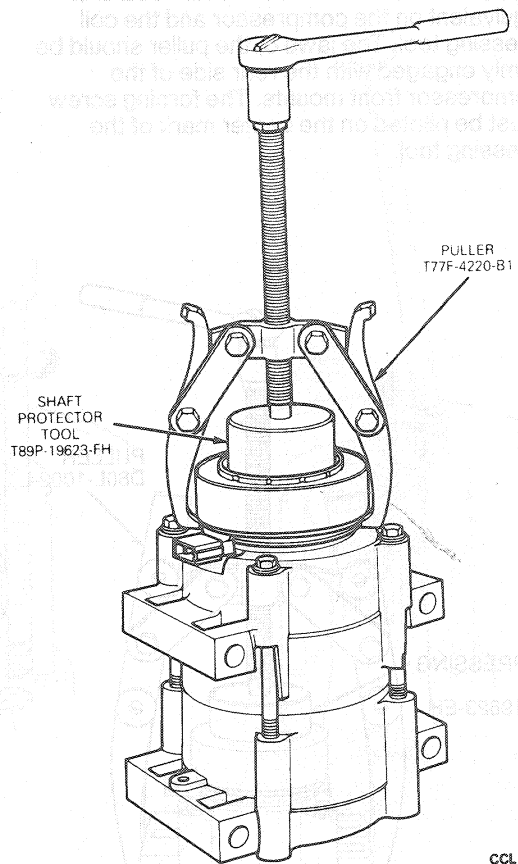

CCL 3422-A

Installation

- Clean the coil mounting surface on the front head to remove any dirt or corrosion.
- With the compressor in a vertical position (nose up), place the field coil in position on the compressor front head. Make sure the coil electrical connector is positioned correctly.
- Place the Coil Pressing (Installer) Tool T89P-19623-EH in position over the compressor nose and to the inner radius of the field coil.

REMOVAL AND INSTALLATION (Continued)

4. Position 2-Jaw Puller Tool D80L-1002-L or equivalent on the compressor and the coil pressing tool. The jaws of the puller should be firmly engaged with the rear side of the compressor front mounts. The forcing screw must be piloted on the center mark of the pressing tool.

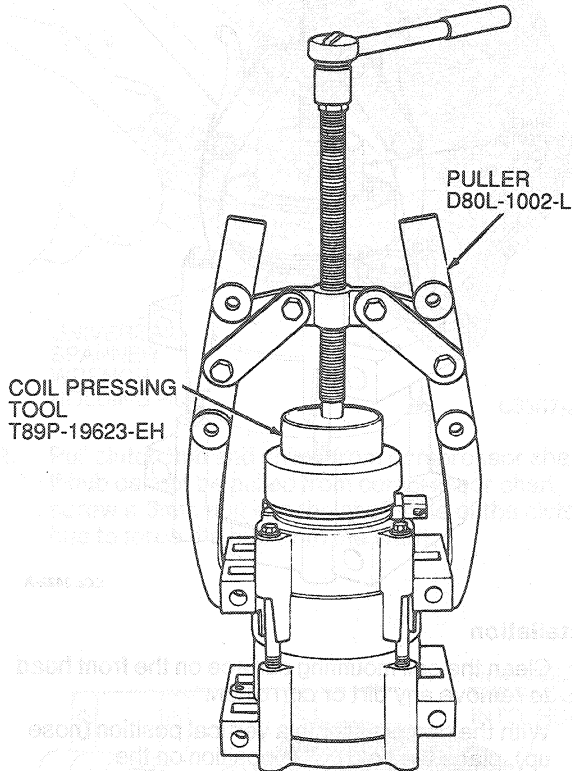

L7716-A

5. Tighten the forcing screw with a hand wrench until the coil is pressed on the compressor front head. **DO NOT USE AIR TOOLS.** Check to make sure that the field coil bottoms against the head at all points around the coil outer diameter.
6. Install the clutch pulley and hub on the compressor as outlined. Adjust the air gap, as necessary.
7. Install the compressor on the vehicle following the recommended procedure.

Shaft Seal

The refrigerant system must be discharged and the compressor must be removed from the vehicle prior to replacing the compressor shaft seal. Refer to Section 12-00.

Tools Required:

- O-Ring Tool T71P-19703-C
- Snap Ring Remover T89P-19623-DH
- Shaft Seal Remover Tool T89P-19623-BH
- Shaft Seal Protector T89P-19623-CH
- Shaft Seal Installer Tool T89P-19623-AH

Removal

1. Remove clutch hub from compressor as outlined.
2. Remove shaft seal felt from nose of compressor with O-ring Remover T71P-19703-C.

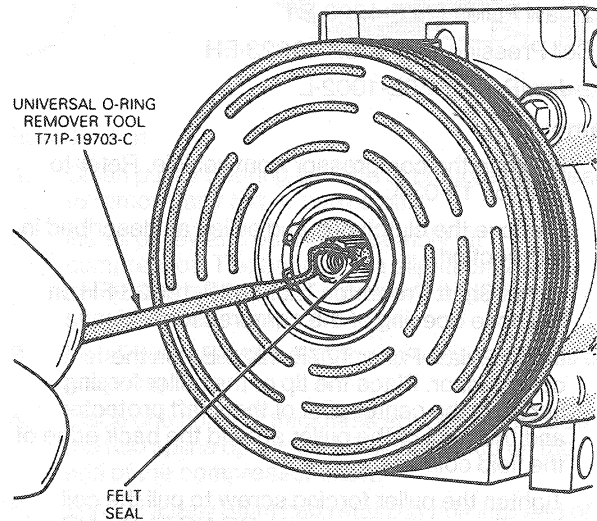

CCL 3309-A

3. Blow any debris from inside the compressor nose with **low pressure** compressed air. Then clean the inside and outside nose area of the compressor with a lint free cloth to remove any oil and dirt.
4. Remove shaft seal retaining snap ring from inside compressor nose with Snap Ring Remover T89P-19623-DH as described in the following steps. Refer to the illustrations.
5. Insert the tip of the Snap Ring Remover T89P-19623-DH into one of the snap ring eyes (View A).
6. Rotate the snap ring remover to position the tool tip and the snap ring eye closest to the compressor shaft (View B).
7. Pull the snap ring remover up quickly while keeping the tool shaft against the side of the nose opening and remove the snap ring (View C).

REMOVAL AND INSTALLATION (Continued)

Snap Ring Removal

TOOL
T89P-19623-DH

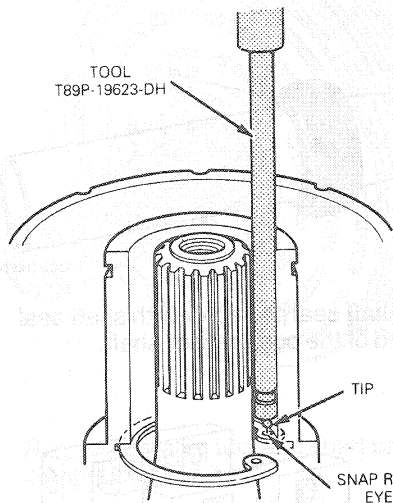

VIEW A

ROTATE

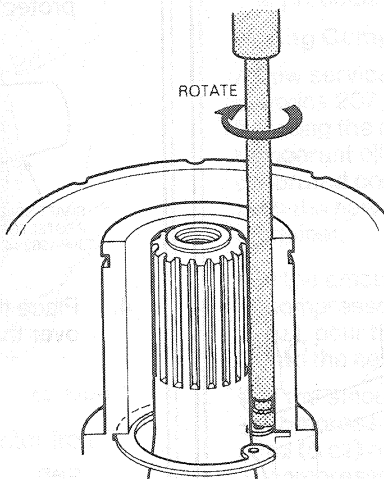

VIEW B

PULL
UPWARD
QUICKLY

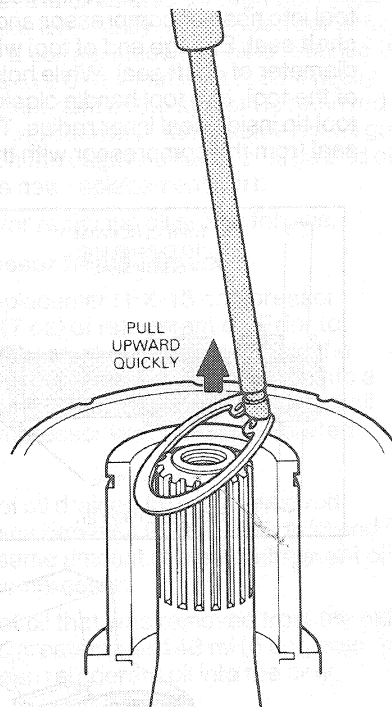

VIEW C

CCL 3412-A

REMOVAL AND INSTALLATION (Continued)

1. Remove the snap ring from the compressor shaft and push the shaft into the compressor housing and allow the shaft to expand. While holding the shaft, use the tool to pull the snap ring out of the housing. Then pull the shaft out of the housing.

CAUTION: Do not use protector if it is damaged. Obtain another shaft seal kit and use protector from it.

REMOVAL AND INSTALLATION (Continued)

8. Position Shaft Seal Remover Tool T89P-19623-BH over compressor shaft and push tool into nose of compressor and down against shaft seal. Engage end of tool with internal diameter of shaft seal. While holding the hex part of the tool, turn tool handle clockwise to expand tool tip inside seal inner radius. Then, pull shaft seal from the compressor with the tool.

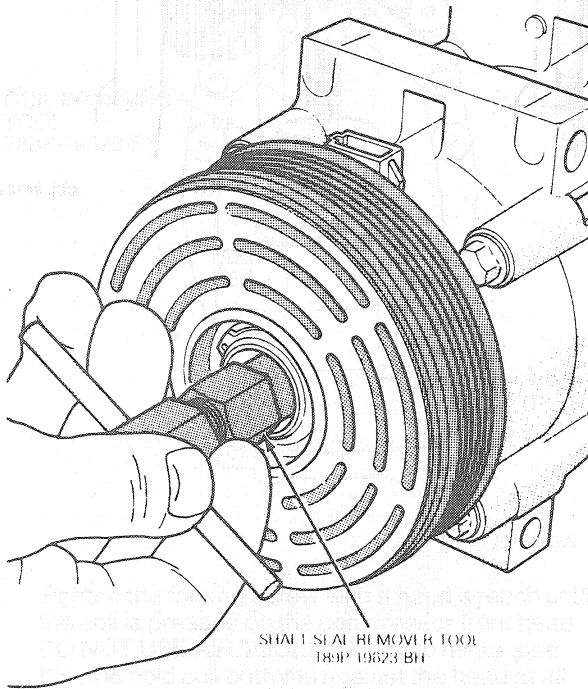
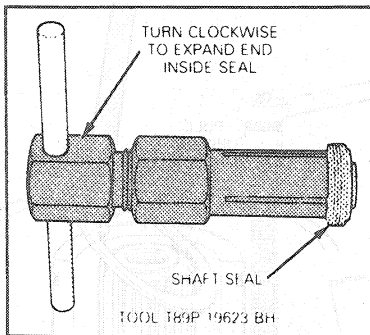

CCL 3310-A

Installation

1. Obtain a new Shaft Seal Kit (Basic Part No. 19D665). Carefully remove the contents of the kit from the package. A plastic shaft seal protector is included with each kit. Inspect the protector for any burrs or other damage. Do not use the protector if it is damaged. Obtain another shaft seal kit, if necessary, and use the protector from it.

CAUTION: Do not use protector if it is damaged. Obtain another shaft seal kit and use protector from it.

2. Using a clean lint free cloth, clean the compressor shaft and the seal pocket inside the compressor nose.

CAUTION: Do not allow any dirt or foreign materials to enter the compressor.

3. Dip the shaft seal protector and shaft seal in clean Refrigerant Oil (E73Z-19577-A). Position the shaft seal on the protector with the lip of the seal pointing toward the large end of the protector.

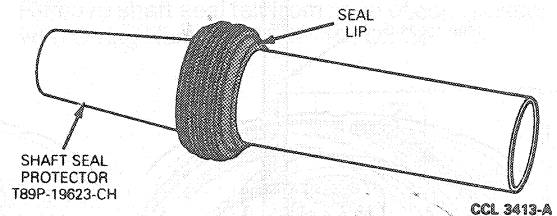

4. Place the shaft seal protector with shaft seal over the end of the compressor shaft.

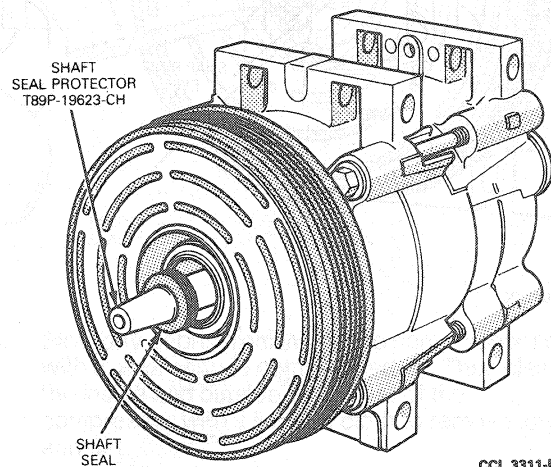

CCL 3311-B

REMOVAL AND INSTALLATION (Continued)

5. Using Shaft Seal Installer Tool T89P-19623-AH, slowly push seal down shaft protector onto compressor shaft until seated.

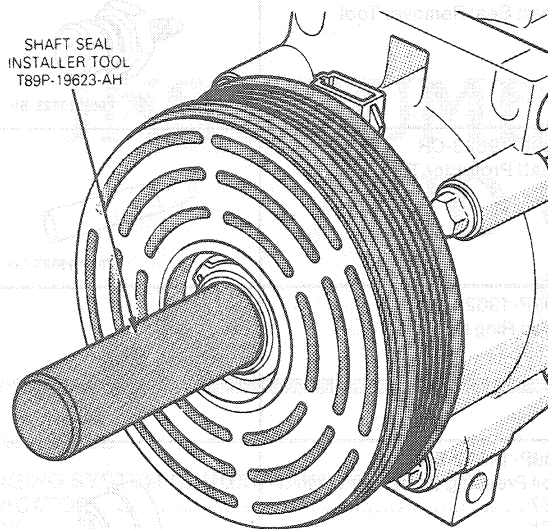

CCL 3312-A

6. Remove installer tool and shaft protector from compressor shaft.
7. Place a new shaft seal retaining snap ring into the compressor nose opening and seat the snap ring into the groove.
8. Leak test the shaft seal installation after rotating the compressor shaft about ten revolutions with the clutch hub. Refer to Compressor External Leak Test.
9. Install a new shaft seal felt in nose of compressor.
10. Install clutch hub on compressor as outlined.
11. Check and adjust the air gap as necessary.

MAINTENANCE

Adding Refrigerant Oil

The FX-15 compressor uses a unique high-quality refrigerant oil (E73Z-19577-A), Motorcraft Part Number YN-9 or an equivalent refrigerant oil meeting Ford specification ESH-M2C3 1-A2. An oil charge of 207 ml (7 oz) is used in a new system. It is extremely important that only the specified type and quantity of refrigerant oil be used in the FX-15 compressor. If there is a surplus of oil in the system, it will circulate with the refrigerant, reducing the cooling capacity of the system. Using too little oil or oil not meeting the Ford specification will result in poor lubrication of the compressor.

When replacing a component of the refrigerant system, the procedures in this section must be followed to ensure that the total oil charge in the system is correct after the new part is installed.

When the compressor is operated, oil gradually leaves the compressor and is circulated through the system with the refrigerant. Eventually, a balanced condition is reached in which a certain amount of oil is retained in the compressor and a certain amount is continually circulated. If a component of the system is removed after the system has been operated, some oil will go with it. To maintain the original total oil charge add oil as required to the new replacement part.

The procedures for replacing oil are as follows:

During Compressor Replacement

A new service replacement FX-15 compressor contains 207 ml (7 oz) of refrigerant oil. Prior to installing the replacement compressor, drain the refrigerant oil from the removed compressor into a calibrated container. Then, drain the refrigerant oil from the new compressor into a clean calibrated container.

- If the amount of oil drained from the removed compressor was between 90 and 148 ml (3 and 5 oz), pour the same amount of clean refrigerant oil into the new compressor.
- If the amount of oil that was removed from the old compressor is greater than 148 ml (5 oz), pour 148 ml (5 oz) of clean refrigerant oil into the new compressor.
- If the amount of refrigerant oil that was removed from the old compressor is less than 90 ml (3 oz), pour 90 ml (3 oz) of clean refrigerant oil into the new compressor.

NOTE: The suction accumulator / drier and orifice tube should also be replaced when the compressor is replaced.

During Component Replacement

When replacing other components of the air conditioning system, measured quantities of the specified refrigerant oil should be added to the component to ensure that the total oil charge in the system is correct before the system is operated.

Clean refrigerant oil should be poured directly into the replacement components as follows:

- Evaporator core: add 90 ml (3 oz).
- Condenser: add 30 ml (1 oz).
- Accumulator: drain oil from removed accumulator / drier. Add same amount plus 60 ml (2 oz) of clean refrigerant oil to new accumulator.

If any other component such as an orifice tube or a hose is replaced, no additional refrigerant oil is necessary unless a hose bursts with a fully charged system. Then, the addition of refrigerant oil may be necessary with the amount to be determined by the technician. The suction accumulator / drier should also be replaced under these circumstances.



SPECIFICATIONS

COMPRESSOR SPECIFICATIONS



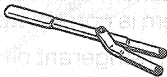

Description	Specification
TYPE	SWASHPLATE, 5 DOUBLE ACTING PISTONS — AXIAL TYPE
DISPLACEMENT	10.4 CID (170cc)
CYLINDER BORE (Dia.)	29.0mm
STROKE	25.7mm
ROTATION	CLOCKWISE
ROTATIONAL TORQUE (Maximum, manifold removed)	10 N·m — (7 Lb·Ft)
REFRIGERANT OIL Ford Specification	ESH-M2C31-A2
Capacity (System Total)	207 ml (7 ounces) 295 ml (10 ounces) with auxiliary A / C
Part Number	E73Z-19577-A Motorcraft YN-9
MAGNETIC CLUTCH Air Gap Between Pulley and Hub	0.45mm-0.85mm (0.018-0.033 Inch)
Current Draw	4.36 Amps @ 12.8 volts
Run-Out (Maximum)	0.02 Inch-Radial or Axial
TORQUE LIMITS Hose & Manifold Assy. to Compressor Bolt	18-23 N·m (13-17 Lb·Ft)
Clutch Hub Bolt	11-13 N·m (8-10 Lb·Ft)

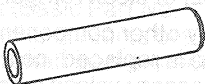
TL8142A

SPECIAL SERVICE TOOLS

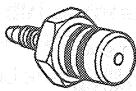
Tool Number / Description	Illustration
T70P-4067-A Spanner Wrench	 T70P-4067-A
T71P-19703-C O-Ring Tool	 T71P-19703-C
T89P-19623-AH Seal Installer Tool	 T89P-19623-AH

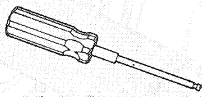
(Continued)

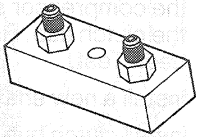
Tool Number / Description	Illustration
T89P-19623-BH Shaft Seal Remover Tool	 T89P-19623-BH
T89P-19623-CH Shaft Protector Tool	 T89P-19623-CH
T89P-19623-DH Snap Ring Remover	 T89P-19623-DH
T89P-19623-EH Coil Pressing (Installer) Tool	 T89P-19623-EH
T89P-19623-FH Shaft Protector Tool	 T89P-19623-FH
T89P-19623-H Pressure Test Fitting Tool	 T89P-19623-H

Tool Number	Description
D80L-1002-L	2-Jaw Puller

ROTUNDA EQUIPMENT

Model	Description
055-00015	Electronic Leak Detector