

DISASSEMBLY AND ASSEMBLY (Continued)

(Continued) DISASSEMBLY AND ASSEMBLY

2. Install lower bearing and column mounting bracket. Tighten screws to 7-11 N·m (5-8 lb-ft).

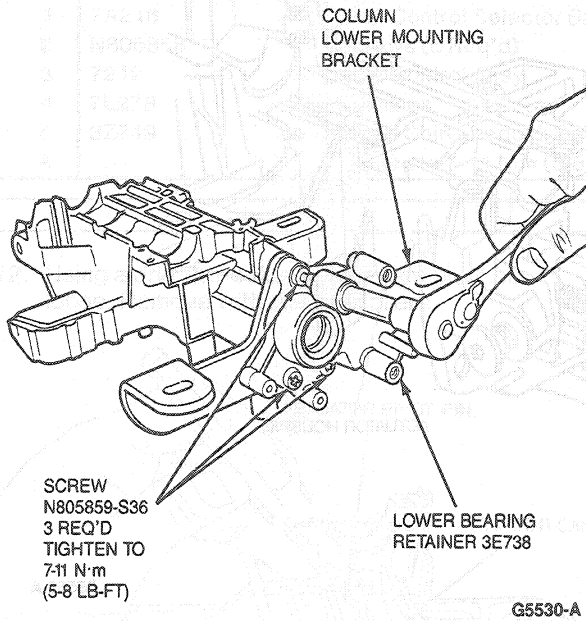

3. Install sensor ring, bushing, spring and flex coupling to steering shaft. Tighten pinch bolt to 41-56 N·m (31-41 lb-ft).

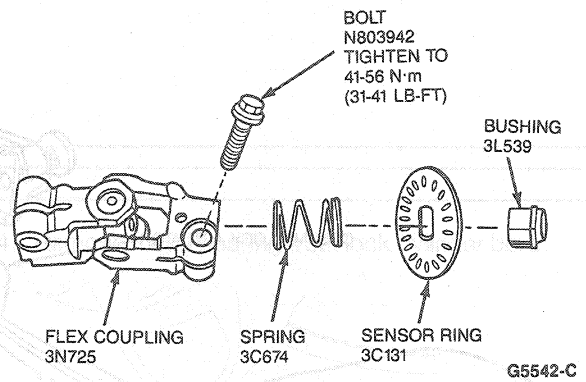

4. Position lock actuator assembly in housing. Spray upper and lower actuators with Multi-Purpose Grease D7AZ-19584-AA (ESR-M1C159-A, ESB-M1C106-B) or equivalent.

