

ADJUSTMENTS (Continued)

2. Install two long bolts and washers through the bushings, and attach to the Bench Mounted Holding Fixture T57L-500-B.

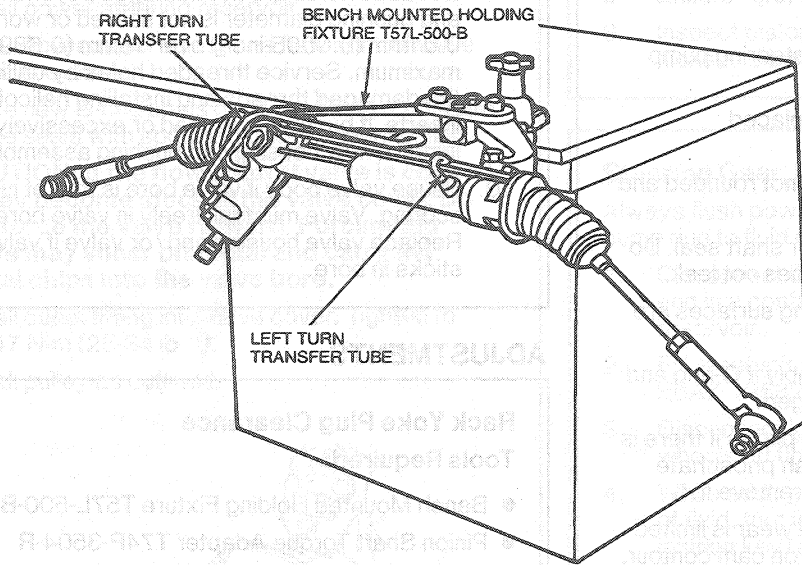

G5784-A

3. Do not remove the external transfer tubes unless they are leaking or damaged. If these lines are removed, they must be replaced with new lines.
4. Drain the power steering fluid by rotating the input shaft lock-to-lock twice using Pinion Shaft Torque Adapter T74P-3504-R. Cover ports on valve housing with shop cloth while draining gear to avoid possible oil spray.
5. Insert a lb-in torque wrench with maximum capacity of 3.39-6.77 N·m (30-60 lb-in) into the Pinion Shaft Torque Adapter T74P-3504-R. Position the adapter and wrench on the input shaft splines.
6. Loosen the yoke plug locknut with Pinion Housing Yoke Locknut Wrench T78P-3504-H.

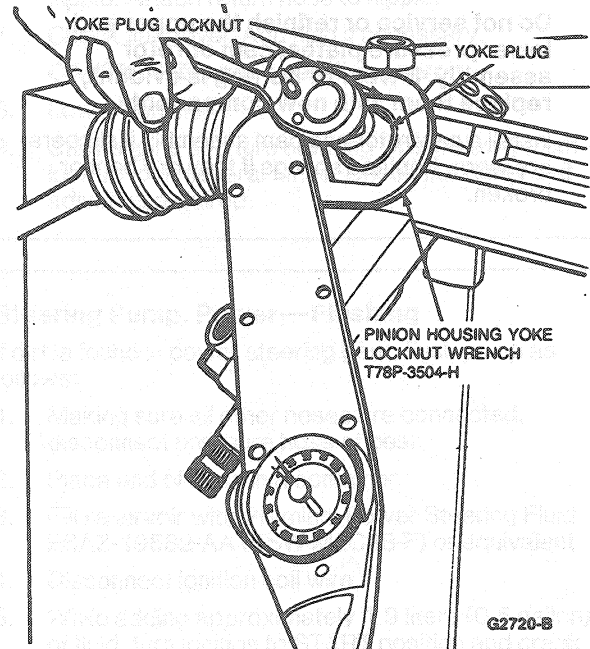

G2720-B

7. Loosen yoke plug with a 3/4-inch socket wrench.