

DISASSEMBLY AND ASSEMBLY (Continued)

10. Lubricate inner and outer O-ring seals with specified power steering fluid, and install these seals on lower pressure plate.

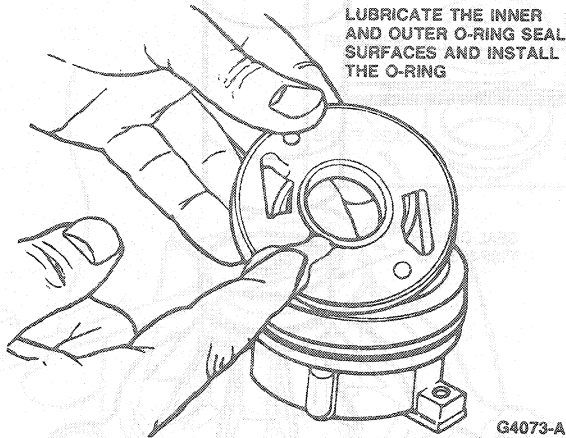

11. Insert lower pressure plate with O-ring seals toward front of pump into housing and over dowel pins.

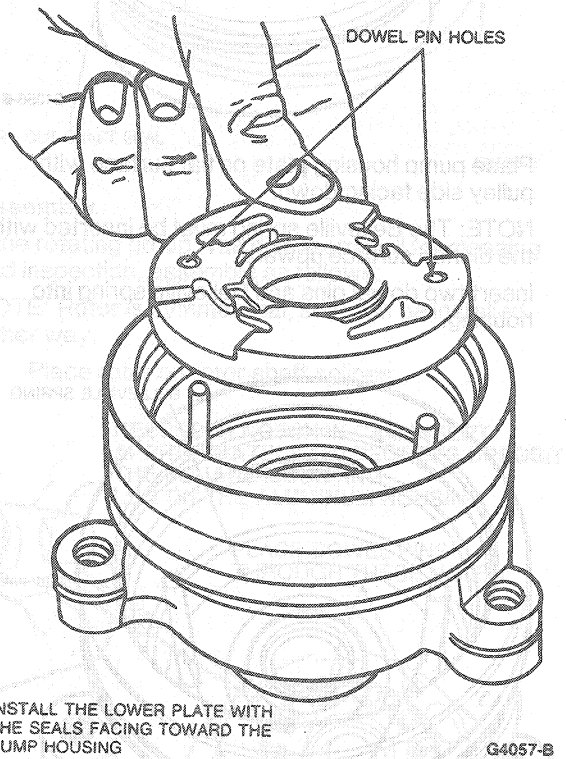

12. Place entire assembly on C-Frame and Clamp Assembly T74P-3044 1-A 1. Place Seal Driver T78P-3733-A3 into rotor shaft hole. Press on lower plate lightly until it is felt to bottom into pump housing. This operation will seat outer O-ring seal.

DISASSEMBLY AND ASSEMBLY (Continued)

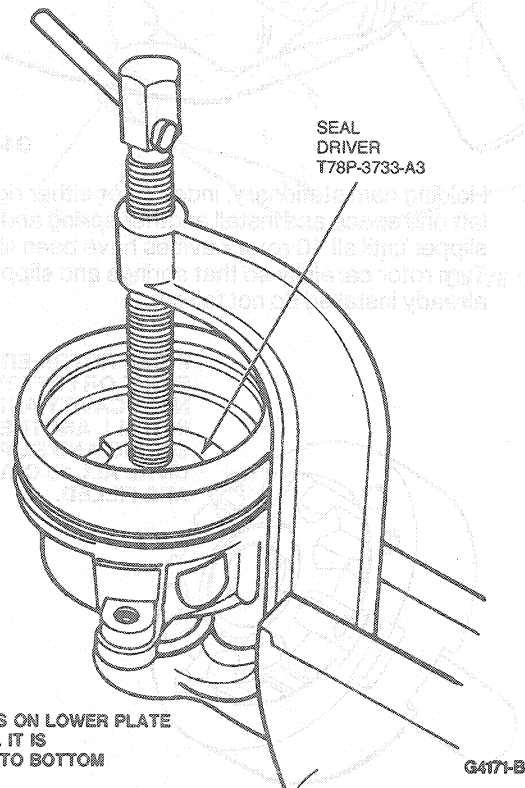
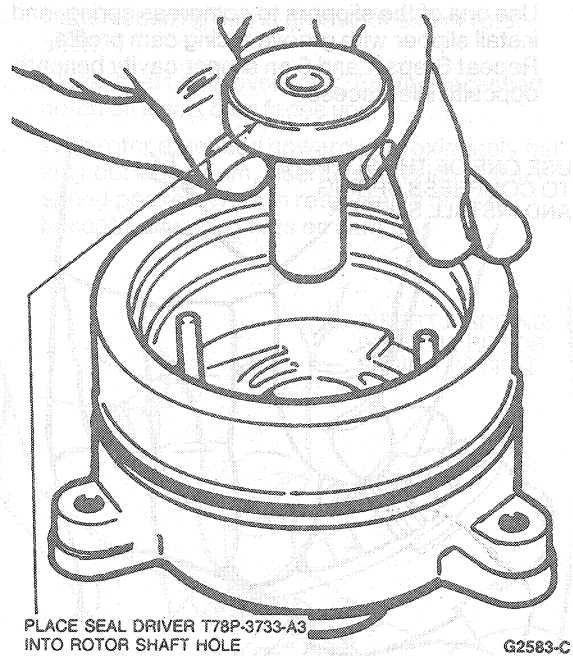

NOTE: When installing this assembly into pump housing, stepped holes must be used for dowel pins, and the recessed notch in cam insert must face toward reservoir and approximately 180 degrees opposite the square mounting lug on aluminum housing. Refer to the illustration under Assembly, Step 1.