

DISASSEMBLY AND ASSEMBLY (Continued)

13. Remove rotor shaft seal and seal retainer simultaneously by prying out with a screwdriver.

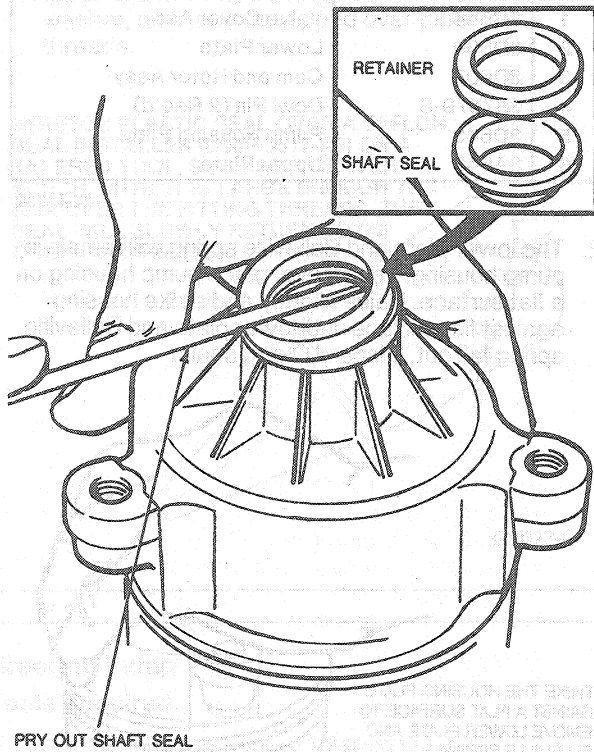

G2578-E

Assembly

If the rotating group was disassembled for cleaning and inspection, assemble as follows:

NOTE: Rotor is symmetrical, so it can be installed either way.

1. Place rotor on rotor shaft splines.

RECESSED NOTCH IN CAM INSERT APPROXIMATELY 180 DEGREES OPPOSITE THE SQUARE MOUNTING LUG ON THE ALUMINUM HOUSING

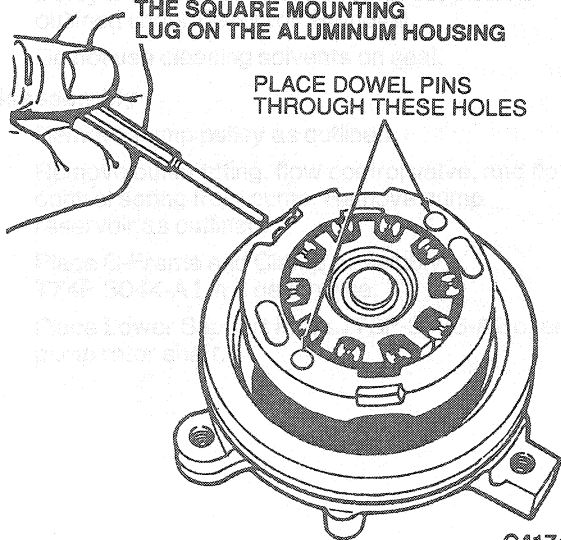

G4174-C

2. Install retaining ring in groove at end of rotor shaft.
3. Place insert cam over rotor. Ensure recessed notch on insert cam faces up.
4. With rotor extended upward approximately half way out of the cam, insert a spring into a rotor spring pocket. Work in rotor cavity directly beneath recessed flats on cam.

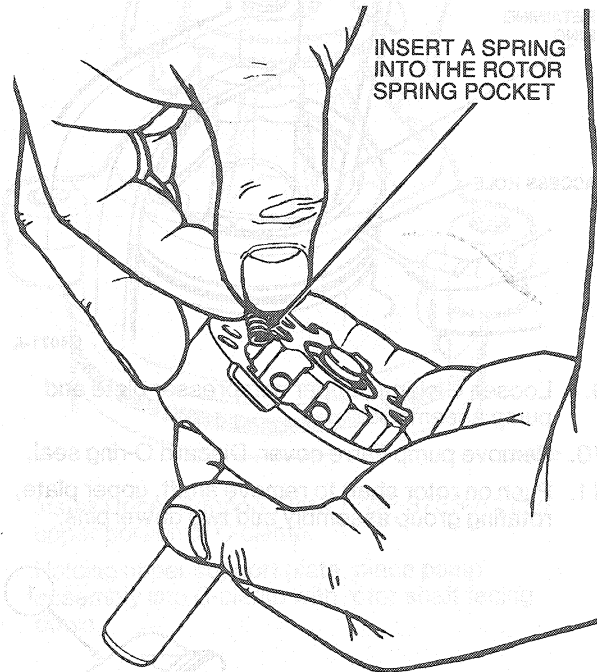

G4175-C