

DISASSEMBLY AND ASSEMBLY (Continued)

12. Install rack, taking care NOT to scratch housing piston bore.
13. Carefully push piston through sizing tool. Continue pushing on rack until it bottoms. Remove sizing tool.

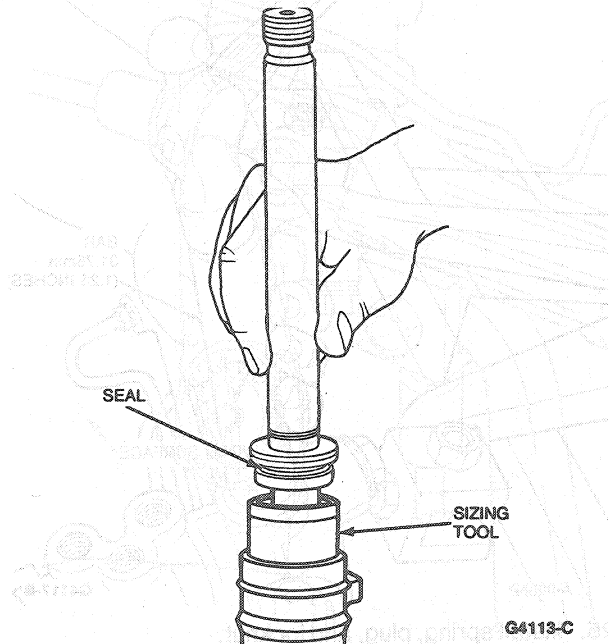

14. Seat rack seal with rack by driving end of rack with a drift or brass bar stock and plastic mallet. Several hits may be required to ensure proper seating. **DO NOT** remove rack.

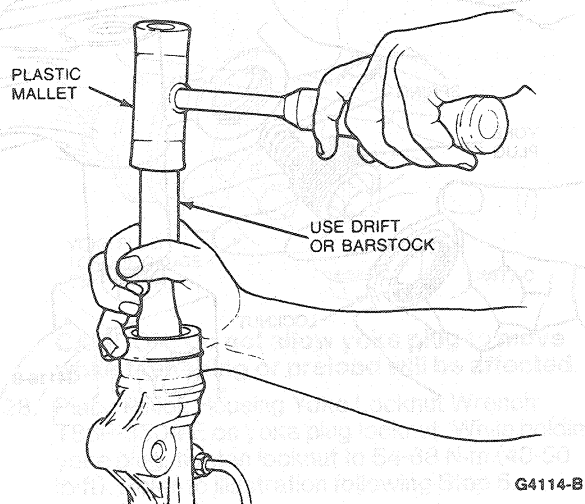

15. Move rack so it is centered in housing.
16. Thread Rack Seal Protector Sleeve T74P-3504-J over threads on RH side of rack. Apply power steering fluid to protective sleeve.

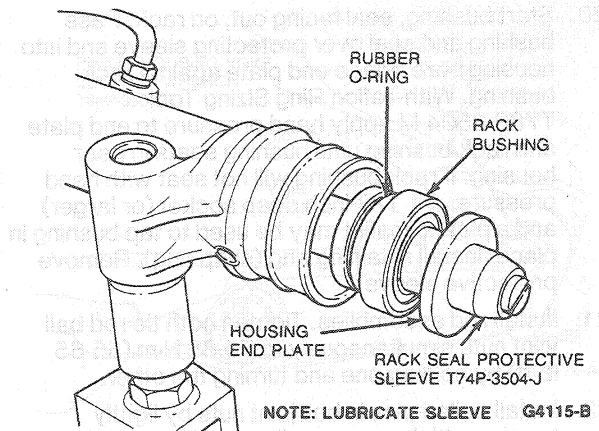

17. Install rubber O-ring on aluminum rack bushing.
18. Apply Steering Gear Grease C3AZ-19578-A (ESW-M1C87-A) or equivalent to the outer rack oil seal. With Outer Rack Seal Replacer T74P-3504-F, install high-pressure oil seal in rack bushing. Lip spring must face the inside of the bushing.

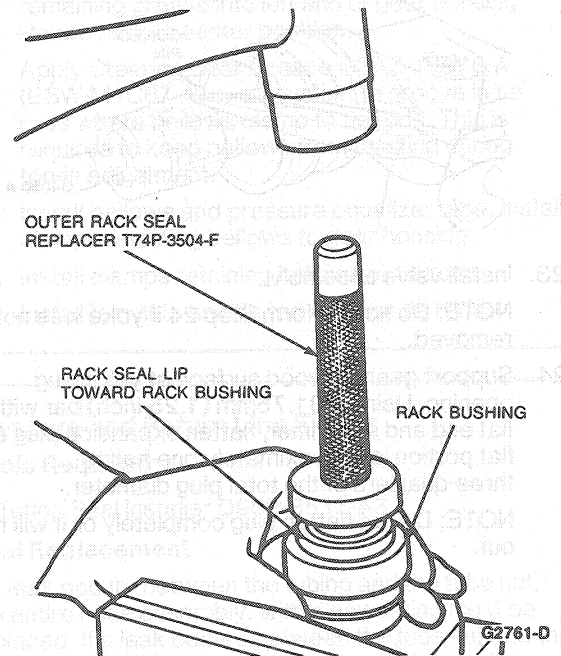

19. Lubricate short Rack Seal Protective Sleeve T74P-3504-J on rack end and rubber O-rings on rack bushing with Steering Gear Grease C3AZ-19578-A (ESW-M1C87-A) or equivalent. Refer to illustration under Step 16.