

DISASSEMBLY AND ASSEMBLY (Continued)

Assembly

1. If yoke was removed during disassembly, a new yoke is required. Coat new yoke with Steering Gear Grease C3AZ-19578-A (ESW-M1C87-A) or equivalent and install through expansion plug opening, rack bearing surface up.

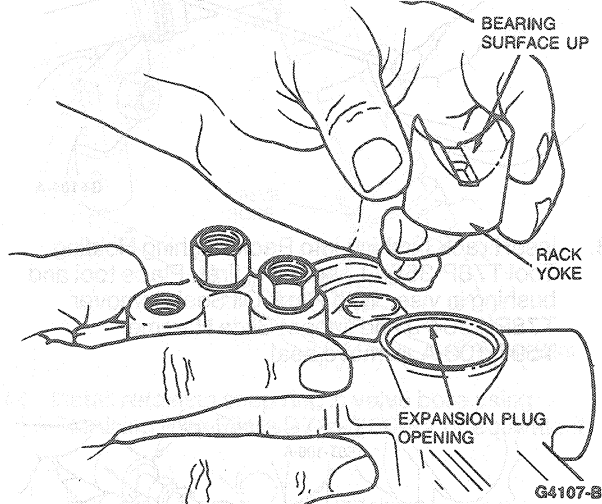

2. Slide Teflon Ring Replacer T74P-3504-G over plain end (without teeth) of rack up to piston. Roll rubber O-ring into piston groove, then slide plastic piston ring into piston groove over O-ring.

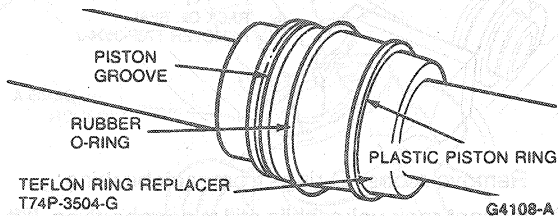

NOTE: Insert is integral part of seal. It is removed only to avoid damage during installation.

3. Remove plastic insert from rack seal. Save insert for installation.

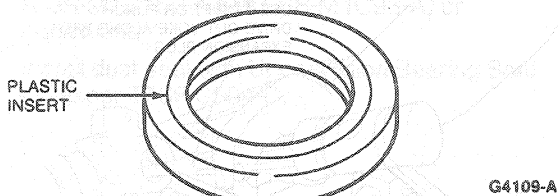

4. Install Rack Seal Protector T85L-3504-B over rack teeth.
5. Lubricate rack seal protector and rack with power steering fluid.
6. Install seal with lip toward piston. Push seal all the way against piston. Remove rack seal protector.

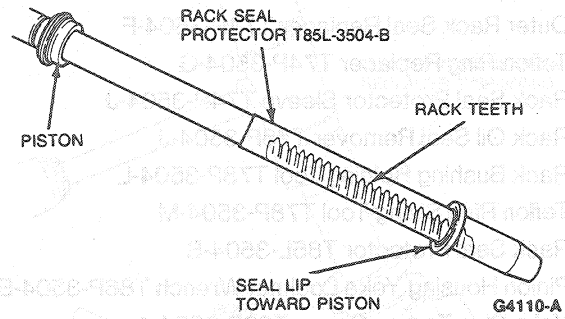

7. Install plastic insert in rack seal.

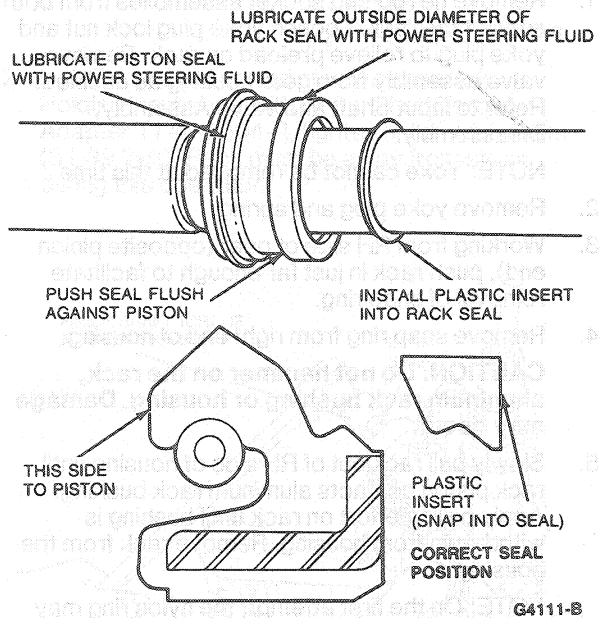

8. Pack rack teeth with Steering Gear Grease C3AZ-19578-A (ESW-M1C87-A) or equivalent. Apply a light coat of steering gear lubricant to yoke contact area on back of rack teeth.

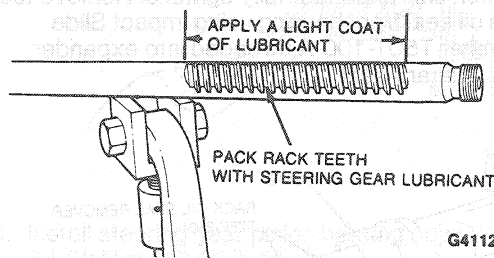

9. Lubricate piston seal and rack seal outside diameter with power steering fluid. Refer to the illustration under Step 7.
10. Install Teflon Ring Sizing Tool T78P-3504-M into end of gear housing.
11. Ensure yoke is all the way in when installing rack.