

DISASSEMBLY AND ASSEMBLY (Continued)

Install third valve sleeve ring by pushing on it rapidly with Pusher T75L-3517-A2. The ring will snap into proper groove.

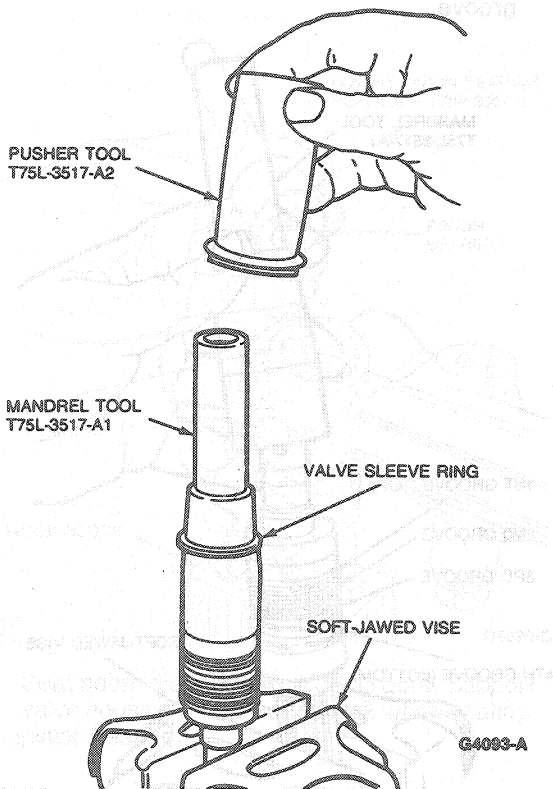

8. Repeat Step 7 using one spacer for second valve sleeve ring (Spacer T75L-3517-A3).

NOTE: USE NO SPACERS FOR 3RD GROOVE, ONE SPACER FOR 2ND GROOVE AND TWO SPACERS FOR 1ST GROOVE (TOP)

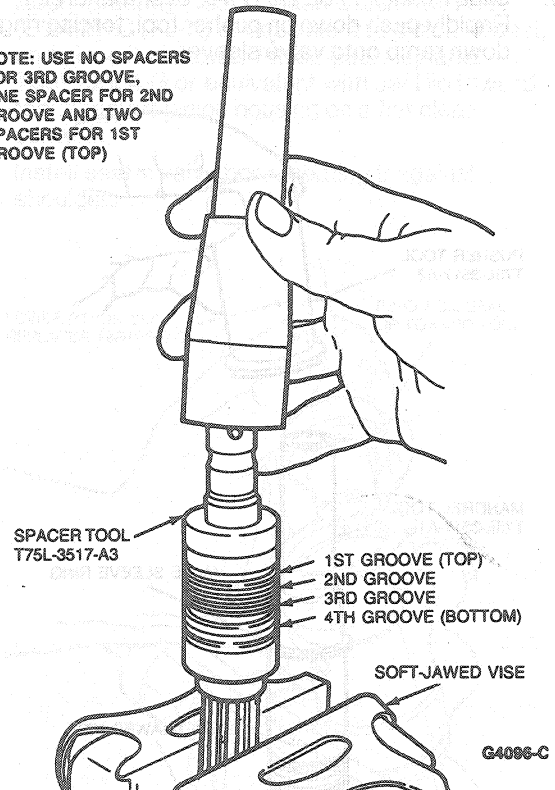

9. Repeat Step 7 using two spacers for the first (top) valve sleeve ring (Spacer T75L-3517-A3).
10. After installing four valve sleeve rings, apply a light coat of Steering Grease C3AZ-19578-A (ESW-M1C87-A) or equivalent to sleeve and rings.
11. Slowly install Sizing Tube T75L-3517-A4 over sleeve valve end of input shaft onto valve sleeve rings. Ensure that rings are not being bent over as tube is slid over them.

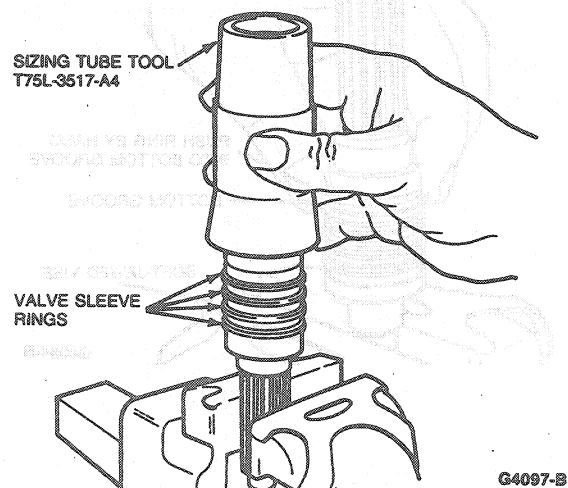

Remove sizing tube, and check condition of rings. Ensure that rings turn freely in grooves.