

DISASSEMBLY AND ASSEMBLY (Continued)

- Slide Pusher T75L-3517-A2 over mandrel. Rapidly push down on pusher tool, forcing ring down ramp onto valve sleeve.

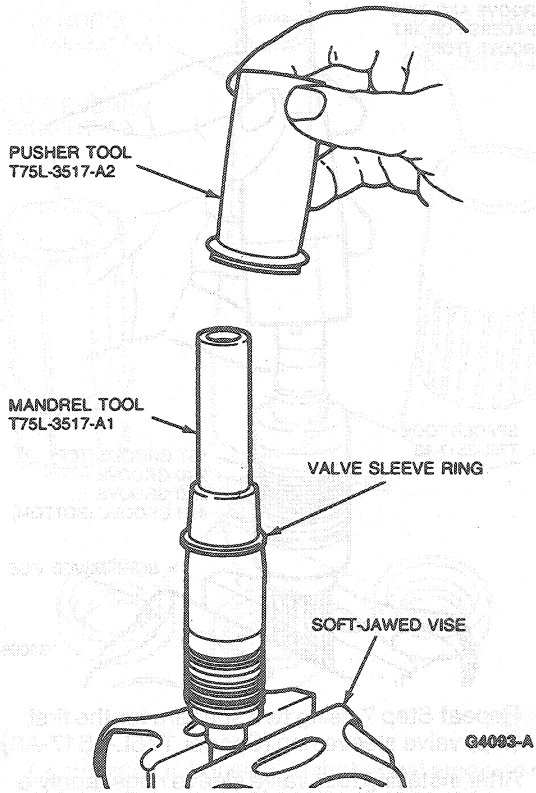

Complete installation by pushing ring into bottom groove.

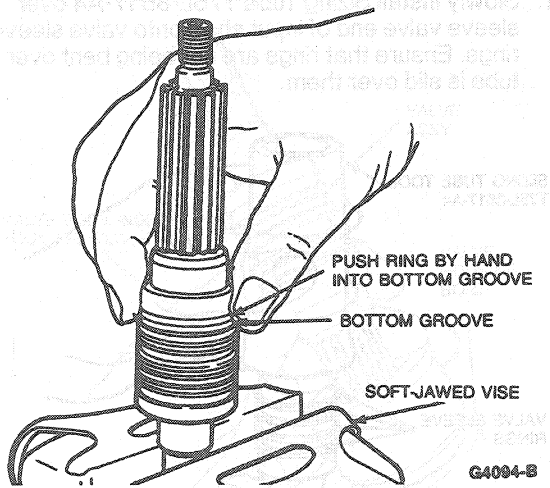

- Remove valve assembly from vise and regrip it with pinion gear teeth.
- Install Mandrel T75L-3517-A1 over input shaft. Mandrel will align with the third (next to bottom) groove.

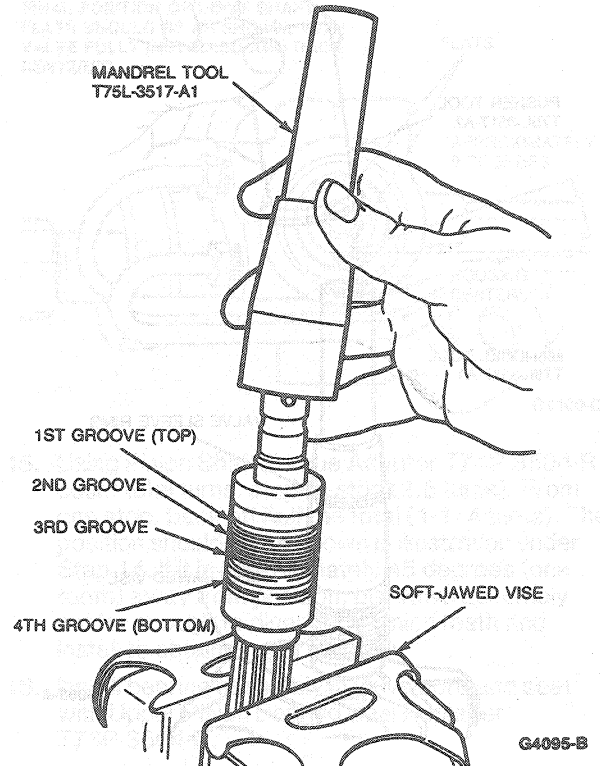

NOTE: Seal grooves do not have port holes. Ensure seals are installed in proper grooves.