

DISASSEMBLY AND ASSEMBLY

Tie Rods, Bellows

Tools Required:

- Bench Mounted Holding Fixture T57L-500-B
- Nut Wrench T74P-3504-U
- Locknut Pin Remover D81P-3504-N

Disassembly

1. Mount gear assembly in Bench Mounted Holding Fixture T57L-500-B.

NOTE: Drill out mounting holes in holding fixture with a 9/16-inch drill to allow the gear assembly mounting bolts to fit.

2. Remove tie rod ends.
3. Remove four clamps retaining bellows to gear housing and tie rods. Discard clamps if damaged or excessively corroded.

CAUTION: Use care not to damage bellows.

4. Remove bellows along with breather tube.
NOTE: For units equipped with rivets in place of the coiled pins, perform Steps 6 and 7.
5. Using Locknut Pin Remover D81P-3504-N or equivalent, remove coiled lock pins from inner tie rod ball joints.

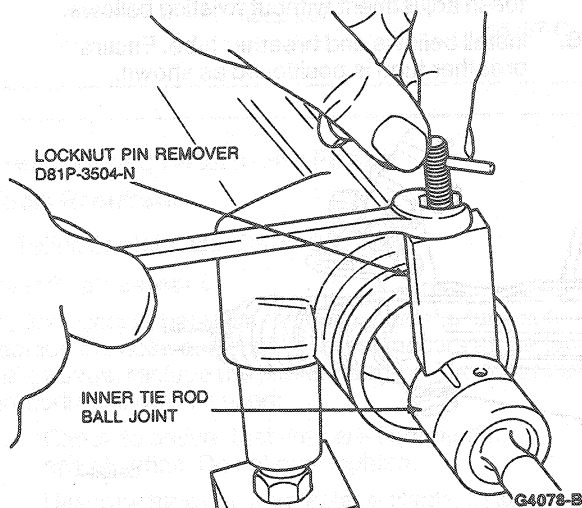

6. With a sharp chisel, gently tap around rivet head so it lifts away from ball joint. Use caution so the center pin is not sheared off.

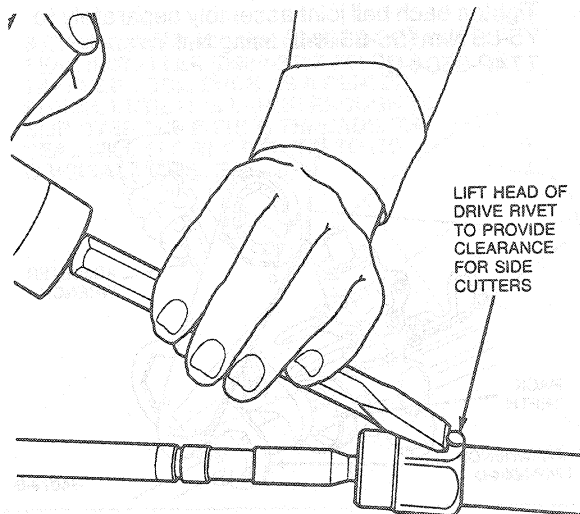

7. Use side cutters to pry out drive pin.
8. Position rack so that several rack teeth are exposed. Hold rack with an adjustable wrench on end teeth only, while loosening ball joint nuts with Nut Wrench T74P-3504-U.

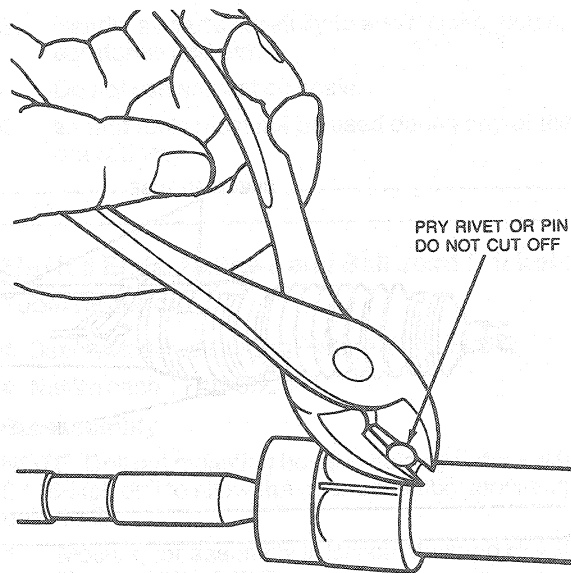

Assembly

1. Expose several rack teeth and hold rack with adjustable wrench.