

**DIAGNOSIS AND TESTING (Continued)**

The procedure is a systematic method of determining which of the above components, if any, require servicing. Testing can be done using Rotunda Digital Volt Ohmmeter 007-00001, Rotunda Inductive Dwell-Tach-Volt-Ohm Tester 059-00010 or equivalent.

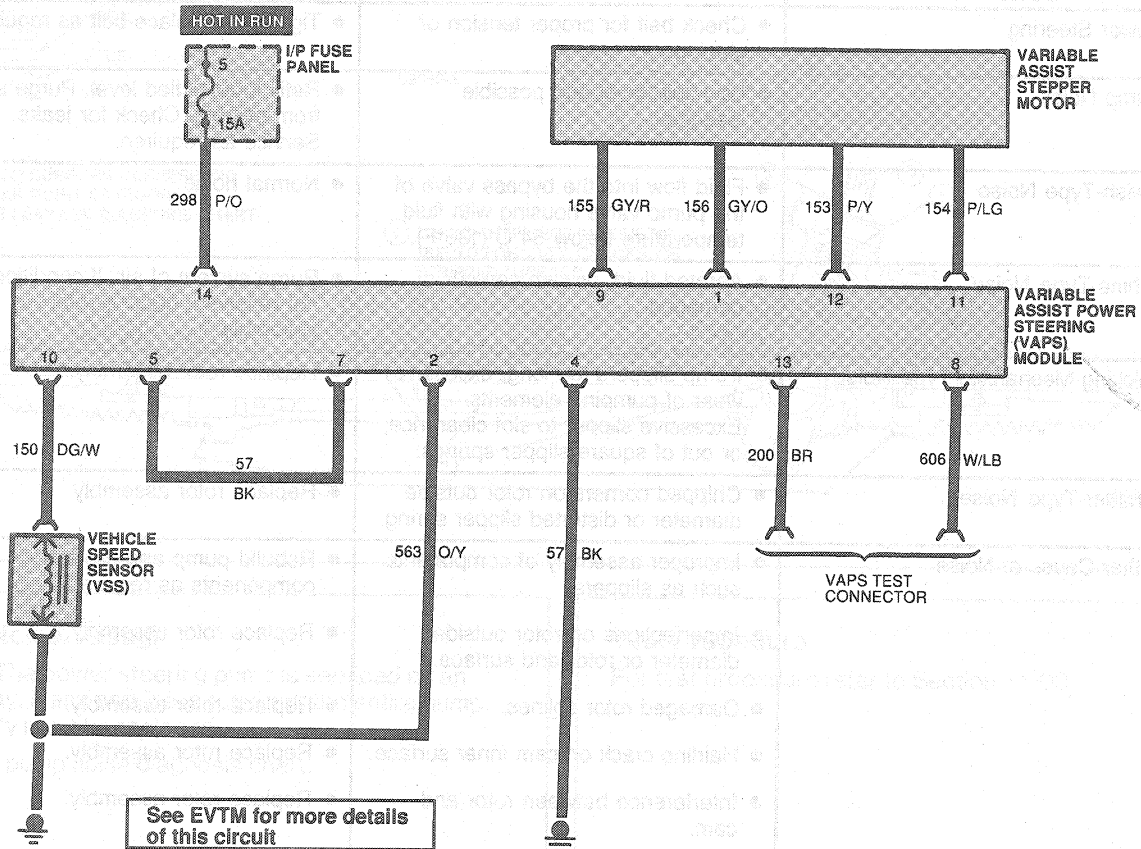

G7176-A

**VAPS Connector End View**

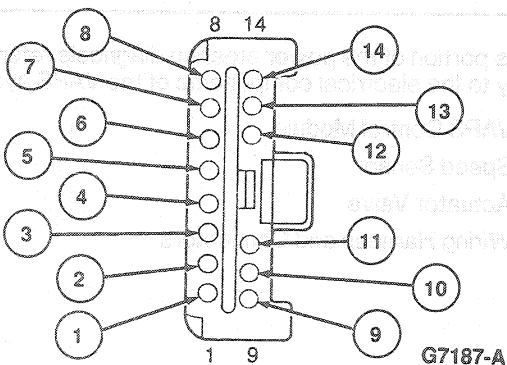

G7187-A

Item	Part Number	Description
1	156 (GY / O)	Stepper Motor
2	563 (O / Y)	Ground
3	—	Not Used
4	57 (BK)	Ground
5	57 (BK)	Ground
6	—	Not Used
7	57 (BK)	Ground
8	606 (W / LB)	VAPS Test Connector 9E731
9	155 (GY / R)	Stepper Motor
10	150 (DG / W)	Vehicle Speed Sensor (VSS)
11	154 (P / LG)	Stepper Motor
12	153 (P / Y)	Stepper Motor
13	200 (BR)	VAPS Test Connector
14	298 (P / O)	Hot in RUN