

DESCRIPTION (Continued)

(Continued)

VAPS Exploded View

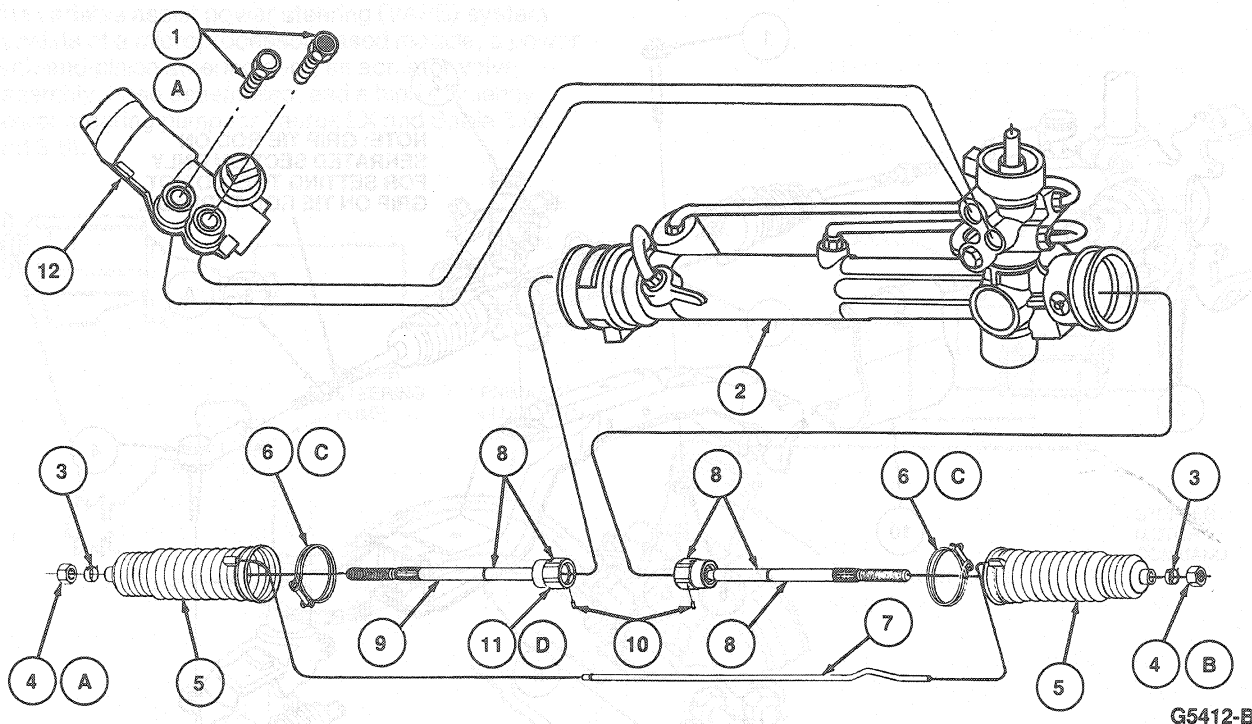

G5412-B

Item	Part Number	Description
1A	3R659	Bolt
2	3548	Steering Gear Housing Assy
3	3C650	Clamp
4B	N803637-S	Nut
5	3332	Boot
6C	N803259-S	Clamp
7	3K762	Breather Tube
8	3280	Tie Rod Assy
9	—	Spindle Rod (Part of 3280)
10	—	Roll Pin (Part of 3280)

(Continued)

Item	Part Number	Description
11D	—	Ball Joint Housing (Part of 3280)
12	3N803	Actuator Assy
A		Tighten to 27-34 N·m (20-25 Lb-Ft)
B		Tighten to 47-68 N·m (35-50 Lb-Ft)
C		Tighten to 2.2-3.4 N·m (20-30 Lb-In)
D		Tighten to 75-88 N·m (55-65 Lb-Ft)

TG5412B

Steering Pump, CII

The Ford Model CII power steering pump is a belt-driven, 10-slipper type pump with a fiberglass-filled nylon reservoir. The reservoir is attached to the rear side of the aluminum pump housing, and the pump body is encased within the housing and reservoir. The pump design incorporates a pump pressure fitting which allows the pump pressure line to swivel. This is normal and does not indicate a loose fitting.