

SECTION 11-05 Steering Column Switches

SUBJECT	PAGE	SUBJECT	PAGE
DESCRIPTION AND OPERATION		DIAGNOSIS AND TESTING	
Cornering Lamp Switching	11-05-2	Continuity Test	11-05-3
Hazard Flasher Switching	11-05-2	Mechanical Test	11-05-3
Headlamp Dimmer / Flash-to-Pass Switching	11-05-2	Switch Continuity	11-05-4
Switch, Blade-Type	11-05-1	Switch, Multi-Function	11-05-3
Switch, Ignition	11-05-1	REMOVAL AND INSTALLATION	
Switch, Multi-Function	11-05-2	Flasher Unit	11-05-7
Turn Signal Switching	11-05-2	Switch, Ignition	11-05-6
Windshield Washer Switching	11-05-2	Switch, Multi-Function	11-05-6
Windshield Wiper Switching	11-05-2	SPECIAL SERVICE TOOLS	11-05-8
		SPECIFICATIONS	11-05-8
		VEHICLE APPLICATION	11-05-1

VEHICLE APPLICATION

Taurus / Sable.

DESCRIPTION AND OPERATION

Switch, Ignition

The ignition switch is mounted on the lock cylinder housing and is controlled by the lock cylinder through a pin which is part of the ignition switch.

The lock cylinder also controls the mechanism which provides a positive lock for the transaxle linkage and the steering system. The locking mechanism is located in the lock cylinder housing at the upper end of the steering column.

The lock cylinder positions are ACC, LOCK, OFF, RUN and START. With column shift automatic transaxle, the lock cylinder key can be removed from the lock cylinder only when the shift lever is in PARK position and the key is in LOCK position. The ACC position operates while the steering and transaxle systems remain locked. Turning the key to OFF position shuts off the engine without locking the steering or transaxle systems.

Switch, Blade-Type

The switch has blade-type terminals that engage with one multiple connector. The multiple connector is secured to the switch by an integral connector fastener.

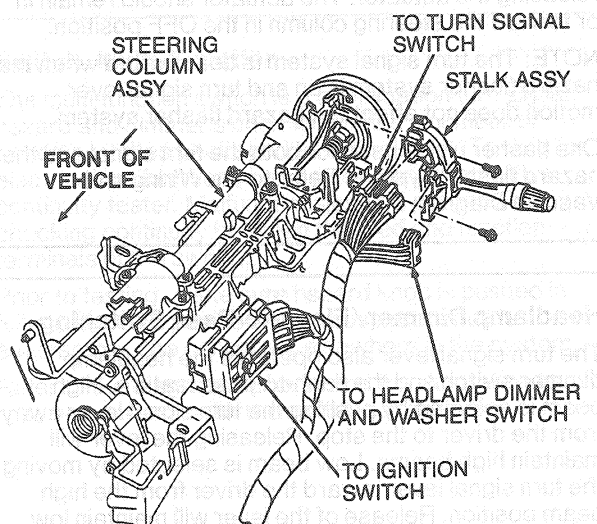

K16531-A

DESCRIPTION AND OPERATION (Continued)**Switch, Multi-Function**

The multi-function switch unifies the turn signal, headlamp dimmer, headlamp flash-to-pass, hazard warning, cornering lamps (optional) and windshield washer / wiper. The multi-function switch assembly is mounted to the steering column.

Turn Signal Switching

The turn signal lever is located on the LH side of the upper steering column. To operate the turn signal(s), the key lock cylinder must be in the RUN position. To indicate a normal full turn, move the turn signal lever to the end-of-travel position for the turn desired. The lever will remain in position without effort until the turn is completed, at which time the steering wheel cancel cam will automatically cancel the turn signal.

The turn signal system also has a lane change feature. To operate the lane change feature, move and hold the turn signal lever to the first stop position when changing lanes. When the lane maneuver is completed, release the lever and it will return to its normal position.

Hazard Flasher Switching

The hazard flasher system operates independently from the key lock cylinder. All turn signal lamps can be made to flash in unison by depressing and releasing the hazard actuator located on the top part of the steering column. The switch is identified by a "double triangle" symbol.

The actuator will move out or away from the steering column to the ON position. The hazard flasher system is turned off by first pushing in the actuator and then releasing the actuator. The actuator should remain in or toward the steering column in the OFF position.

NOTE: The turn signal system is deactivated when the hazard flasher system is on and turn signal lever motion does not affect the hazard flasher system.

One flasher unit is used for both the turn signal and the hazard flasher system. Refer to the Wiring and Vacuum Diagram manual.

Headlamp Dimmer / Flash-to-Pass Switching

The turn signal lever also operates the headlamp dimmer switch and the flash-to-pass feature. High beam is selected by pushing the turn signal lever away from the driver to the stop. Releasing the lever will maintain high beams. Low beam is selected by moving the turn signal lever toward the driver from the high beam position. Release of the lever will maintain low beams.

To operate the flash-to-pass feature, pull the lever gently toward the driver. When the lever is released, it will return to the LO beam position. If driving without headlamps on, use of the flash-to-pass feature will turn on the high beams until the turn signal lever is released. If the headlamps are turned on, the low and high beams will be on until the turn signal lever is released.

NOTE: Excessive force used to hold the turn signal lever in the flash-to-pass function followed by quick release may result in incorrect headlamp dimmer selection of high beam. The driver must be cautioned to avoid this condition.

Cornering Lamp Switching

The cornering lamp switch is coordinated with the turn signal function. In order to operate the cornering lamp function, the headlamps must be turned on.

Windshield Washer Switching

The washer switch is located at the end of the turn signal lever. To operate the washer, the key lock cylinder must be in the RUN position. To actuate the washer, push the end of the turn signal lever in toward the steering column. Releasing the turn signal lever will then turn off the washer. The wiper blades will continue to operate for a few wipes and then automatically return to the wiper speed setting (OFF, LO, HI, or INT) previously selected. Washer operation is available in all positions of wiper operation.

Windshield Wiper Switching**Interval**

The wiper switch is located in the knob at the end of the turn signal lever. To operate the wiper, the key lock cylinder must be in the RUN position. In addition to OFF, there are two fixed speed wiper positions LO (low) HI (high) and an interval position. The positions are selected by rotating the knob actuator relative to the turn signal lever. If interval position is selected, the time between wiper cycles will decrease as the knob is rotated away from OFF position and will increase as the knob is rotated toward OFF position. The time interval between wipes will vary depending on the knob's position from OFF position. The wiper speed for interval wiper operation is fixed at the LO speed setting.

DIAGNOSIS AND TESTING

Continuity Test

Disconnect the multiple connector from the ignition switch. Test the switch continuity as described in the following illustration. Connect a self-powered test lamp or ohmmeter between the blade terminals indicated on the chart. No continuity between any blade and chassis ground should exist in any switch position except the proof Circuits, 41 and 977 in the START position only.

For an "engine won't crank" condition, determine if the condition exists with the shift lever in both PARK and NEUTRAL positions before performing the ignition switch continuity test. If the "no-crank" condition occurs in one shift lever position but not the other, a more probable cause is the neutral start switch located on the transaxle.

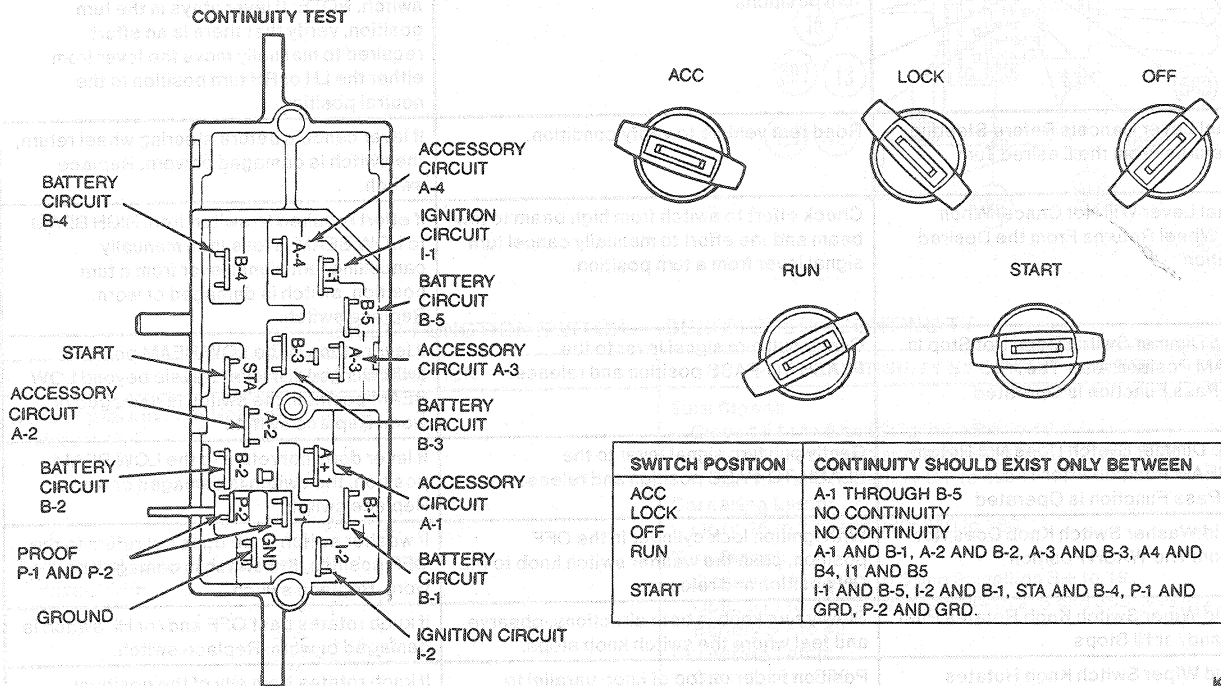

Mechanical Test

Test the steering column ignition system mechanical operation by rotating the lock cylinder / key through all switch positions. The movement should feel smooth with no sticking or binding. The ignition system should return from the START position back to the RUN position without assistance (spring return). If sticking or binding is encountered, check for the following:

- Burrs on the lock cylinder key
 - Binding lock cylinder
 - Shroud rubbing against lock cylinder
 - Burrs or foreign material around rack-and-pinion actuator in lock cylinder housing
 - Insufficient lube on actuator
- NOTE: Do not apply lubricant to the inside of the ignition switch.
- Binding ignition switch

Switch, Multi-Function

The multi-function switch is a combination turn signal, hazard and dimmer switch which has a number of on / off switches packaged as a single unit. Testing for electrical malfunctions can be accomplished with a continuity tester. Malfunctions can be determined by checking continuity between the feed and function terminals of the switch.

Prior to testing, make sure hazard knob is pushed in fully to the OFF position. If the suspect circuit is satisfactory, the concern is elsewhere in the system.

Refer to the diagnostic charts and the illustration to resolve concerns with the multi-function switch.

DIAGNOSIS AND TESTING (Continued)

MECHANICAL MULTI-FUNCTION SWITCH DIAGNOSIS

CONDITION	TEST STEP	ACTION
Hazard Warning Switch Will Not Turn On Warning Lamps	With hazard warning switch in the OFF position, fully depress knob and release.	If knob does not pop up to the ON position, the switch is damaged or worn. Replace switch.
Hazard Warning Switch Will Not Turn Off Warning Lamps	With hazard warning switch in the ON position, fully depress knob and release.	If knob does not pop up to the OFF position, the switch is damaged or worn. Replace switch.
Turn Signal Lever Will Not Stay In The LH/ RH Turn Positions	With steering wheel locked in the straight ahead position, move lever to the RH and LH turn positions.	If lever does not stay in either turn position, the switch is damaged or worn. Replace switch. NOTE: If lever stays in the turn position, verify that there is an effort required to manually move the lever from either the LH or RH turn position to the neutral position.
Turn Signal Lever Cancels Before Steering Wheel Returns From the Desired Turn Position	Road test vehicle to verify condition.	If lever cancels before steering wheel return, the switch is damaged or worn. Replace switch.
Turn Signal Lever Will Not Cancel When Steering Wheel Returns From the Desired Turn Position	Check effort to switch from high beam to low beam and the effort to manually cancel turn signal lever from a turn position.	If effort required to switch from HIGH BEAM to LOW BEAM is less than manually cancelling turn signal lever from a turn position, switch is damaged or worn. Replace switch.
Headlamp Dimmer Switch Does Not Stop In LOW BEAM Position After The Flash-to-Pass Function is Operated	Gently pull turn signal lever to the FLASH-TO-PASS position and release.	If lever stops in the LOW BEAM position, switch is good. If lever travels beyond LOW BEAM position, the switch is damaged or worn. Replace switch.
Headlamp Dimmer Switch Does Not Return to LOW BEAM Position After The Flash-to-Pass Function Is Operated	Gently pull turn signal lever to the FLASH-TO-PASS position and release.	If lever does not return to the LOW BEAM position, the switch is damaged or worn. Replace switch.
Windshield Washer Switch Knob Does Not Return From The WASH Position	With ignition lock cylinder in the OFF position, push the washer switch knob to the ON position and release.	If washer switch knob does not return to the OFF position, the switch is damaged or worn. Replace switch.
Windshield Wiper Switch Knob Rotates Past The OFF and/or HI Stops	Slowly turn knob in both directions, observe and feel where the switch knob stops.	If knob rotates past OFF and/or HI, switch is damaged or worn. Replace switch.
Windshield Wiper Switch Knob Rotates Easily From OFF, LO HI or the INTERVAL Position During Turn Signal or Headlamp Dimmer Operation	Position finger on top of knob parallel to steering column. Gently pull finger back toward steering wheel and push down on lever toward LH turn position. Check each position, HI, LO, OFF and INTERVAL positions.	If knob rotates from any of the positions, switch is damaged or worn. Replace switch.

TK8769D

Switch Continuity

Tools Required:

- Rotunda Digital Volt-Ohmmeter 007-00001

DIAGNOSIS AND TESTING (Continued)

Testing for electrical malfunctions can be accomplished using a continuity tester and an ohmmeter, such as Rotunda Digital Volt-Ohmmeter 007-00001 or equivalent.

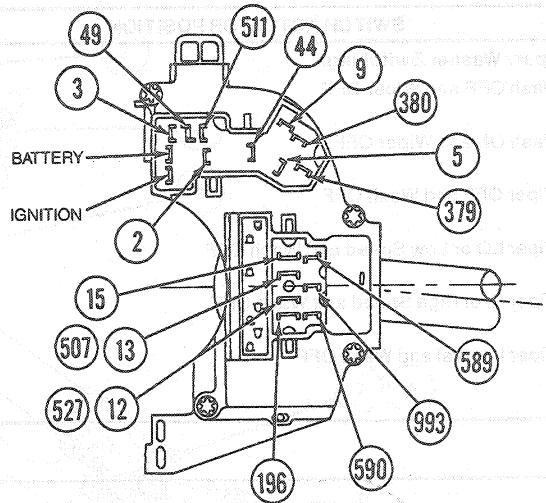

K14708-A

MULTI-FUNCTION SWITCH — BENCH CHECK CONTINUITY

SWITCH ACTUATOR POSITION	CONTINUITY BY CIRCUIT NUMBER
<p>Turn Signal Lever in Neutral — Hazard OFF</p> <p>Turn Signal Lever in Left Turn — Hazard OFF</p> <p>Turn Signal Lever in Right Turn — Hazard OFF.</p>	<p>Turn Signal: Closed 511 to 5 and 9; Ignition B+ to 49. Open 511 to 2, 3, 44 and 385; 44 to 2, 3, 5, 9 and 385; 385 to 2 and 3; Battery B+ to 49.</p> <p>Cornering Lamp: Open 15 to 379 and 380; 379 to 380.</p> <p>Turn Signal: Closed 511 to 5; 44 to 3 and 9; Ignition B+ to 49. Open 511 to 3, 9, 44 and 385; 44 to 2, 5 and 385; 385 to 2; Battery B+ to 49.</p> <p>Cornering Lamp: Closed 15 to 380. Open 15 to 379; 379 to 380.</p> <p>Turn Signal: Closed 511 to 9; 44 to 2 and 5; Ignition B+ to 49. Open 511 to 2, 5, 44 and 385; 44 to 3, 9 and 385; 385 to 2; Battery B+ to 49.</p> <p>Cornering Lamp: Closed 15 to 380. Open 15 to 379; 379 to 380.</p>
<p>Hazard ON</p> <p>Hazard OFF Turn Signal Lever, Right Turn</p>	<p>Closed 44 to 2, 3, 5 and 9; Battery B+ to 49. Open 511 to 5, 9, 44, 2 and 3; Ignition B+ to 49.</p> <p>Closed 511 to 9; 44 to 2 and 5; 15 to 379. Open 511 to 2, 5, 44 and 385; 44 to 3, 9 and 385; 385 to 2.</p>
<p>Headlamp Beam Switching:</p> <ul style="list-style-type: none"> ●Lever at High Beam ●Lever at Low Beam ●Lever at FLASH-TO-PASS 	<p>Closed 15 to 12. Open 15 to 13 and 196; 196 to 12.</p> <p>Closed 15 to 13. Open 15 to 12 and 196; 196 to 13.</p> <p>Closed 15 to 13; 196 to 12. Open 15 to 12; 196 to 13.</p>
<p>Auto Dim Switching:</p> <ul style="list-style-type: none"> ●Lever in Auto Dim Position ●Lever in Low Beam ●Lever in Flash-to-Pass 	<p>Closed 15 to 507. Open 15 to 527 and 196; 527 to 196.</p> <p>Closed 15 to 13. Open 15 to 527 and 196; 527 to 196.</p> <p>Closed 196 to 527. Open 15 to 527, 507 and 196; 527 to 507; 507 to 196.</p>

(Continued)

DIAGNOSIS AND TESTING (Continued)

MULTI-FUNCTION SWITCH — BENCH CHECK CONTINUITY (Cont'd)

SWITCH ACTUATOR POSITION	CONTINUITY BY CIRCUIT NUMBER
Wiper/Washer Switching: ●Wash OFF and Wiper OFF ●Wash ON and Wiper OFF ●Wiper OFF and Wash OFF ●Wiper LO or Low Speed and Wash OFF ●Wiper HI or High Speed and Wash OFF ●Wiper Interval and Wash OFF	Resistance 993 to 590, 103.3K ohms \pm 10%. Resistance 993 to 589, 47.6K ohms \pm 10%. Closed 993 to 590; Resistance 993 to 589, 47.6K ohms \pm 10%. Resistance 993 to 590, 103.3K ohms \pm 10%. Resistance 993 to 589, 47.6K ohms \pm 10%. Resistance 993 to 590, 3.3K ohms \pm 10%. Resistance 993 to 589, 4.08K ohms \pm 10%. Resistance 993 to 590, 3.3K ohms \pm 10%. Closed 993 to 589. Resistance 993 to 589, 11.33K ohms \pm 10%. Resistance 993 to 590. Gradually decreasing from 103.3K ohms to 3.3K ohms from Maximum Delay to Minimum Delay.

TK8772F

REMOVAL AND INSTALLATION

Switch, Ignition

Removal

1. Disconnect battery ground cable. Remove the steering column shroud by removing the four or five self-tapping screws. Remove tilt lever (if so equipped).
2. Remove instrument panel lower steering column cover.
3. Disconnect the ignition switch electrical connector.
4. Rotate ignition key lock cylinder to the RUN position.
5. Remove the two screws retaining ignition switch.
6. Disengage the ignition switch from the actuator.

Installation

NOTE: A new replacement switch assembly will be set in the RUN position as received.

1. Adjust the ignition switch by sliding the carrier to the switch RUN position.
2. Check to ensure that the ignition key lock cylinder is in the RUN position. The RUN position is achieved by rotating the key lock cylinder approximately 90 degrees from the LOCK position.
3. Install the ignition switch pin into the actuator. It may be necessary to move the switch slightly back and forth to align the switch mounting holes with the column lock housing threaded holes.
4. Install retaining screws. Tighten to 5.6-7.9 N·m (50-69 lb-in).
5. Connect electrical connector to ignition switch.
6. Connect battery ground cable. Check ignition switch for proper function, including START and ACC positions. Also, make certain that the column is locked in the LOCK position.

7. Install instrument panel lower steering column cover.
8. Install the steering column trim shrouds and tilt lever (if so equipped).

Switch, Multi-Function

Removal

1. Disconnect battery ground cable.
2. Tilt column to lowest position and remove tilt lever.
3. Remove ignition lock cylinder as outlined.
4. Remove shroud screws and remove upper and lower shroud.
5. Remove two self-tapping screws that attach multi-function switch to steering column casting. Disengage switch from casting.
6. Disconnect the two electrical connectors.

Installation

1. Install two electrical connectors to full engagement.
2. Align multi-function switch mounting holes with corresponding holes in the steering column casting. Install two self-tapping screws making sure to start the screws in the previously tapped holes. Tighten to 2-3 N·m (17-26 lb-in).
3. Install upper and lower steering column shroud with screws.
4. Install ignition lock cylinder as outlined.
5. Attach tilt lever.
6. Connect battery ground cable.
7. Check steering column and switch for proper operation.

REMOVAL AND INSTALLATION (Continued)

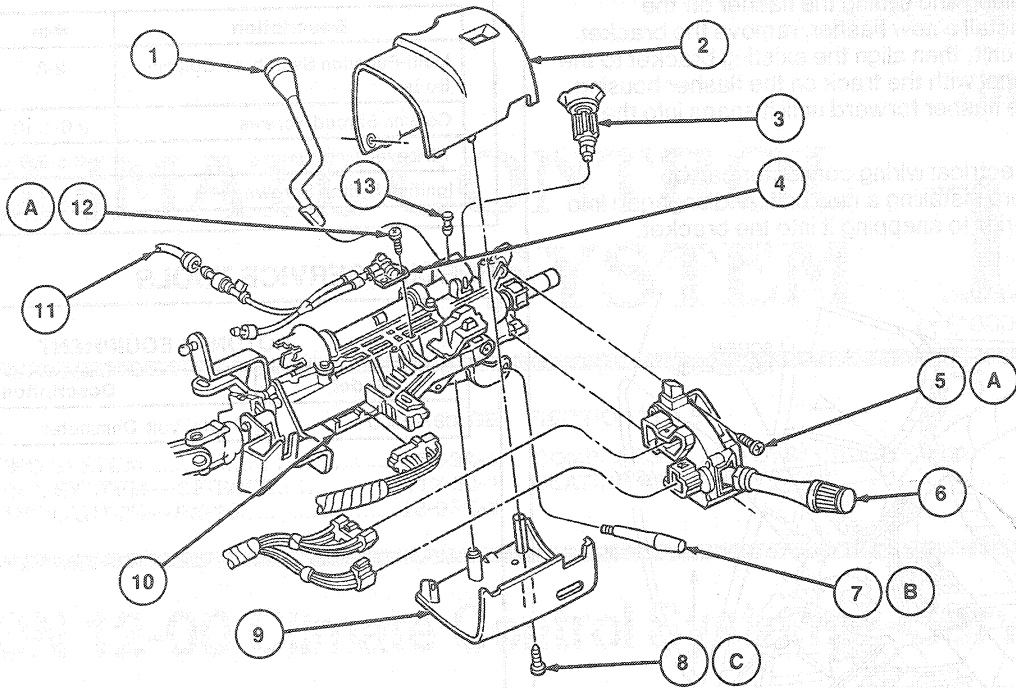

K13999-B

Item	Part Number	Description
1	7202	Shift Lever Assy
2	3530	Upper Shroud
3	11A606	Ignition Lock Assy
4	2B623	Park Brake Release Assy
5A	390345-S36	Screw (2 Req'd)
6	13K359	Switch Assy
7B	3F609	Tilt Lever
8C	55929-S2	Screw (4 Req'd)
9	3533	Lower Shroud

Item	Part Number	Description
10	11572	Ignition Switch
11	2B653	Hose
12A	390345-S36	Screw (2 Req'd)
13	7G357	Pin
A		Tighten to 2-3 N·m (17-26 Lb·In)
B		Tighten to 3.5-5.0 N·m (30-44 Lb·In)
C		Tighten to 0.6-1.13 N·m (6-10 Lb·In)

(Continued)

Flasher Unit

Removal and Installation

The turn signal flasher is located on the LH side of the instrument panel, and is retained by one screw to the lower instrument panel reinforcement.

REMOVAL AND INSTALLATION (Continued)

The combination turn signal and hazard flasher can be removed by tilting and sliding the flasher off the bracket. To install a new flasher, remove the bracket from the new unit, then align the existing bracket to the instrument panel with the track on the flasher housing. Then push the flasher forward until it snaps into the bracket.

NOTE: The electrical wiring connector can be removed before installing a new unit, and engaged into the new unit prior to snapping it into the bracket.

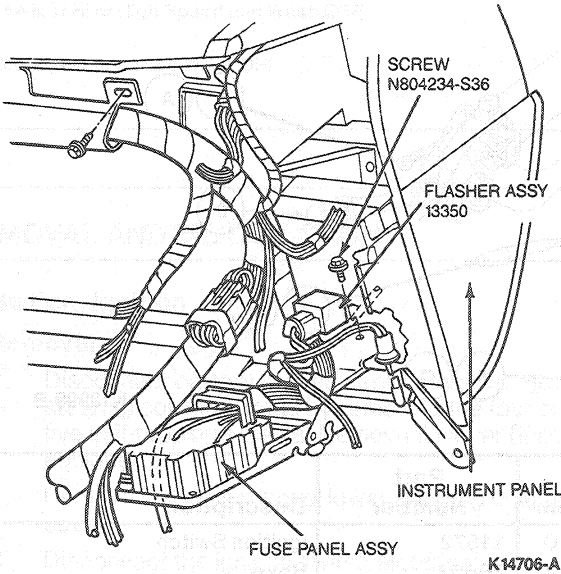

SPECIFICATIONS

TORQUE SPECIFICATIONS

Description	N-m	Lb-In
Multi-Function Switch -to-Column Bolts	2-3	17-26
Column Shroud Screws	0.6-1.13	6-10
Tilt Lever	3.5-5.0	30-44
Ignition Switch Screws	5.6-7.9	50-69

SPECIAL SERVICE TOOLS

ROTUNDA EQUIPMENT

Model	Description
007-00001	Digital Volt-Ohmmeter