

# EXHAUST SYSTEM

GROUP

# 09

(5000)

## SECTION 09-00 Exhaust System

SUBJECT	PAGE	SUBJECT	PAGE
<b>DESCRIPTION</b>		<b>REMOVAL AND INSTALLATION (Cont'd.)</b>	
Exhaust Shields .....	09-00-2	3.8L Multiport Fuel Injection (MFI) and 3.2L SHO .....	09-00-3
<b>GENERAL INFORMATION</b> .....	09-00-1	<b>SPECIFICATIONS</b> .....	09-00-11
<b>REMOVAL AND INSTALLATION</b>		<b>VEHICLE APPLICATION</b> .....	09-00-1
3.0L Multiport Fuel Injection (MFI), 3.0L SHO and 3.8L Police Engines .....	09-00-2		

### VEHICLE APPLICATION

Taurus / Sable and Taurus SHO.

### GENERAL INFORMATION

This Section covers the general exhaust system, adjustments and service procedures. Always refer to the Master Parts catalog for parts usage and interchangeability before replacing a component part of the exhaust system.

The exhaust system must be free of leaks, binding, grounding and excessive vibrations. These conditions are usually caused by loose, broken or misaligned clamps, shields, brackets or pipes. If any of these conditions exist, check the exhaust system components and alignment. Adjust or replace, as necessary, to maintain the specified clearances (refer to the illustrations in this Section). Brackets, clamps and insulators should be replaced if they are damaged or badly corroded. Do not attempt to service these parts.

Inspect the inlet pipe(s), outlet pipe(s), catalytic converters and muffler for cracked joints, broken welds, and corrosion damage that would result in a leaking exhaust system. Inspect the clamps, brackets, and insulators for cracks and stripped or badly corroded bolt threads.

When pipe clamp(s) is loosened and / or removed to replace a pipe, muffler or resonator, replace the clamp(s).

### DESCRIPTION

The 3.0L 49 States and Canada engine is equipped with a single resonator, single muffler, single catalytic converter and interconnecting pipes.

The 3.0L California and 3.0L FF Vehicle engines are equipped with a two can catalytic converter, a single resonator, single muffler and interconnecting pipes.

The 3.0L and 3.2L SHO engine uses a two can catalytic converter, a single resonator and dual mufflers.

The 3.8L engine is equipped with a muffler and resonator plus a two can catalytic converter system and interconnecting pipes.

**DESCRIPTION (Continued)**

The 3.8L Police Package uses a two can catalytic converter, a single resonator and dual mufflers.

The production exhaust system shown differs from the service replacement system in the number of basic pieces used.

**WARNING: THE NORMAL OPERATING TEMPERATURE OF THE EXHAUST SYSTEM IS VERY HIGH. NEVER ATTEMPT TO SERVICE ANY PART OF THE SYSTEM UNTIL IT HAS COOLED. BE ESPECIALLY CAREFUL WHEN WORKING AROUND THE CATALYTIC CONVERTER. THE TEMPERATURE OF THE CONVERTER RISES TO A HIGH LEVEL AFTER ONLY A FEW MINUTES OF ENGINE OPERATION.**

**Exhaust Shields****Service and / or Replacement**

Exhaust shields, consisting of formed metal sheets, attach to the exhaust system or the catalytic converter using various methods. Exhaust shields are not subject to service other than replacing missing or damaged attaching parts such as clamps or screws, and removing debris that may collect in the shield area. If an exhaust shield is damaged or shows evidence of deterioration, it must be replaced rather than serviced.

The catalyst welded shields are to be replaced with clamp-on service shields.

Removal and installation procedures are, in most cases, a matter of removing the shield attachments and shield. Installation is the reverse process, using new parts. The illustrations indicate the types and proper positioning of exhaust shields and clamps.

**REMOVAL AND INSTALLATION**

**WARNING: THE NORMAL OPERATING TEMPERATURE OF THE EXHAUST SYSTEM IS VERY HIGH. NEVER WORK AROUND OR ATTEMPT TO SERVICE ANY PART OF THE EXHAUST SYSTEM UNTIL IT HAS COOLED. USE SPECIAL CARE WHEN WORKING AROUND THE CATALYTIC CONVERTER. THESE UNITS HEAT TO A HIGH TEMPERATURE AFTER ONLY A SHORT PERIOD OF ENGINE OPERATION.**

Typical factory-installed exhaust systems are shown in the illustrations.

Vehicle	Sedan	Station Wagon	Number of Converter Cans	Typical factory-installed exhaust systems are shown in the illustrations.			
				49S	Can.	Cal.	Alt.
Taurus / Sable 3.0L MFI (49 States)	X	X	1	X	X		X
Taurus 3.0L / 3.2L SHO	X		2	X	X	X	X
Taurus / Sable 3.8L MFI	X	X	2	X	X	X	X
Taurus / Sable 3.8L Police	X		2	X	X	X	X
Taurus / Sable 3.0L MFI-Calif	X	X	2			X	
Taurus / Sable 3.0 MFI Flexible Fuel (FF)	X		2	X	X	X	X

**3.0L Multiport Fuel Injection (MFI), 3.0L SHO and 3.8L Police Engines****Resonator Assembly****Removal**

1. Raise vehicle. Refer to Section 00-02.

2. Remove front resonator flange fasteners at flex joint and discard flex joint gasket. Loosen rear U-bolt connection.
3. Separate resonator inlet and outlet connections.
4. Remove resonator.

**REMOVAL AND INSTALLATION (Continued)****Installation**

1. Loosely install resonator to muffler.
2. Install new flex joint gasket.
3. Install resonator and muffler assembly to converter outlet flex joint.
4. Align exhaust system to specification. Ensure muffler and resonator are fully engaged. Tighten all nuts and bolts, starting at front of system, to specification. Refer to Exhaust illustration.
5. Check system for leaks and lower vehicle.

**Muffler Assembly****Removal**

1. Raise vehicle. Refer to Section 00-02.
2. Remove U-bolt assembly and rubber insulators from hanger brackets and remove muffler assembly. Slide muffler assembly rearward to disconnect it from resonator.
3. Replace any damaged parts.

**Installation**

1. Position muffler assembly and slide it onto resonator outlet pipe. Check to ensure slot in muffler and tab on resonator are fully engaged.
2. Install rubber insulators on hanger assemblies and install and tighten U-bolt to 34-46 N·m (26-33 lb-ft). Refer to illustration.
3. Check system for leaks and lower vehicle.

**Catalytic Converter, Under Engine Oil Pan****Removal**

1. Raise vehicle. Refer to Section 00-02.
2. Remove front and rear catalytic converter flange fasteners from exhaust manifolds and nut and bolt attachments at transmission.
3. Remove bolt and nut retainers at transmission case.
4. Remove two remaining nuts and bolts from catalytic converter outlet connection. Discard flex joint gasket.
5. Remove converter.

**Installation**

1. Loosely install converter to manifold connection.
2. Install bolt and nut retainers to converter and transmission.
3. Install new flex joint gasket.
4. Install converter to resonator assembly.
5. Align exhaust system to specification. Starting at front of system, tighten all nuts and bolts to specification. Refer to illustration.
6. Check system for leaks and lower vehicle.

**3.8L Multiport Fuel Injection (MFI) and 3.2L SHO****Muffler and Resonator Assembly****Removal**

1. Raise vehicle. Refer to Section 00-02.
2. Remove U-bolt assembly and rubber insulators from hanger brackets.
3. Slide assembly rearward to disconnect from flexible pipe.
4. Remove muffler and resonator assembly.

**Installation**

1. Position muffler and resonator assembly and slide forward onto flexible pipe outlet.
2. Install rubber insulators on hanger assemblies.
3. Install U-bolt and tighten to 34-46 N·m (26-33 lb-ft). Refer to illustration.
4. Check system for leaks and lower vehicle.

**Catalytic Converter, Engine Compartment****Removal**

1. Raise vehicle. Refer to Section 00-02.
2. Remove front and rear catalytic converter flange retaining nuts from exhaust manifold.
3. Remove bolt and nut retainers at transmission.
4. Remove two retaining nuts and bolts connecting catalytic converter to flexible pipe and discard flat gasket.
5. Remove catalytic converter.

**Installation**

1. Install converter to manifold connections.
2. Install bolt at transmission case.
3. Install nut at transmission case.
4. Install new flat gasket.
5. Install converter to flexible pipe.
6. Align exhaust system to specification. Starting at front of system, tighten all nuts and bolts to specification. Refer to illustration.
7. Check system for leaks and lower vehicle.

**Flexible Pipe****Removal**

1. Raise vehicle. Refer to Section 00-02.
2. Remove two retaining nuts and bolts that connect the flexible pipe to the catalytic converter flange. Remove and discard gasket.
3. Loosen U-bolt connection and slide flexible pipe from muffler / resonator inlet pipe.

**Installation**

1. Install flexible pipe into muffler / resonator inlet pipe.
2. Install new gasket.
3. Install retaining nuts and bolts to flexible pipe and converter flange.

### REMOVAL AND INSTALLATION (Continued)

4. Position U-bolt. Tighten to 34-46 N·m (26-33 lb-ft).

#### 3.8L MFI

5. Check system for leaks and lower vehicle.

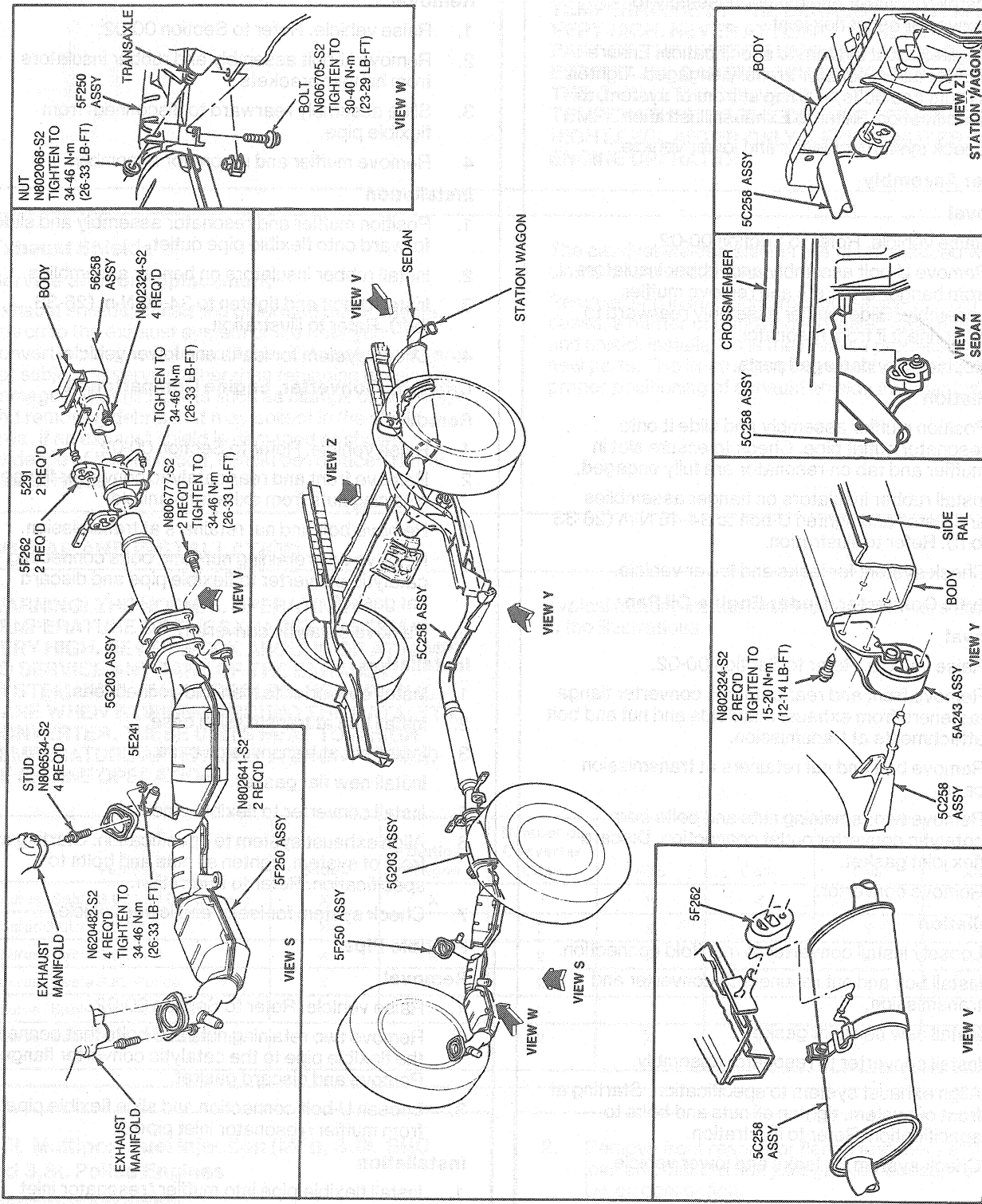

U2109-F





REMOVAL AND INSTALLATION (Continued)

3.0L SHO

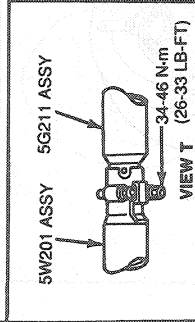
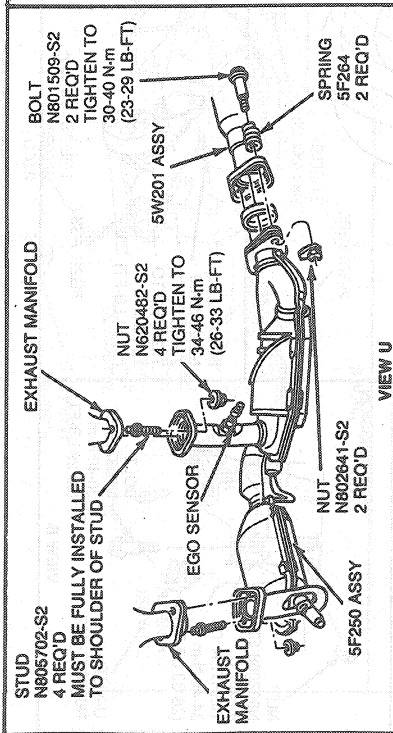
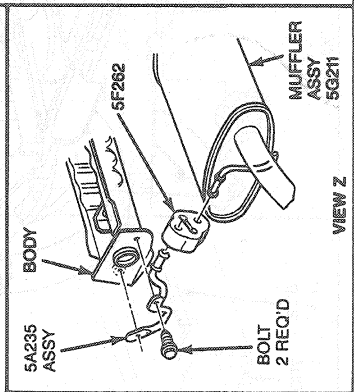
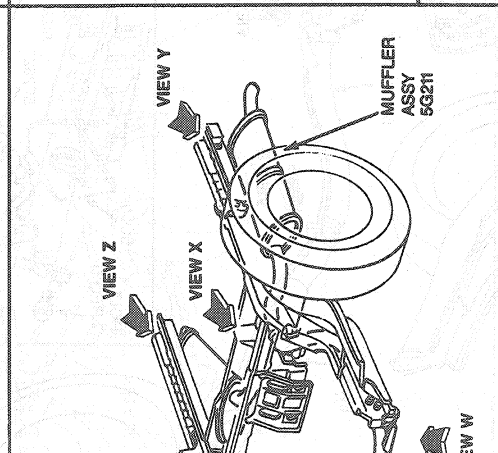
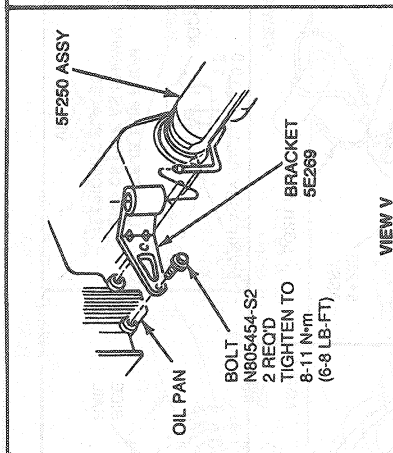
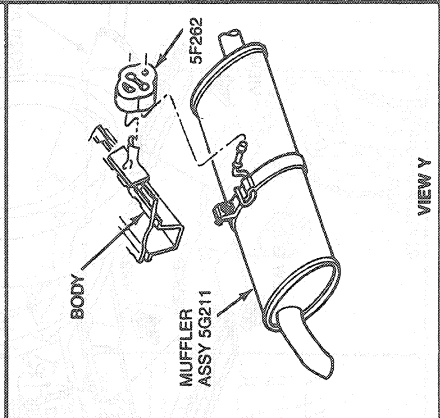
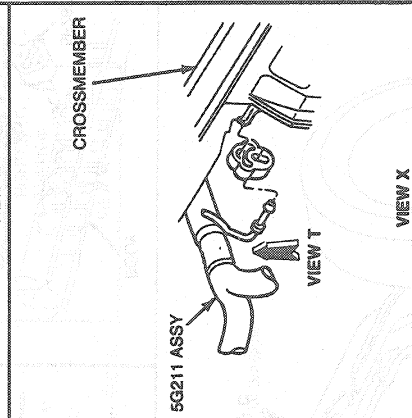
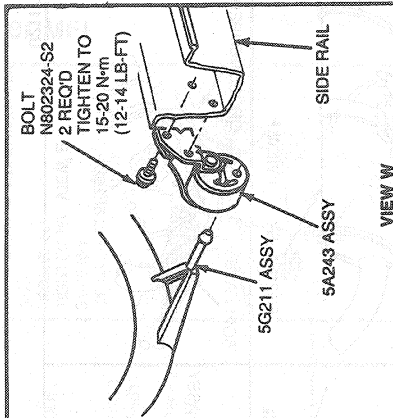

REMOVAL AND INSTALLATION (Continued)

3.2L SHO

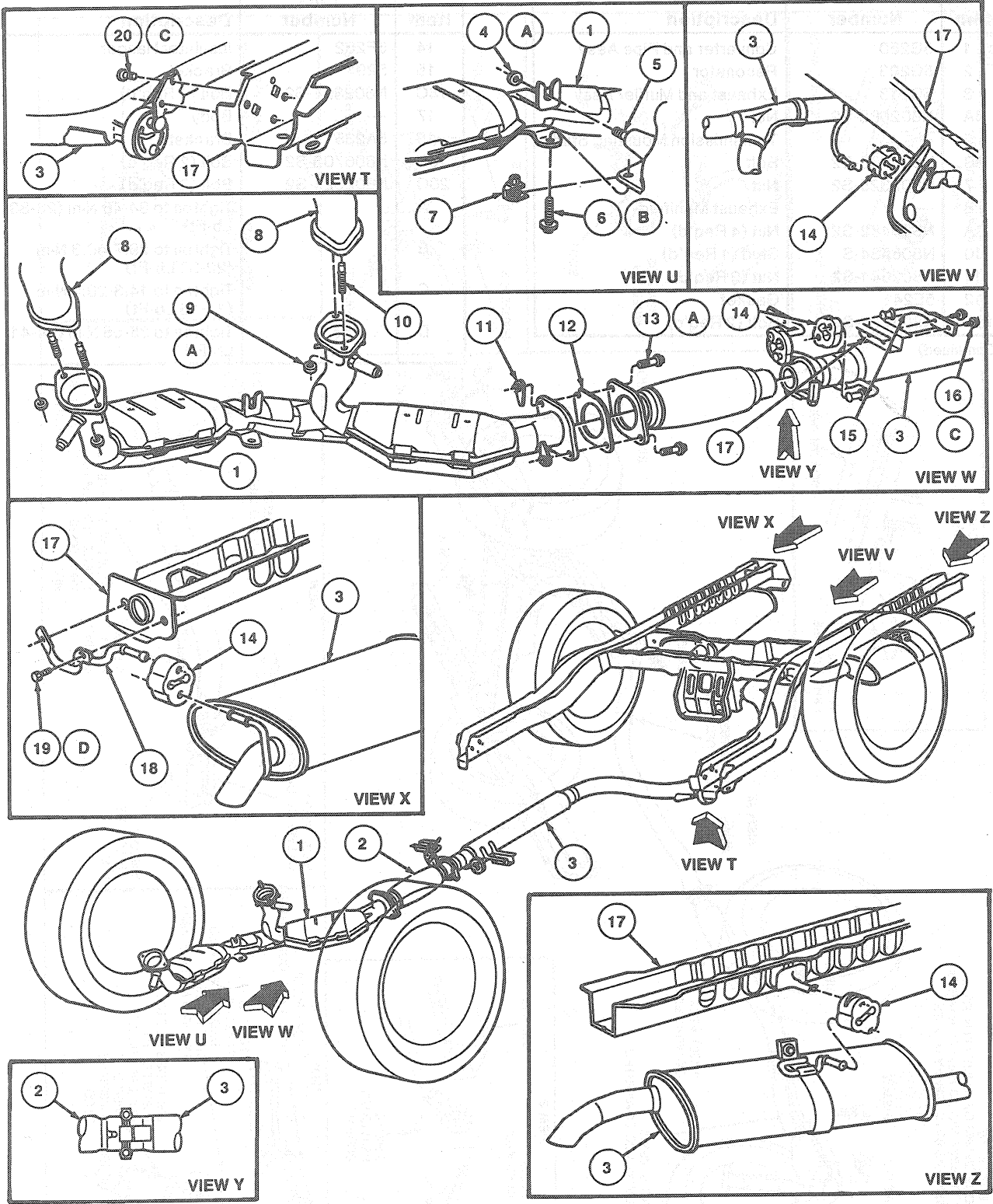

U2451-A

REMOVAL AND INSTALLATION (Continued)

(Continued)

Item	Part Number	Description
1	5G250	Converter and Pipe Assy
2	5G203	Resonator
3	5G213	Exhaust and Muffler Assy
4A	N802068-S2	Nut
5	—	Transmission Mounting Stud
6B	N606705-S2	Bolt
7	N807325-S2	Nut
8	—	Exhaust Manifold
9A	N620482-S2	Nut (4 Req'd)
10	N806534-S	Stud (4 Req'd)
11	N802641-S2	Nut (2 Req'd)
12	5E241	Gasket
13A	N806777-S2	Bolt (2 Req'd)

Item	Part Number	Description
14	5F262	Insulator Hanger
15	5291	Bracket
16C	N802324-S2	Bolt (4 Req'd)
17	—	Body
18	5A235	Bracket
19D	N606703-S2	Bolt (2 Req'd)
20C	N802324-S2	Bolt (2 Req'd)
A		Tighten to 34-46 N·m (26-33 Lb·Ft)
B		Tighten to 29.7-40.3 N·m (22-30 Lb·Ft)
C		Tighten to 14.8-20.2 N·m (11-15 Lb·Ft)
D		Tighten to 35-55 N·m (24-41 Lb·Ft)

(Continued)

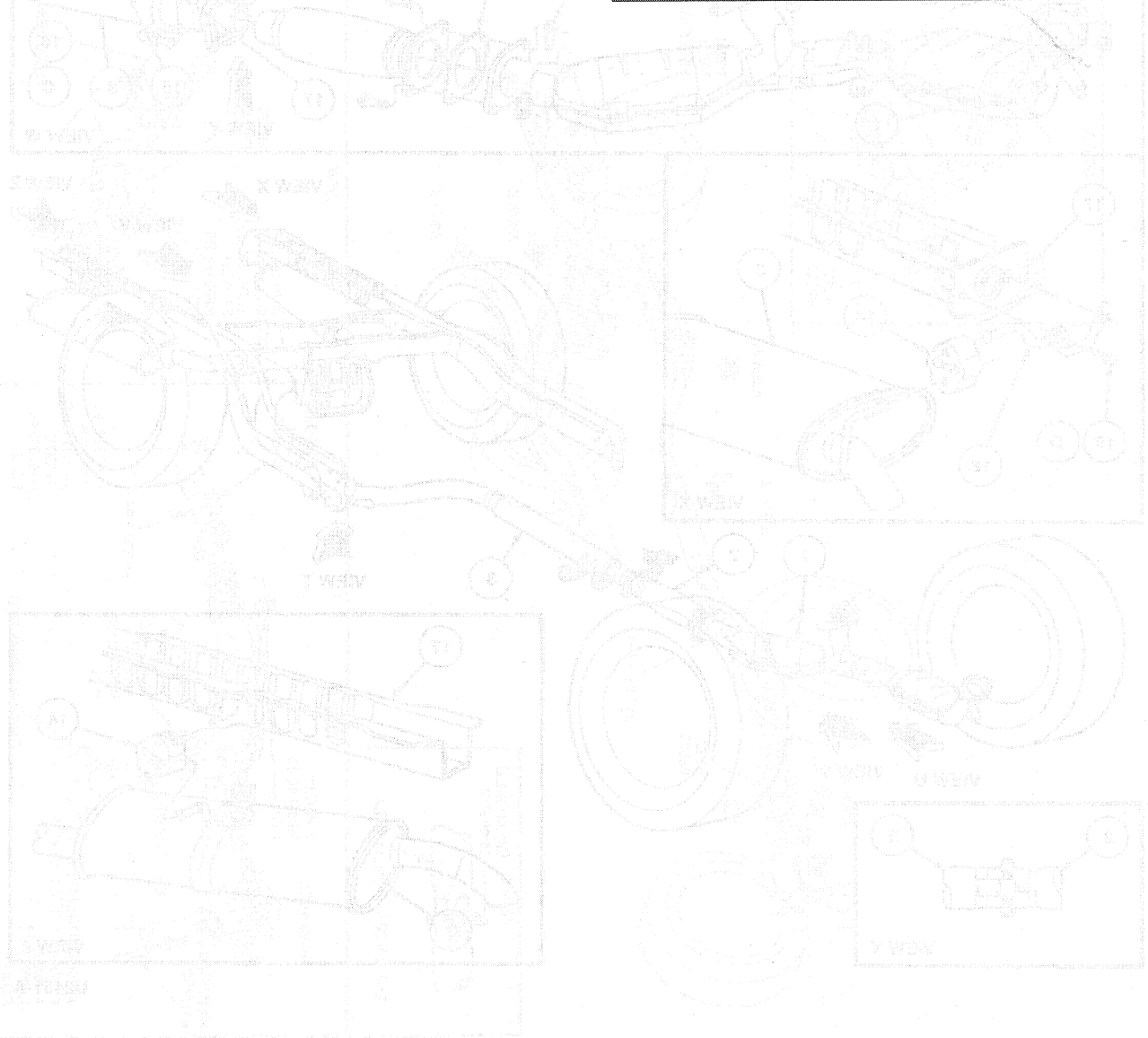



REMOVAL AND INSTALLATION (Continued)

3.0L MFI (49 States)

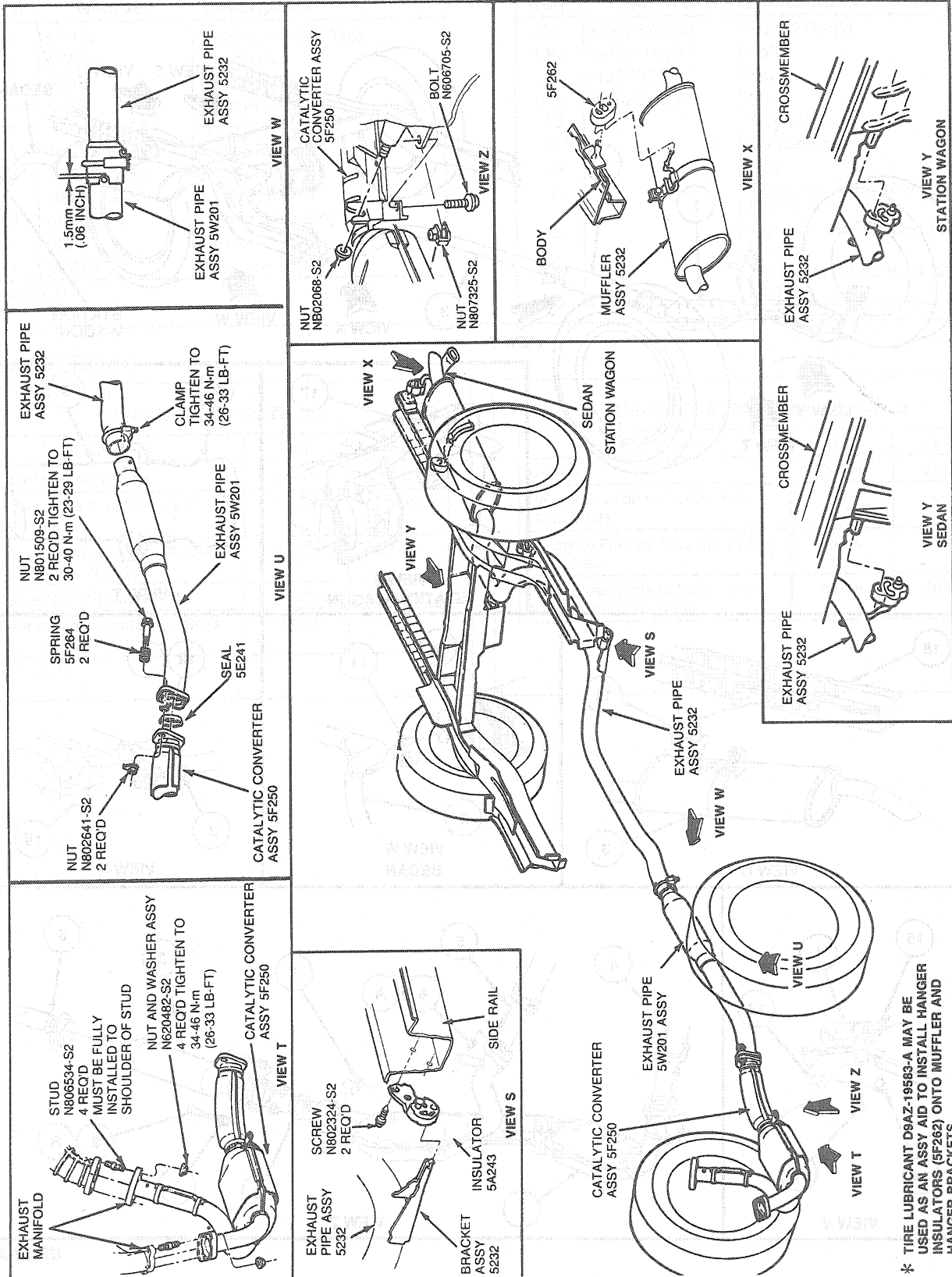

\* TIRE LUBRICANT D9AZ-19583-A MAY BE USED AS AN ASSY AID TO INSTALL HANGER INSULATORS (5F262) ONTO MUFFLER AND HANGER BRACKETS.

U2072-G

REMOVAL AND INSTALLATION (Continued)

3.0L MFI California Only

REMOVAL AND INSTALLATION (Continued)

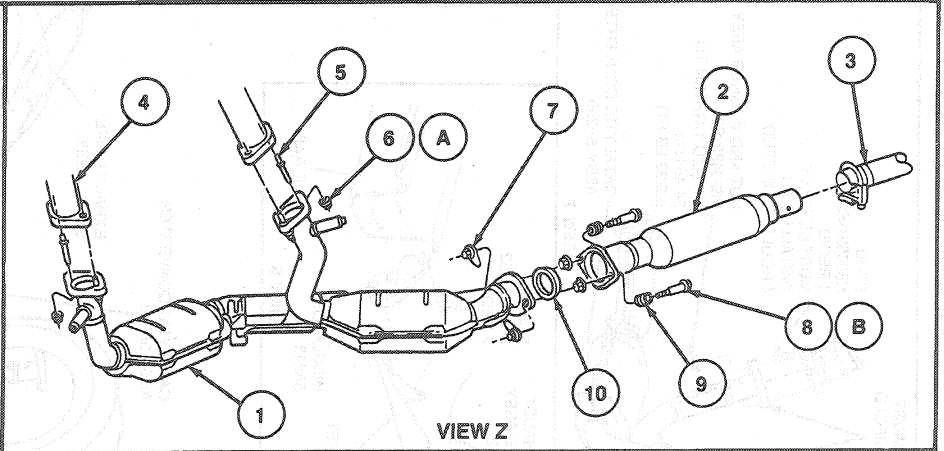
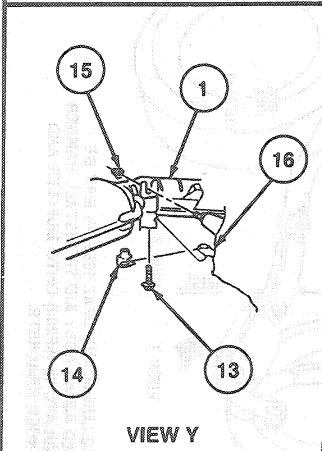
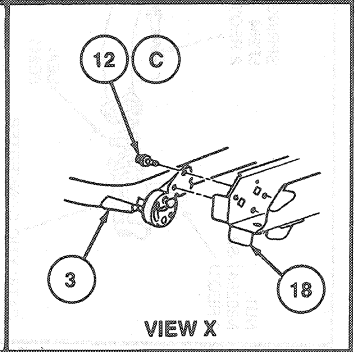
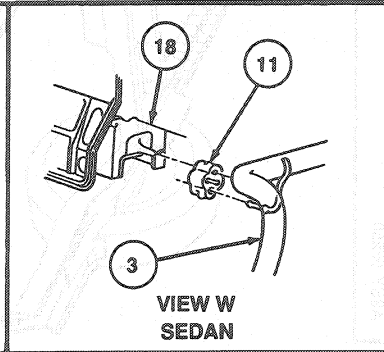
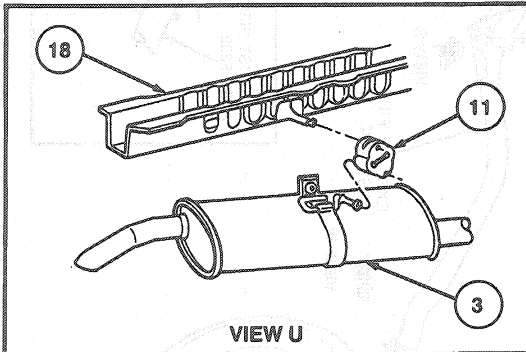
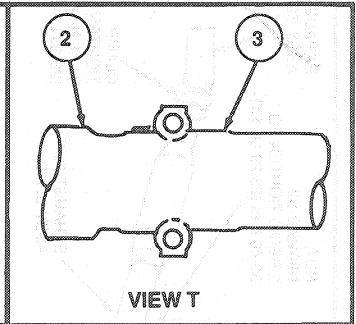
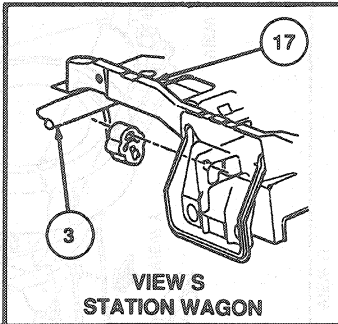
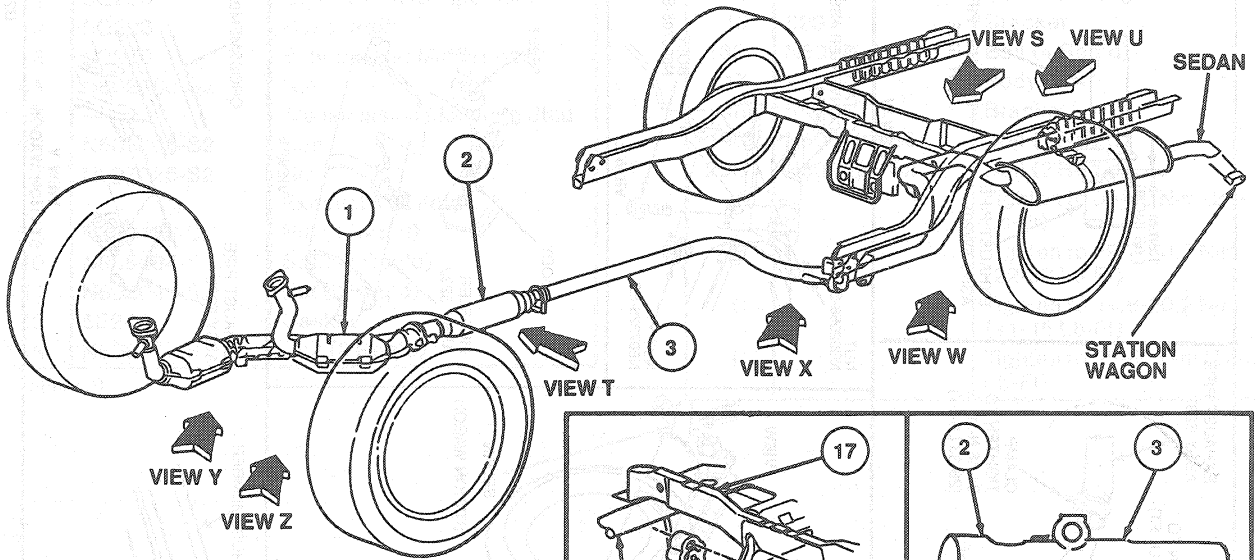

U2452-A

