

DISASSEMBLY AND ASSEMBLY (Continued)

3. Remove the fifth gear synchronizer assembly.

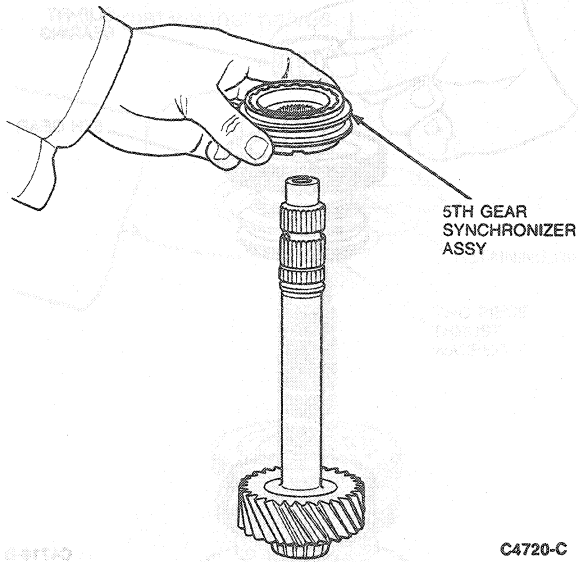

4. Remove the press fit bearing from the pinion end of the shaft, using Pinion Bearing Cone Remover D79L-4621-A or equivalent.

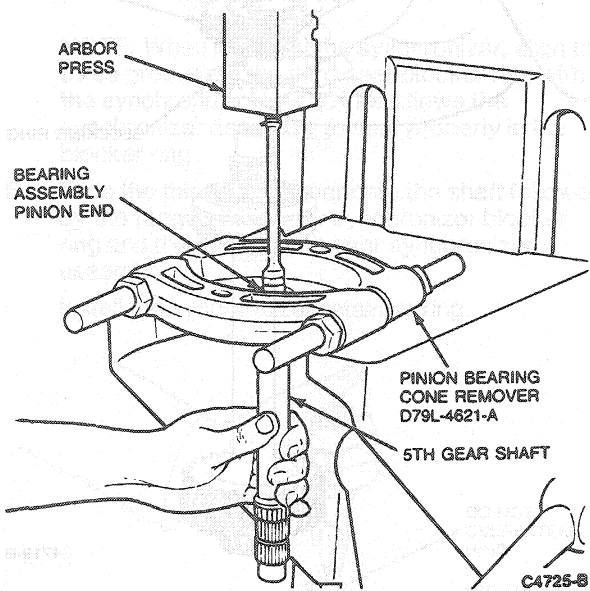

Assembly

NOTE: Prior to assembly, thoroughly clean all parts and inspect their condition. Lightly oil the gear bore with Synthetic MERCON® Multi-Purpose Automatic Transmission Fluid E6AZ-19582-B (ESR-M2C 163-A2) or equivalent.

1. Press the bearing onto the pinion gear end of the fifth gear shaft.

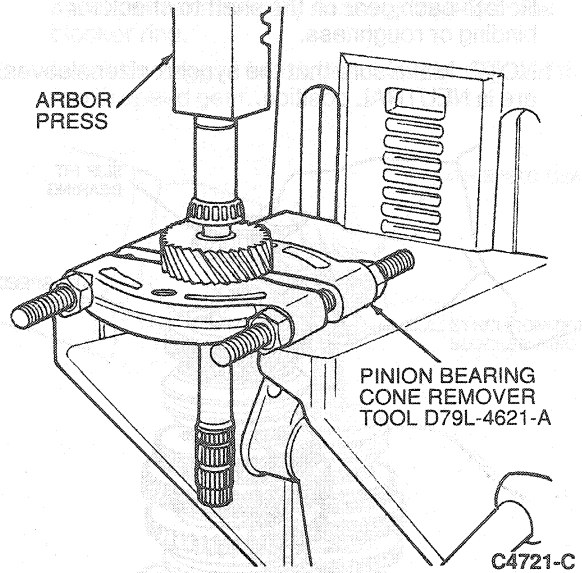

2. Install the fifth synchronizer assembly with the plastic insert retainer facing the pinion gear.

