

**DISASSEMBLY AND ASSEMBLY (Continued)**

63. Start remaining chain cover bolts and tighten 10mm bolts to 27-33 N·m (20-26 lb-ft). Tighten 8mm bolt to 9-12 N·m (7-9 lb-ft). Tighten 13mm bolt to 34-48 N·m (26-35 lb-ft). Tighten bolts in sequence shown.

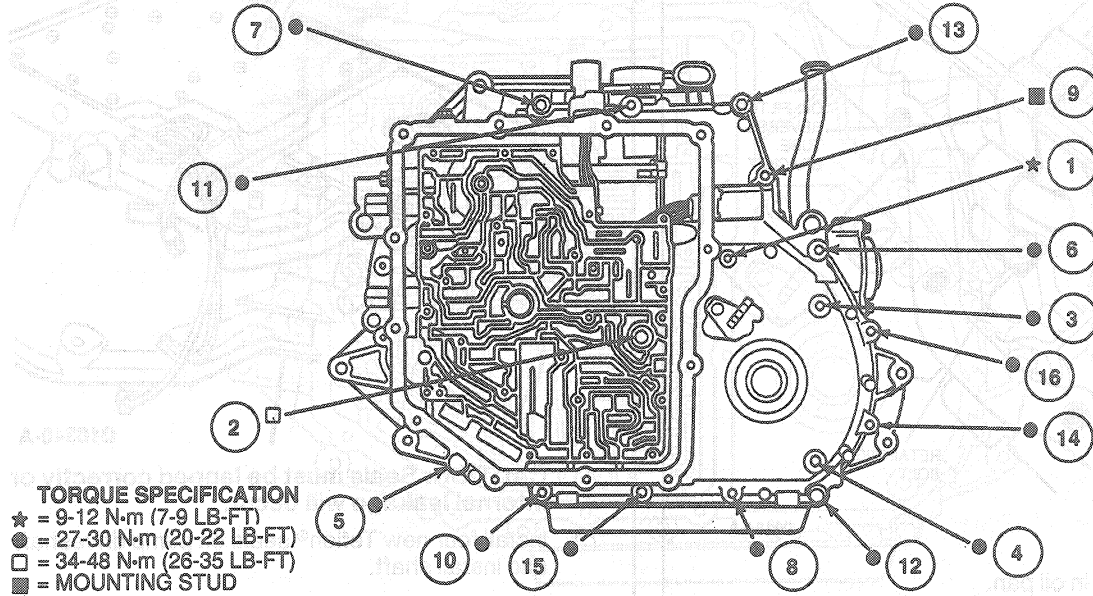

D8846-C

64. Tighten reverse drum 6mm Allen head anchor bolt to 10-12 N·m (7.5-9 lb-ft) and 19mm locknut to 34-47 N·m (26-35 lb-ft).

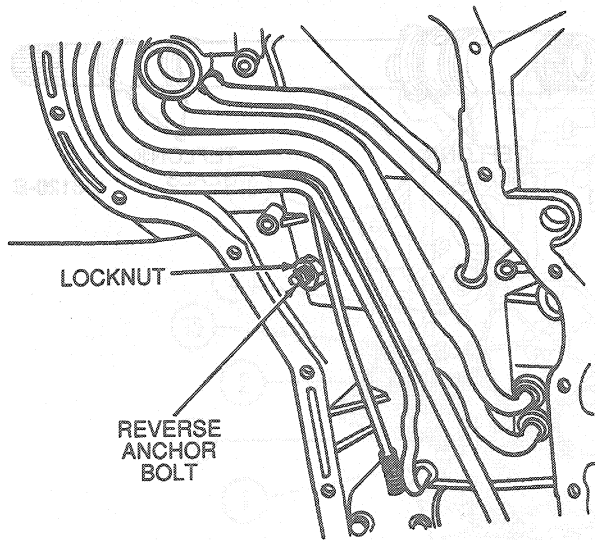

D11461-A

65. Install lip seal onto oil filter and press oil filter into case.

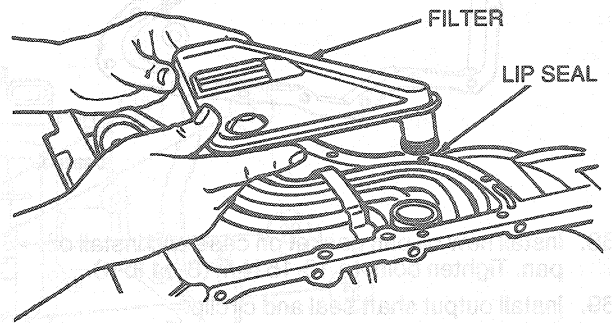

D10335-B