

DISASSEMBLY AND ASSEMBLY (Continued)

3.2L SHO

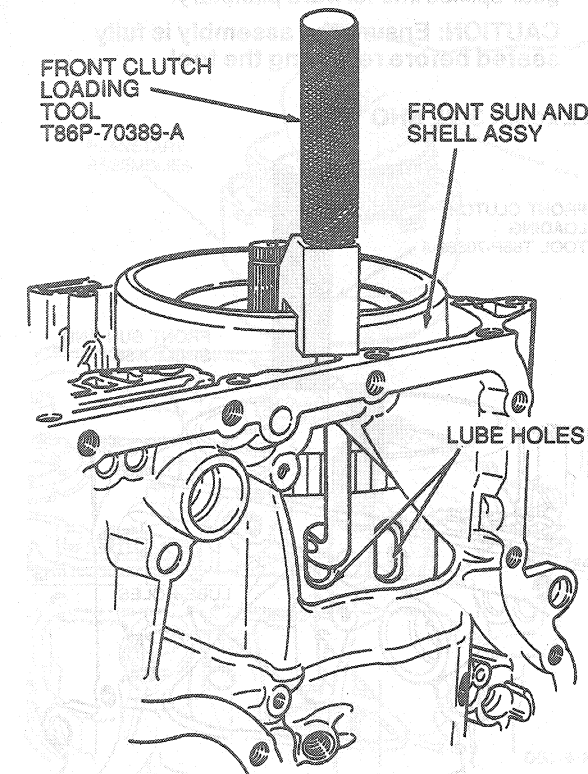

NOTE: MODIFY CLUTCH LOADING TOOL TO FIT LUBE HOLES BY REMOVING 0.50mm (0.02 INCH) OF MATERIAL OFF EACH SIDE OF TOOL.

D10586-A

22. Install overdrive band into case.

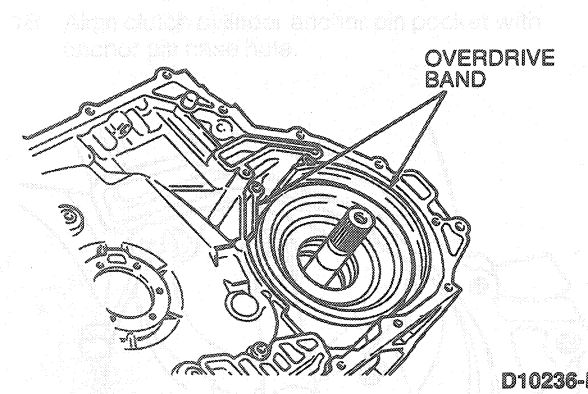

D10236-B

23. Install plastic retainer with cross hairs facing up.

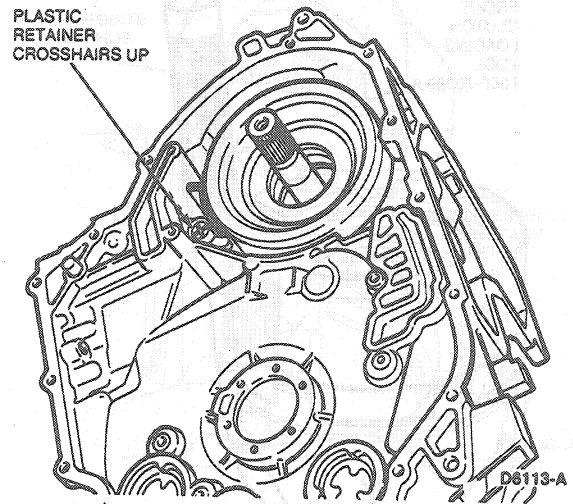

NOTE: Perform Steps 24 through 34 to check the driven sprocket end-play clearance for No. 8 selective thickness thrust washers.

24. Tighten screw on end-play tool previously installed to 4-5 N·m (35-44 lb-in).

25. Ensure that the No. 5 thrust washer is removed from the driven sprocket support.

NOTE: Make sure that all pieces are clean and dry. Do not use petroleum jelly for this step.

26. Install No. 8 thrust washer into No. 9 needle bearing.

27. Lower needle bearing / thrust washer assembly over the output shaft and carefully center the assembly.