

DISASSEMBLY AND ASSEMBLY (Continued)

16. Slide planetary assembly over output shaft.

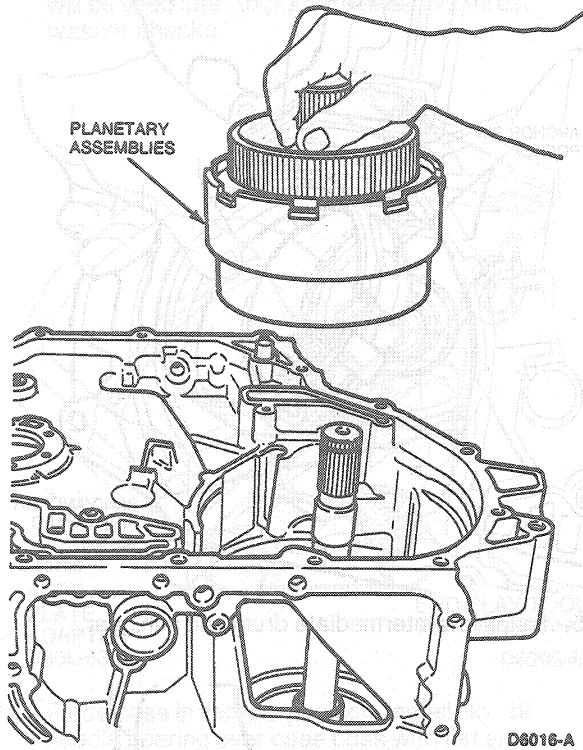

17. Lower reverse clutch into case. Ensure clutch plates have full engagement.

NOTE: To seat reverse clutch, the intermediate clutch hub can be used as a tool to complete clutch plate engagement. Rotating planet with hub will allow clutch splines to engage.

18. Align clutch cylinder anchor pin pocket with anchor pin case hole.

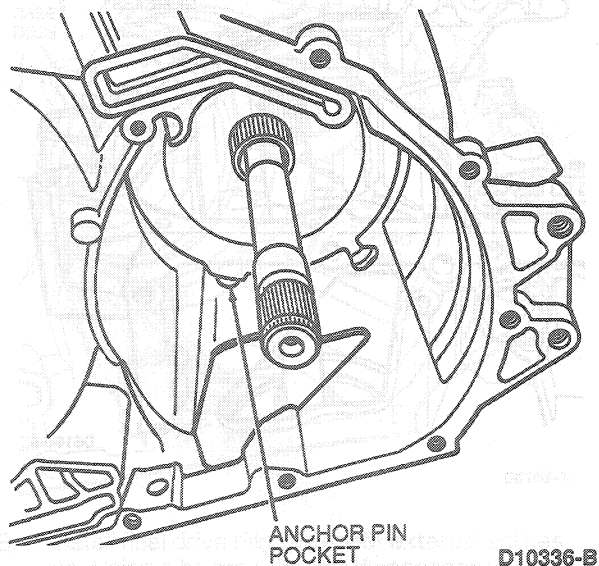

DISASSEMBLY AND ASSEMBLY (Continued)

INTERMEDIATE CLUTCH HUB

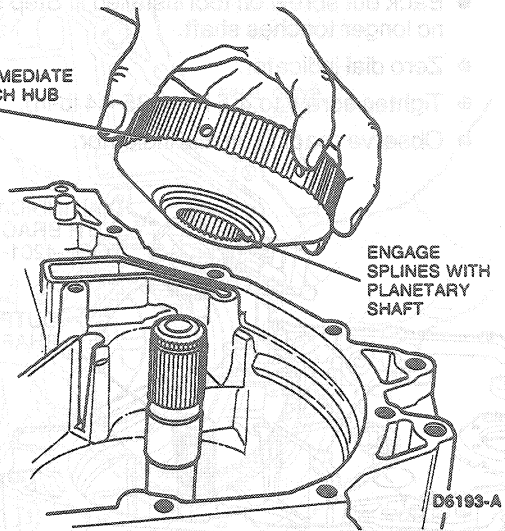

19. Start reverse anchor pin bolt but do not tighten at this time.

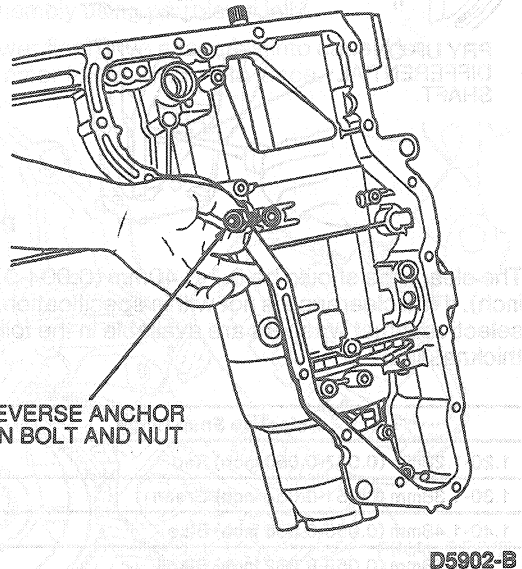

20. Attach Front Clutch Loading Tool T86P-70389-A to forward / intermediate / direct clutch assembly.