

DISASSEMBLY AND ASSEMBLY (Continued)

6. Loosely install End Play Tool T87P-70014-AH and two bolts over RH output shaft opening. Tool will be used later to perform selective thrust washer checks.

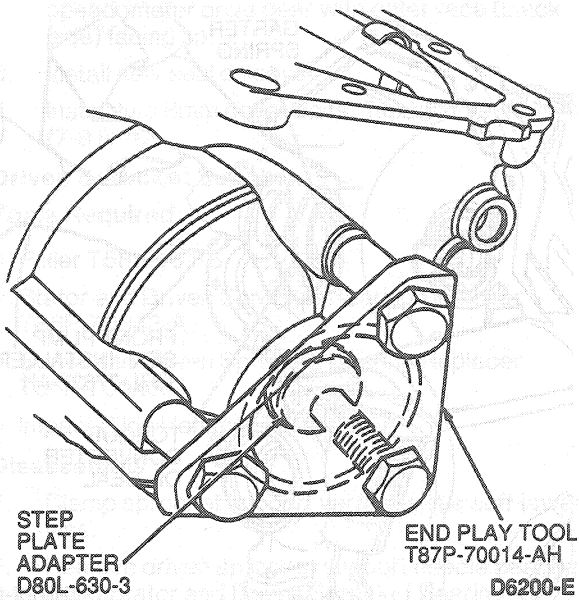

7. Place case in vertical position. Install No. 19 needle bearing over case boss with flat side facing up, outer lip facing down.

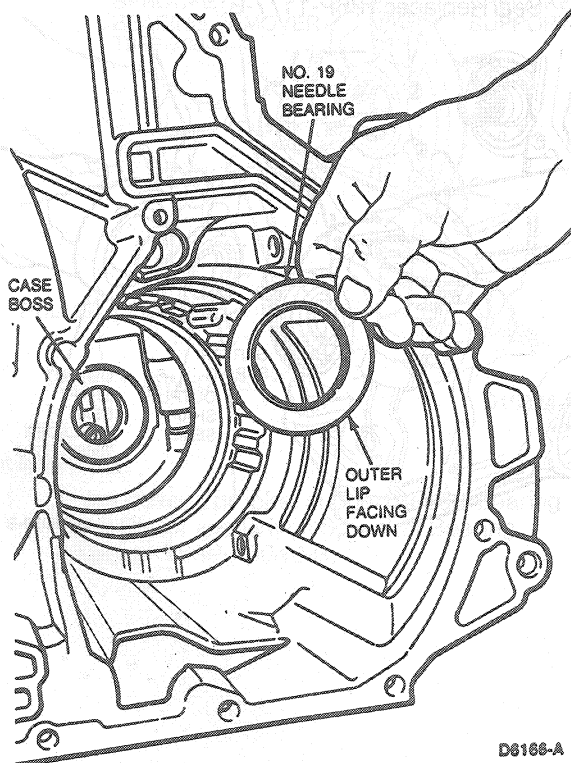

8. Install final drive ring gear with external splines up. Using a hammer handle if necessary, tap gently to fully seat into case splines.

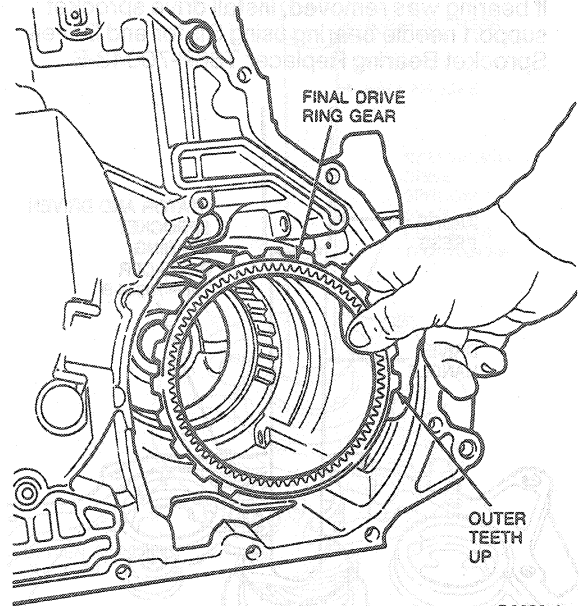

9. Assemble No. 18 thrust washer to differential assembly using petroleum jelly.
10. Lower final drive assembly into case. Use hammer to gently tap into place.

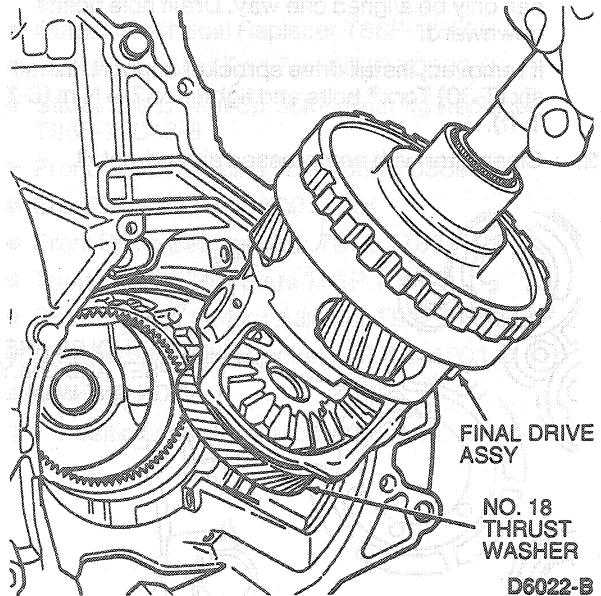

11. Install snap ring and align opening of snap ring with rear lube tube passage.
12. Perform end clearance check for No. 18 selective thrust washer as follows:
- Place screwdriver under differential case and pry up.
 - Mount Dial Indicator with Bracketry TOOL-4201-C or equivalent with stylus on end of output shaft.