

DISASSEMBLY AND ASSEMBLY (Continued)

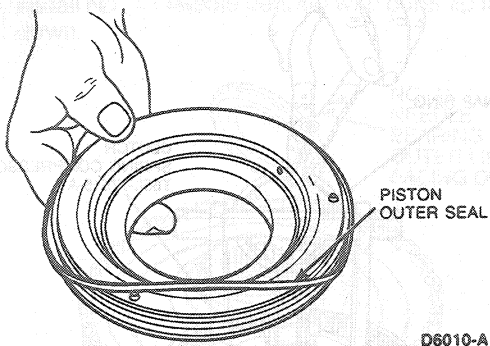

D6010-A

Assembly

1. Install inner and outer piston lip seals (lips facing toward bottom of cylinder) and install piston using Reverse Clutch Outer Lip Seal Protector T86P-70403-A.

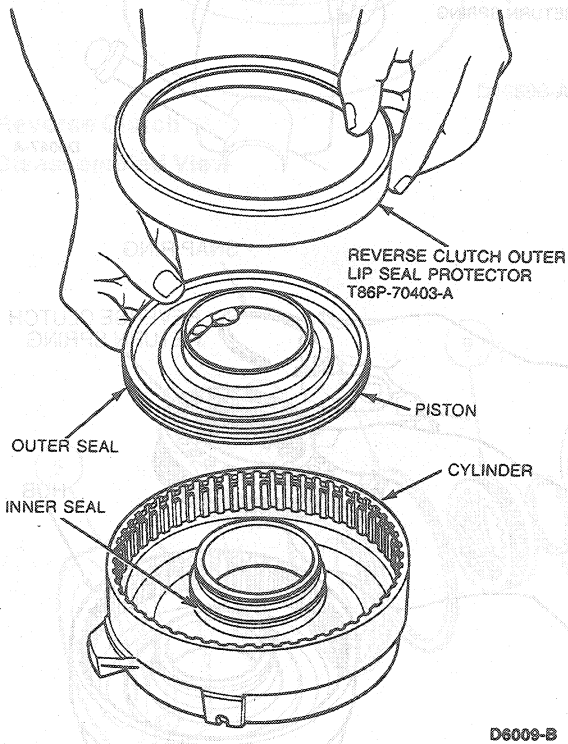

D6009-B

2. Install return spring .

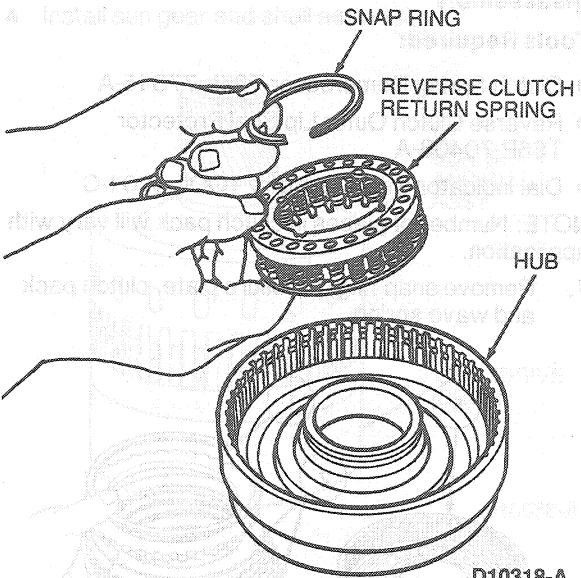

D10318-A

3. Compress return spring using Clutch Spring Compressor T65L-77515-A. Install snap ring.

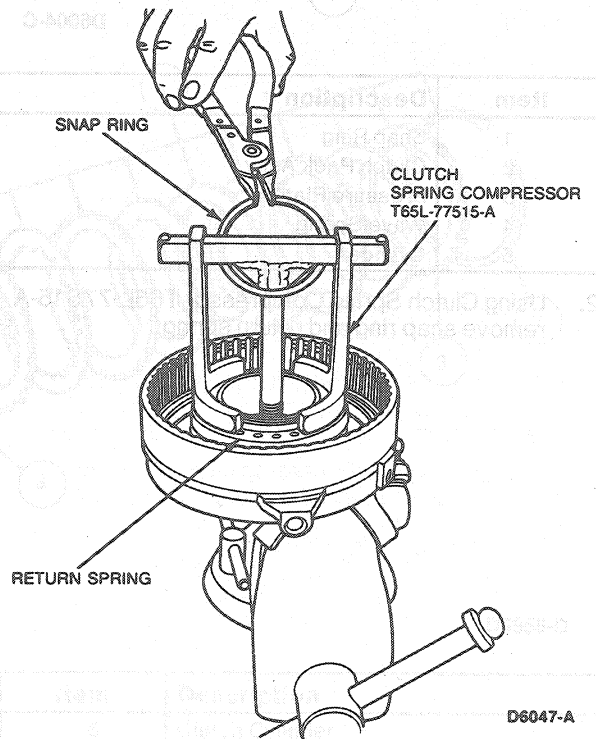

D6047-A

4. Install wave spring, clutch pack, pressure plate and snap ring.