

**DISASSEMBLY AND ASSEMBLY (Continued)**

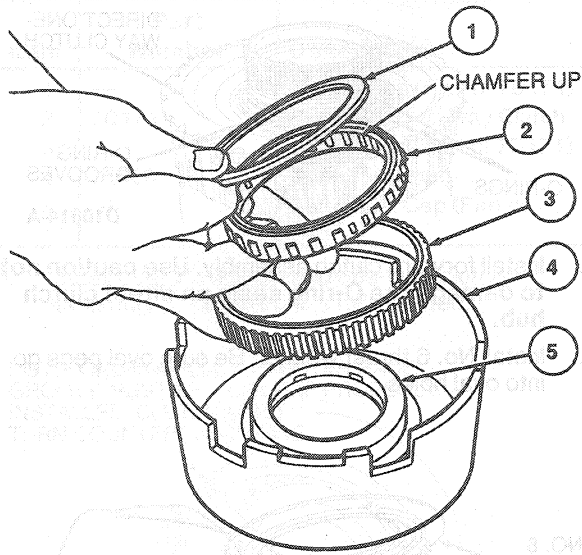

D10311-A

Item	Description
1	Top Cap
2	Overdrive One-Way Clutch
3	Outer Race
4	Overdrive Drum
5	Bottom Cap

9. Install overdrive drum and one-way clutch assembly. Ensure drum is fully seated.

NOTE: ONE-WAY CLUTCH OUTER RACE GROOVE MUST BE VISIBLE, IF PROPERLY INSTALLED. CLUTCH MUST TURN COUNTERCLOCKWISE

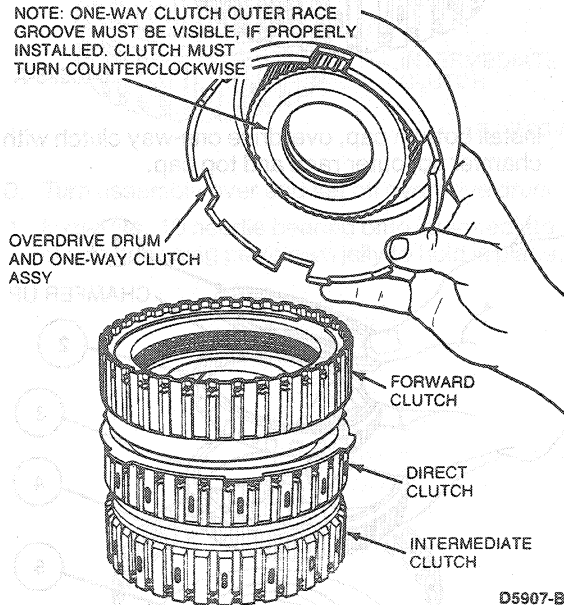

D5907-B

10. Turn assembly over and set on overdrive drum.
11. Install No. 10 needle bearing onto intermediate clutch hub using petroleum jelly to hold in place.
12. Install intermediate clutch hub with No. 10 needle bearing to ensure hub is fully seated.

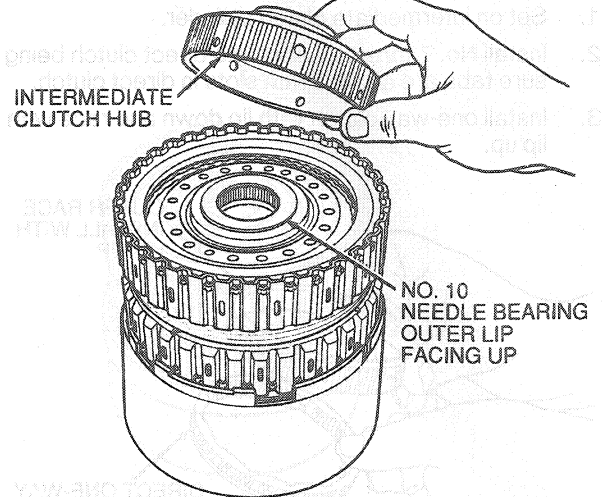

D6019-B

13. Install No. 11 needle bearing with outer lip facing down.

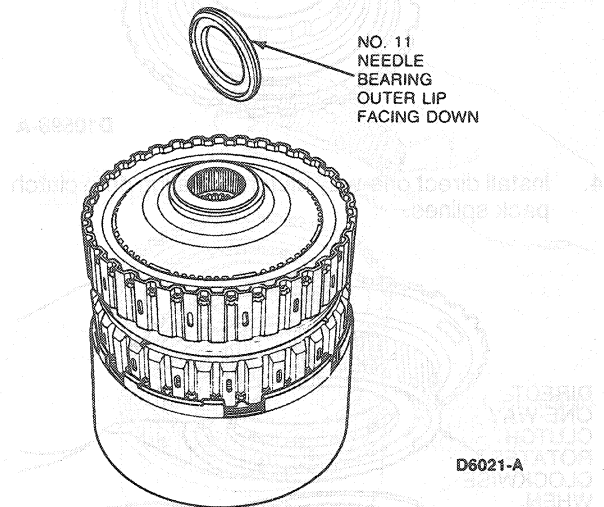

D6021-A

14. Install sun gear and shell assembly.

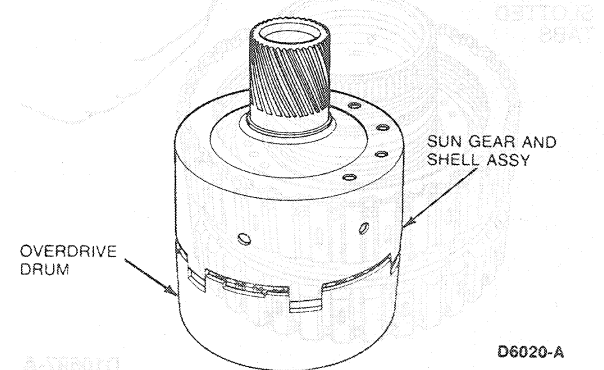

D6020-A