

**DISASSEMBLY AND ASSEMBLY (Continued)**

Selective Snap Rings
1.24-1.34mm (0.049-0.053 inch)
1.66-1.76mm (0.065-0.069 inch)
2.08-2.18mm (0.082-0.086 inch)
2.50-2.60mm (0.098-0.102 inch)
2.92-3.02mm (0.115-0.119 inch)

After installing the correct snap ring, check the clearance.

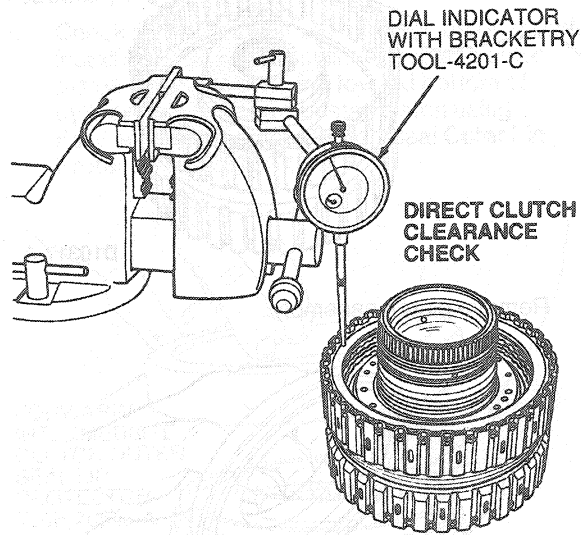

D5903-C

**Intermediate Clutch**  
All Except 3.2L SHO

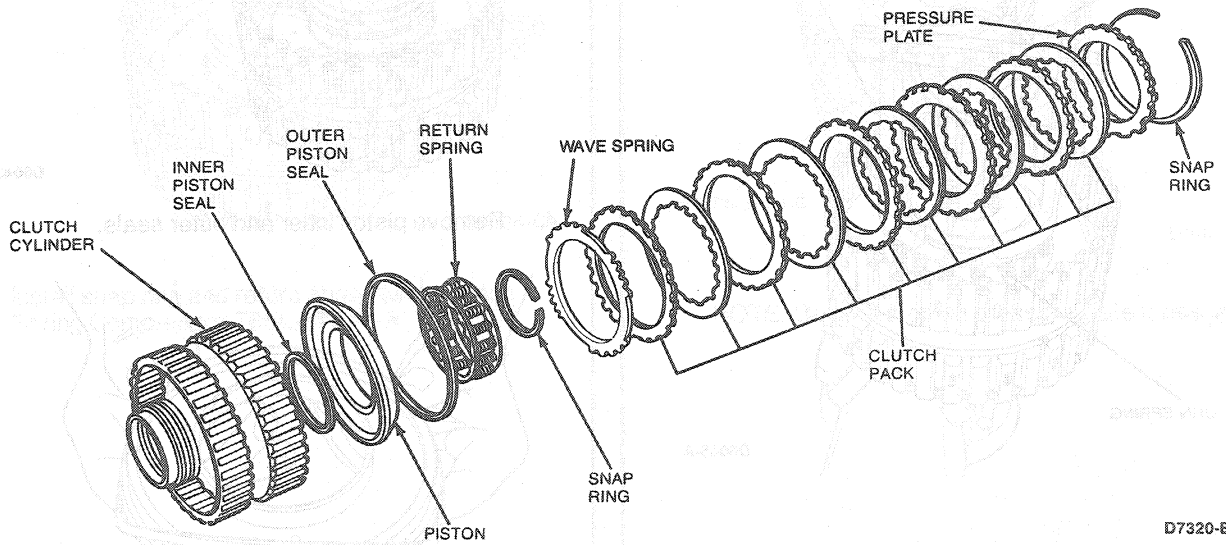

D7320-B

7. Install O-rings.

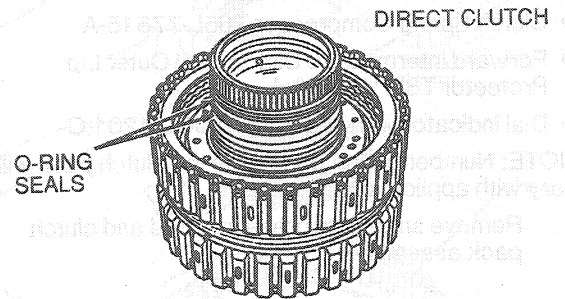

D11455-A