

DISASSEMBLY AND ASSEMBLY (Continued)

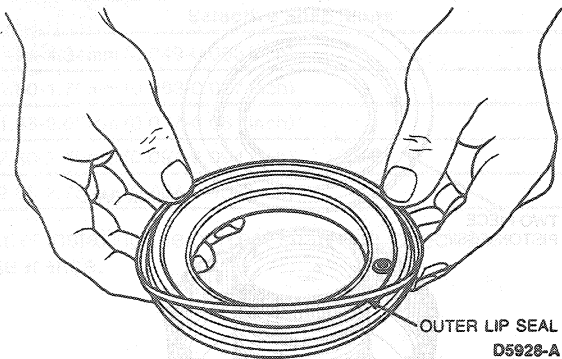

Assembly

1. Install inner and outer piston lip seals (lip seals facing toward bottom of cylinder) and install into hub using Direct Clutch Lip Seal Protector T86P-70234-A. Be sure piston is seated fully.

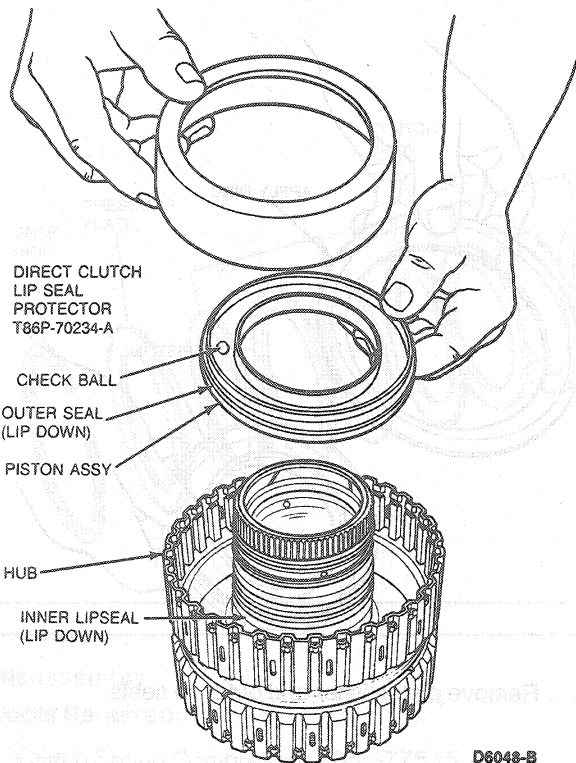

2. Install piston apply ring.

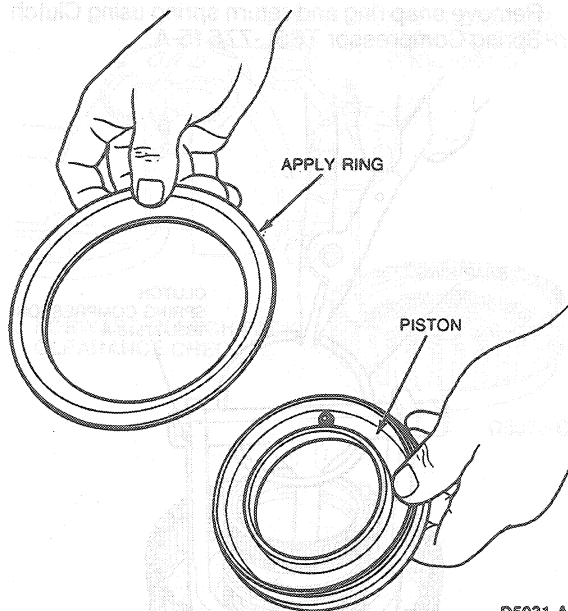

3. Verify free movement of check ball.
4. Install return spring in cylinder aligning return spring notch with check ball in piston.

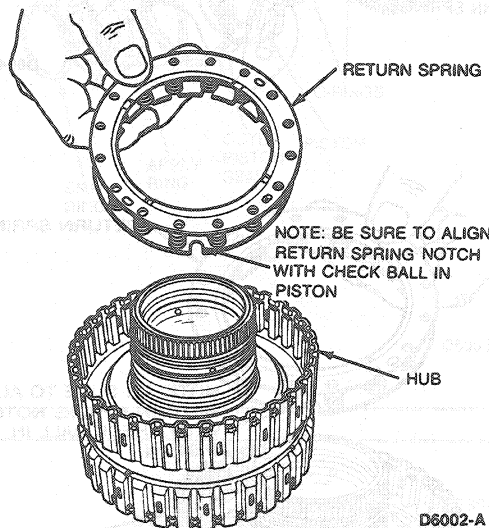

CAUTION: Do not allow tool to bottom out on piston assembly.