

DISASSEMBLY AND ASSEMBLY (Continued)

5. Install outer vane support.

VANE OUTER SUPPORT

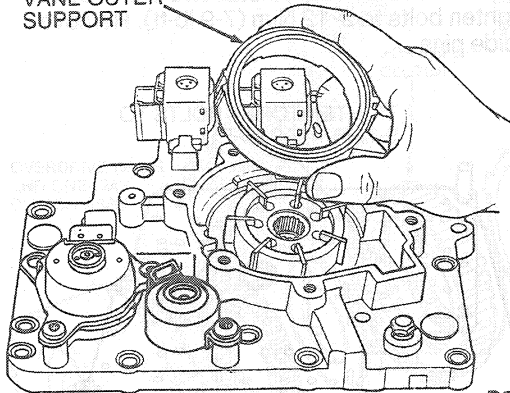

D8856-B

6. Install top vane positioning ring.

TOP VANE POSITIONING RING

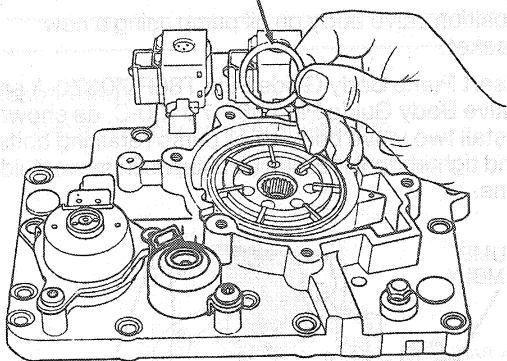

D8855-B

7. Install new side seal support.

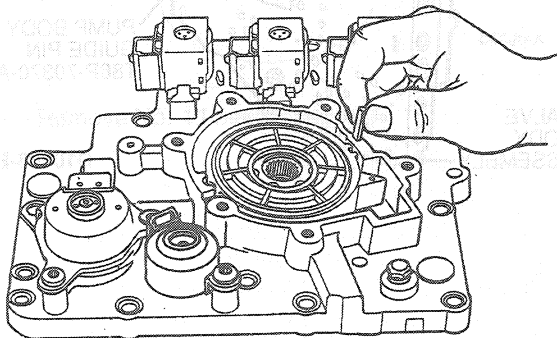

D8853-B

8. Install new side seal.

9. Install outer vane support retaining pin.

RETAINING PIN

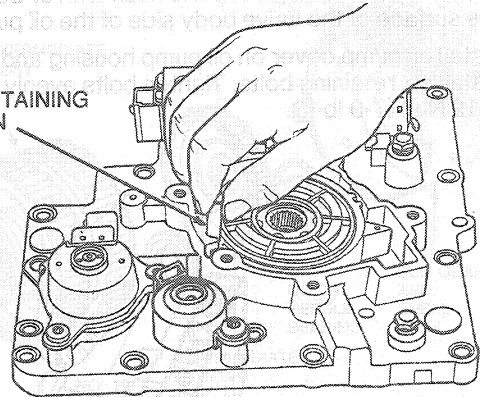

D8851-B

10. Install bore spring between case and tab on outer vane support.

COMPRESS SPRING DURING INSTALLATION INTO PUMP HOUSING

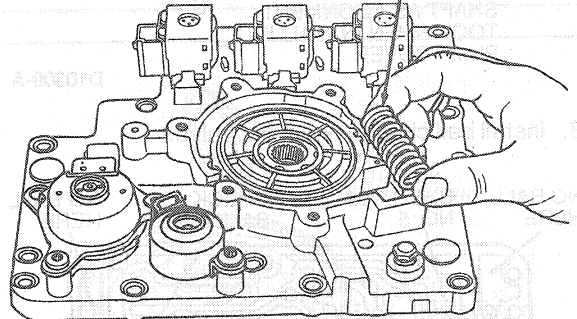

D8860-B

11. Install new O-ring in groove in outer vane support. Then, install metal O-ring retainer.

RUBBER O-RING

METAL O-RING RETAINER

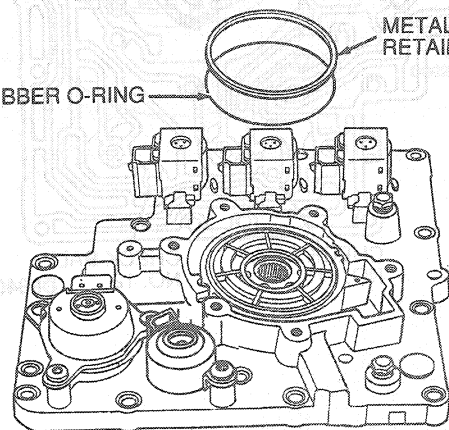

D8852-B

NOTE: Use the oil pump drive shaft to align the pump gears while installing the pump cover.