

## DISASSEMBLY AND ASSEMBLY (Continued)

8. Remove slotted end of bimetal from its pin. Position plate slotted ends onto rear and middle retaining pins. Install slotted end of bimetal under retaining collar.

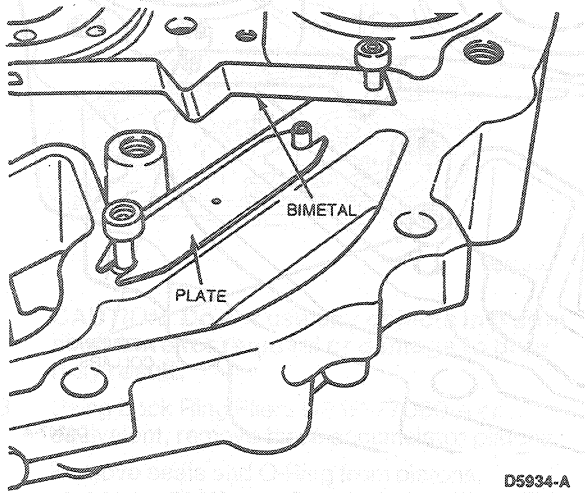

D5934-A

NOTE: Lube seals and O-ring with a light coating of petroleum jelly.

9. Install new seals and O-ring on accumulator pistons.

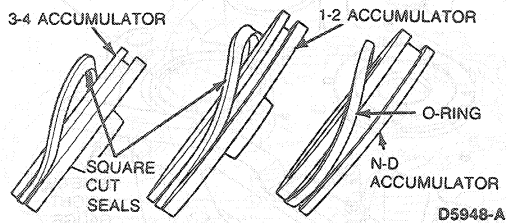

D5948-A

**CAUTION:** Do not allow pistons to cock in their bores. Seal and bore damage may result.

10. Install accumulator pistons into their proper cylinder.

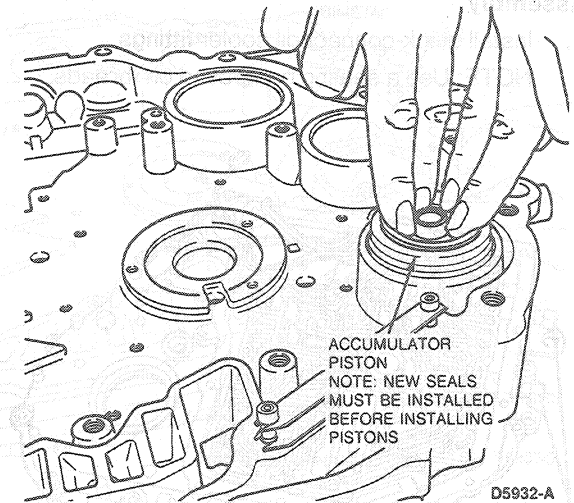

D5932-A

11. Install three accumulator piston shafts.

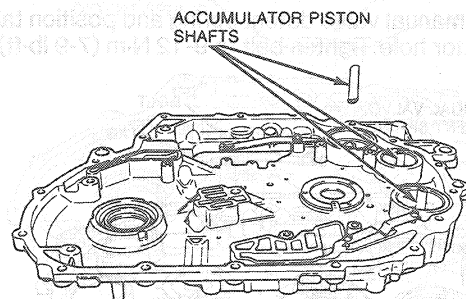

D5950-A

12. Install new O-ring on connector.  
13. Install new connector by pushing into bore from the outside until a "click" is heard.

## Oil Pump and Valve Body Assembly

## Disassembly and Assembly

## Tools Required:

- Valve Body Guide Pin Set T86P-70100-A
- Valve Body Guide Pin T86P-70100-B
- Valve Body Guide Pin T86P-70100-C
- Pump Body Guide Pins T86P-70370-A