

DISASSEMBLY AND ASSEMBLY (Continued)

Assembly

- 1. Install quick-connect oil cooler fittings.
NOTE: Use a sealing compound on threads.

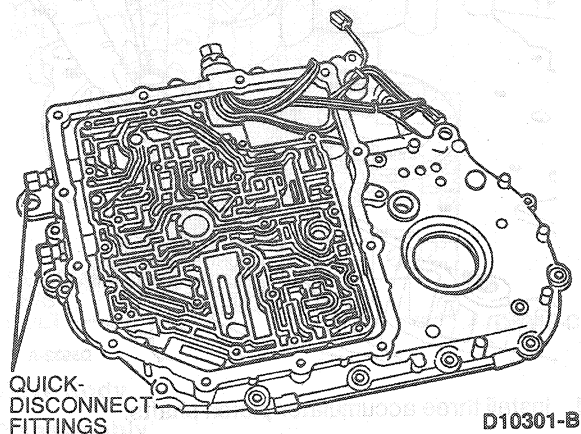

- 2. Install manual valve detent spring and position tab in locator hole. Tighten bolt to 9-12 N·m (7-9 lb-ft).

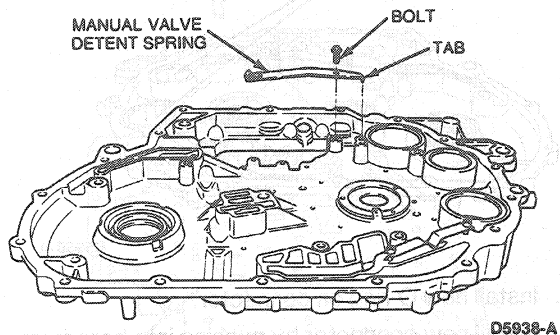

- 3. Start bimetal retaining pins in cover. Gently tap center pin to bottom of hole.

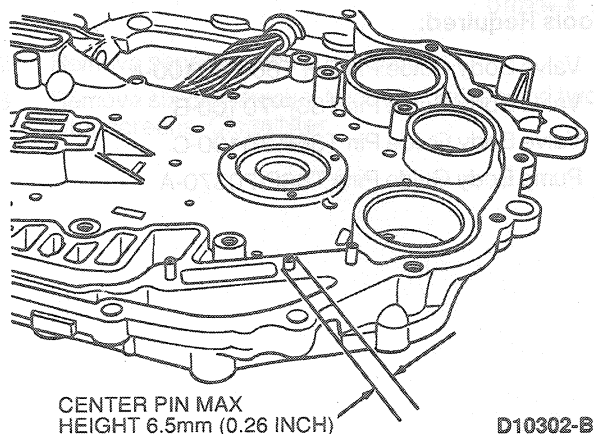

- 4. Place end of bimetal with hole over front retaining pin. Install bimetal retaining collars.

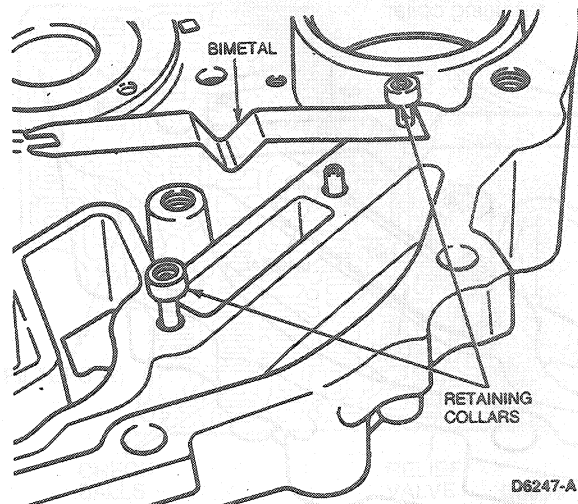

- 5. Place Bimetal Height Gauge T86P-70422-A against retaining pin and under bimetal.
- 6. Gently tap retaining collar onto pin until it seats against tool edge.

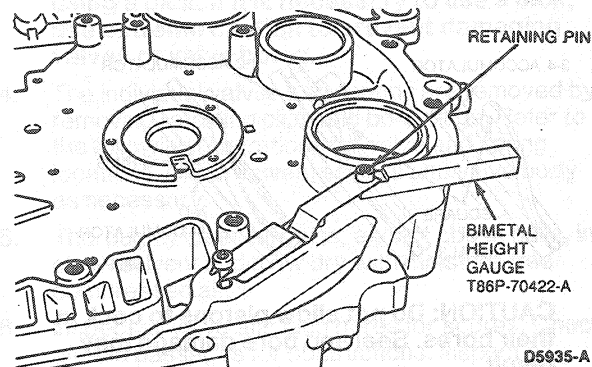

- 7. Engage slotted end of bimetal under rear retaining pin and retaining collar and then repeat Steps 5 and 6 for slotted end of bimetal.