

DISASSEMBLY AND ASSEMBLY (Continued)

60. Remove No. 18 thrust washer and No. 19 needle bearing.

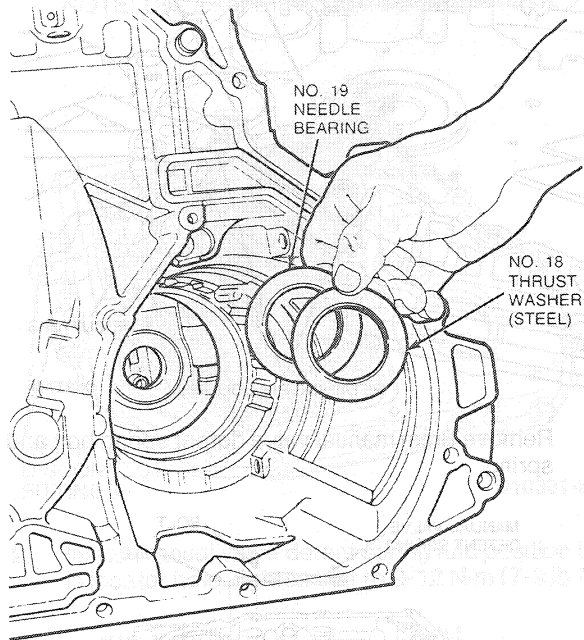

D5899-B

61. Remove final drive ring gear from case.

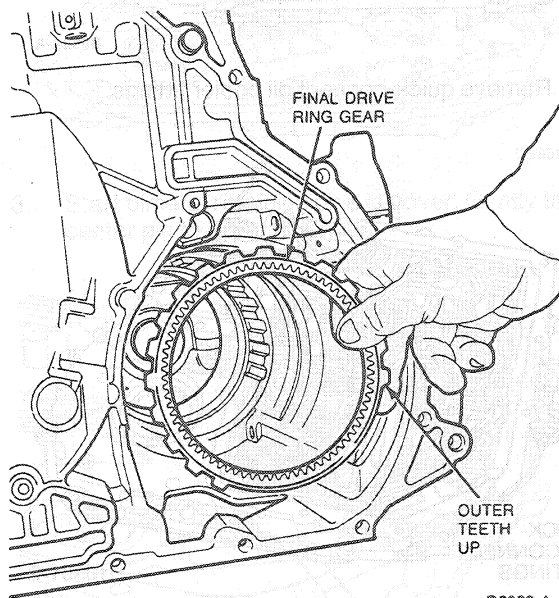

D6023-A

62. If case replacement is necessary, rotate case 180 degrees and remove six T-30 Torx® bolts attaching support to case.

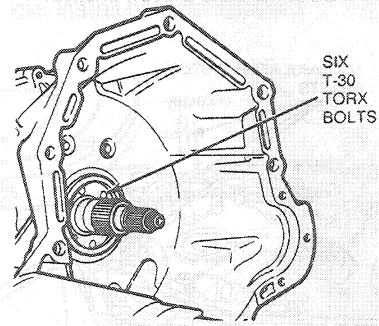

D6234-A

Subassemblies

Chain Cover

Tools Required:

- Locknut Pin Remover T78P-3504-N
- Lock Ring Pliers T81P-77060-A
- Bimetal Height Gauge T86P-70422-A

Disassembly

CAUTION: Do not pull on wiring. Pull on connector.

1. If wiring or chain cover replacement is necessary, compress tabs on both sides of connector from inside of chain cover. Remove connector and wiring from chain cover.

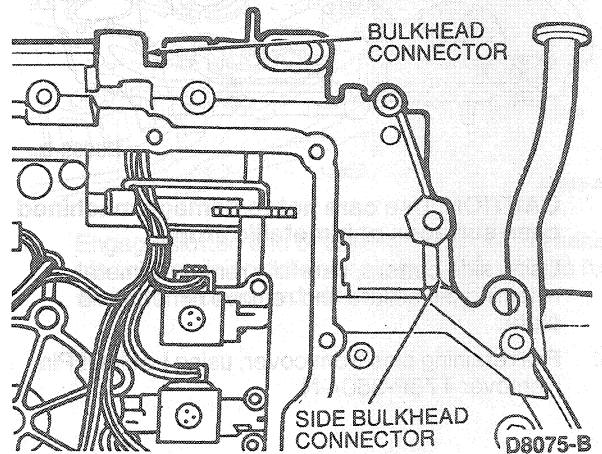

D8075-B