

**DISASSEMBLY AND ASSEMBLY (Continued)**

**SHO**

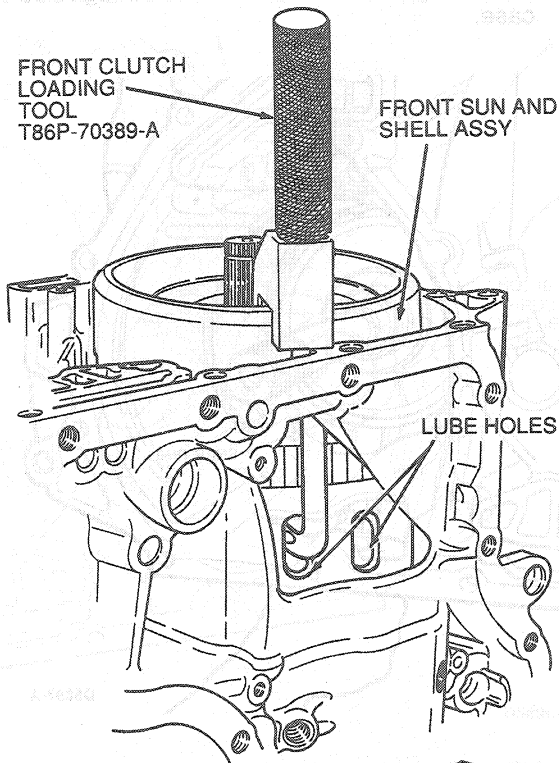

NOTE: MODIFY CLUTCH LOADING TOOL TO FIT LUBE HOLES BY REMOVING 0.50mm (0.02 INCH) OF MATERIAL OFF EACH SIDE OF TOOL.

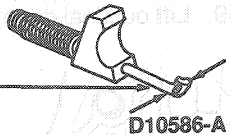

53. Loosen 19mm reverse clutch anchor pin nut and remove 6mm Allen head bolt.

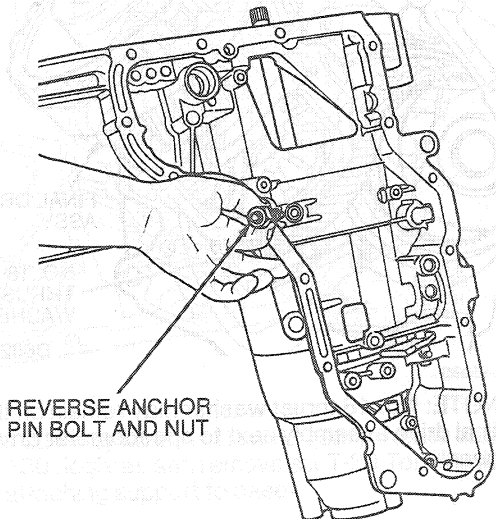

REVERSE ANCHOR PIN BOLT AND NUT

D5902-B

54. Locate hook portion of Front Clutch Loading Tool T86P-70389-A on inner diameter of reverse clutch cylinder. Grasp outer diameter of cylinder with fingertips and slide clutch assembly out of case.

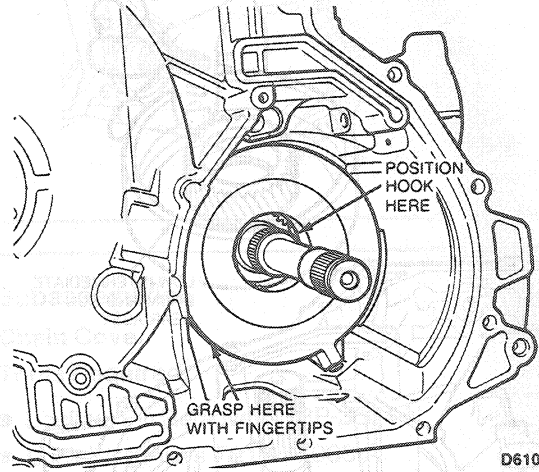

D6107-A

55. Holding the front planetary shaft, lift out both front and rear planetary assembly.

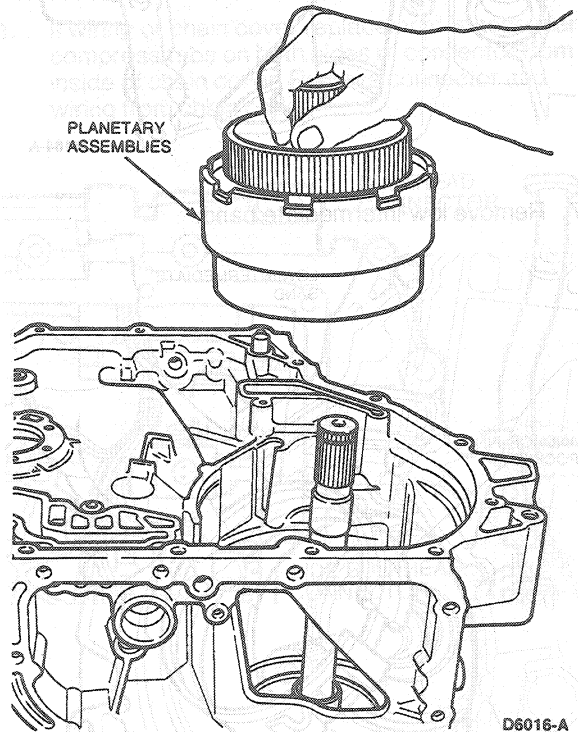

D6016-A