

**DISASSEMBLY AND ASSEMBLY (Continued)**

26. Remove 13 10mm, one 13mm, one 8mm bolt, and one 24mm mounting stud. Note length and location of bolts. Start at inside and work out.

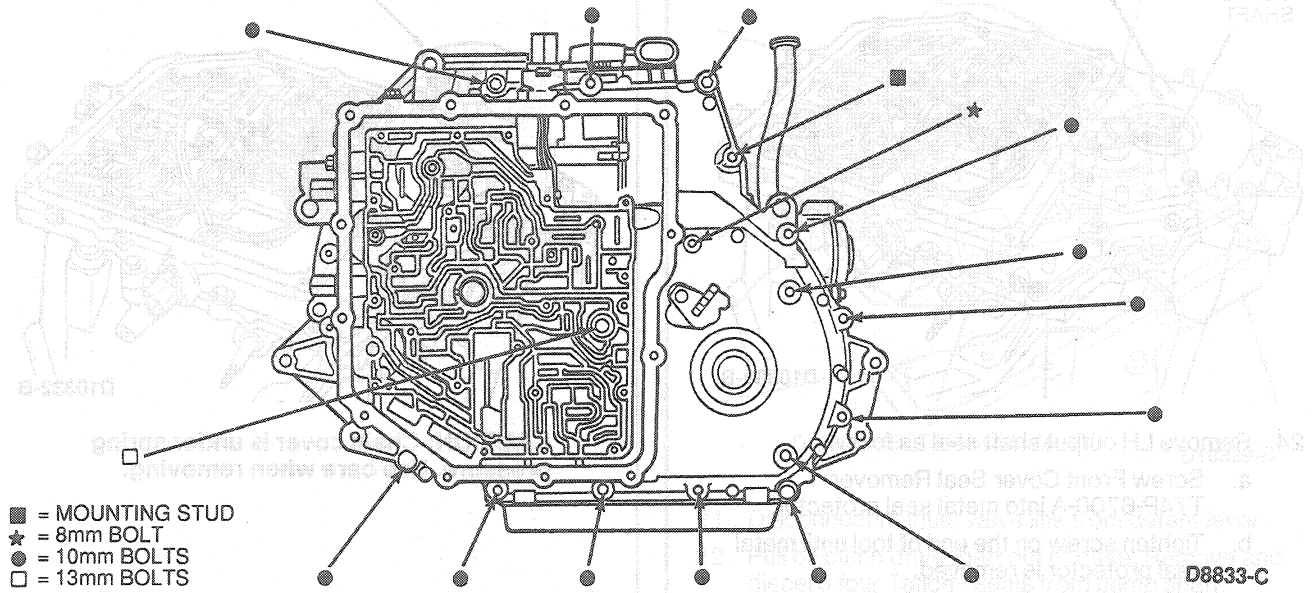

27. Remove chain cover and tag accumulator springs to be sure they are installed in their correct positions during assembly.

28. Remove and discard chain cover gasket.

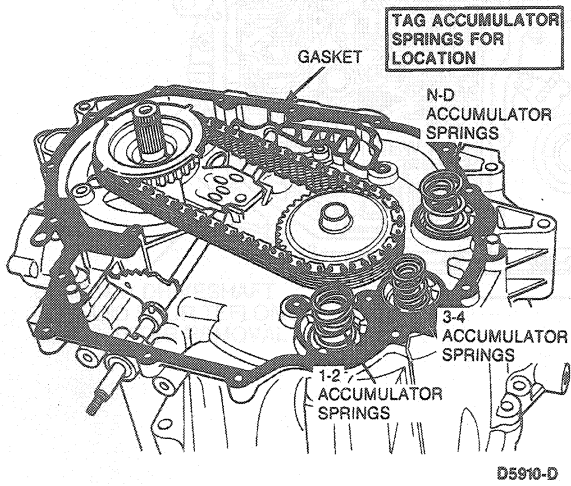

29. Remove No. 1 and No. 3 thrust washers from chain cover.

