

DISASSEMBLY AND ASSEMBLY (Continued)

- c. Tighten screw on end of tool until metal seal protector is removed.

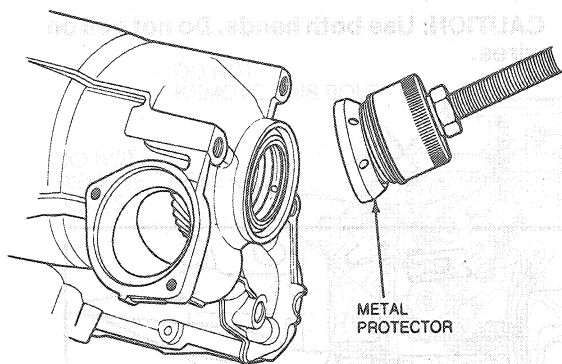

- d. Remove metal seal protector from tool, and install tool into seal.
- e. Tighten screw on the end of tool until seal is removed.

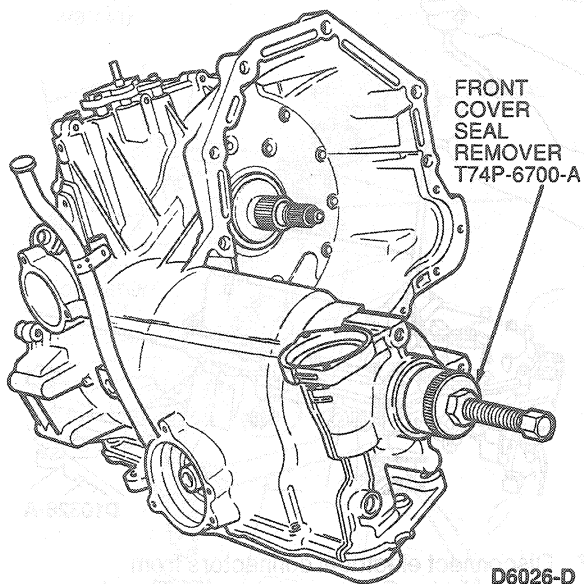
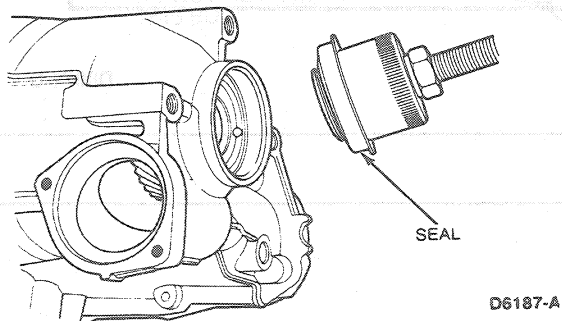

- 11. Remove two 8mm MLP sensor retaining bolts and remove switch.

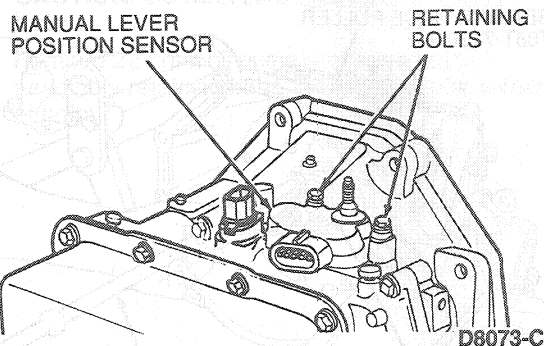

- 12. Remove one 8mm filler tube retaining bolt and pull tube from case.

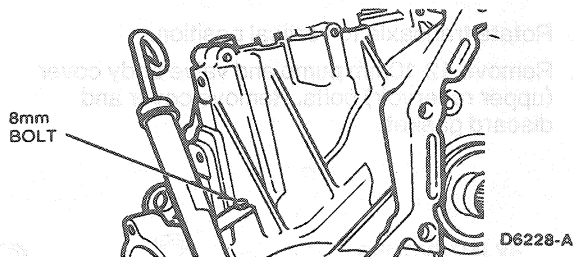

- 13. Remove five 10mm and four 8mm chain cover bolts from inside torque converter housing.

