

SECTION 07-03 Transaxle, Manual—MTX IV

SUBJECT	PAGE	SUBJECT	PAGE
CLEANING AND INSPECTION		MAJOR SERVICE OPERATIONS (Cont'd.)	
Bearing Cups.....	07-03-51	Differential Bearing Cups.....	07-03-61
Cone and Roller Assemblies.....	07-03-52	Differential Bearing Preload.....	07-03-58
Differential Case.....	07-03-51	Differential Seals.....	07-03-62
Flywheel.....	07-03-51	In-Vehicle Service.....	07-03-58
Gears.....	07-03-51	Input Cluster Shaft Bearings.....	07-03-52
Transaxle Case.....	07-03-50	Input Cluster Shaft Seal Assembly.....	07-03-52
DESCRIPTION	07-03-1	Mounting Brackets And Inner Boot.....	07-03-58
DIAGNOSIS		Shift Knob, Boot and Control Assembly.....	07-03-56
Transaxle Noise.....	07-03-11	Speedometer Driven Gear.....	07-03-55
DISASSEMBLY AND ASSEMBLY		Speedometer Driven Gear.....	07-03-55
Clutch Housing.....	07-03-39	OPERATION	
Fifth Gear Shaft Assembly.....	07-03-37	Power Flow.....	07-03-8
Fifth Gear Shift Control.....	07-03-44	Shift Controls.....	07-03-8
Main Shaft Assembly.....	07-03-31	REMOVAL AND INSTALLATION	
Main Shaft Assembly.....	07-03-34	Flywheel.....	07-03-30
Main Shift Control Shaft.....	07-03-42	Flywheel Ring Gear.....	07-03-30
Reverse Shift Relay Lever and Bracket.....	07-03-45	Transaxle.....	07-03-16
Selector Control Plate.....	07-03-45	SPECIAL SERVICE TOOLS	07-03-63
Synchronizer.....	07-03-33	SPECIFICATIONS	07-03-62
MAJOR SERVICE OPERATIONS		VEHICLE APPLICATION	07-03-1
Bearing Cups.....	07-03-53		

VEHICLE APPLICATION

Taurus with 3.0L SHO Engine.

DESCRIPTION

The MTX IV 5-Speed Manual Transaxle is similar in design and function to the MTX III 5-Speed Manual Transaxle. The major differences between the two transaxles are that the MTX-IV has wider gears, larger bearings, a four pinion aluminum differential assembly and a strengthened case.

The transaxle is a front-wheel drive powertrain unit. The transaxle and differential assemblies are housed in a single two-piece aluminum alloy case known as a transaxle. The transaxle is bolted to the back of the engine and is mounted transversely in the vehicle with the engine on the right and the transaxle on the left. Three separate gear shaft assemblies are used; the input cluster gear shaft, the main shaft for first to fourth gears and the fifth gear shaft. Helical cut gears are used in all forward ranges for quiet operation. All five forward gears are synchronized for ease of shifting.

The fifth gear range provides an effective overdrive ratio, which allows the engine to operate at reduced rpm providing reduced engine wear and improved fuel economy.

An automatic transmission-type fluid is used as a lubricant to ensure shifting ease under all driving conditions.

The 5-speed MTX IV manual transaxle assembly consists of a transmission and four-pinion differential, transversely mounted side-to-side in the vehicle. The transmission and differential are housed in a two-part lightweight aluminum alloy housing which is bolted to the engine assembly. The four-pinion differential is required due to the high output torque of the 3.0L SHO engine. The four pinion differential assembly is supported by two opposed tapered roller bearings and preload is maintained by means of a selected shim. The inboard constant velocity joints are positively connected with the differential side gears by means of splines and secured in the case with two circlips. The final drive gear is riveted to the two-piece aluminum differential case. Service replacement of the final drive gear or the two-piece aluminum differential case requires that the rivets be drilled and driven out of the case and service nuts and bolts be installed.

DESCRIPTION (Continued)

(Continued)

Item	Description
1	Mainshaft
2	Input Cluster Gear Shaft
3	4th Speed Gears
4	3rd Speed Gears
5	2nd Speed Gears
6	Reverse Gears
7	Reverse Idler Gear
8	1st Speed Gears
9	5th Speed Gear Shaft

Item	Description
10	5th Speed Gear
11	5th Gear Shaft Pinion Gear
12	Mainshaft Pinion Gear
13	Differential Oil Seals
14	CV Shafts
15	Differential Pinion Gears
16	Differential Side Gears
17	Final Drive Ring Gear
18	1st/2nd Synchronizer
19	3rd/4th Synchronizer
20	5th Synchronizer

(Continued)

MTX DISASSEMBLED VIEW

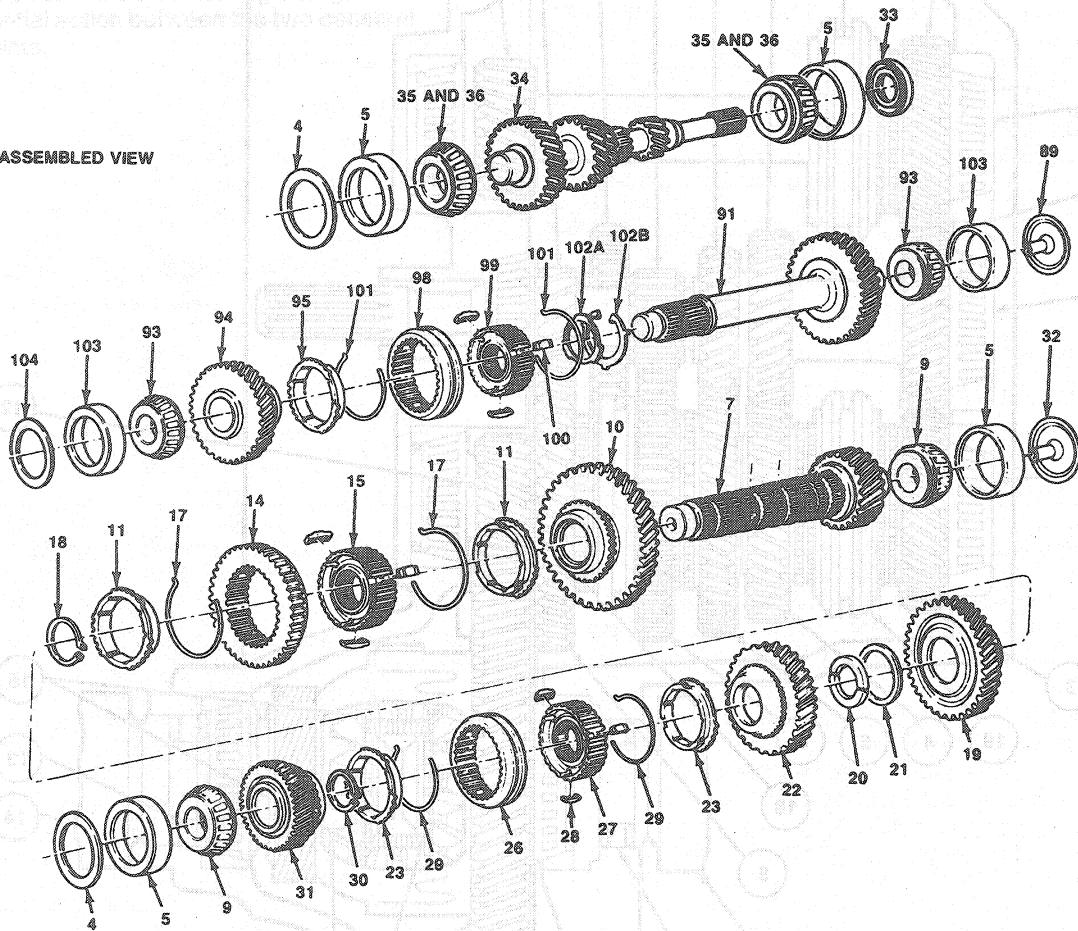

C4451-G

5-43143

DESCRIPTION (Continued)

MTX DISASSEMBLED VIEW — CONTINUED

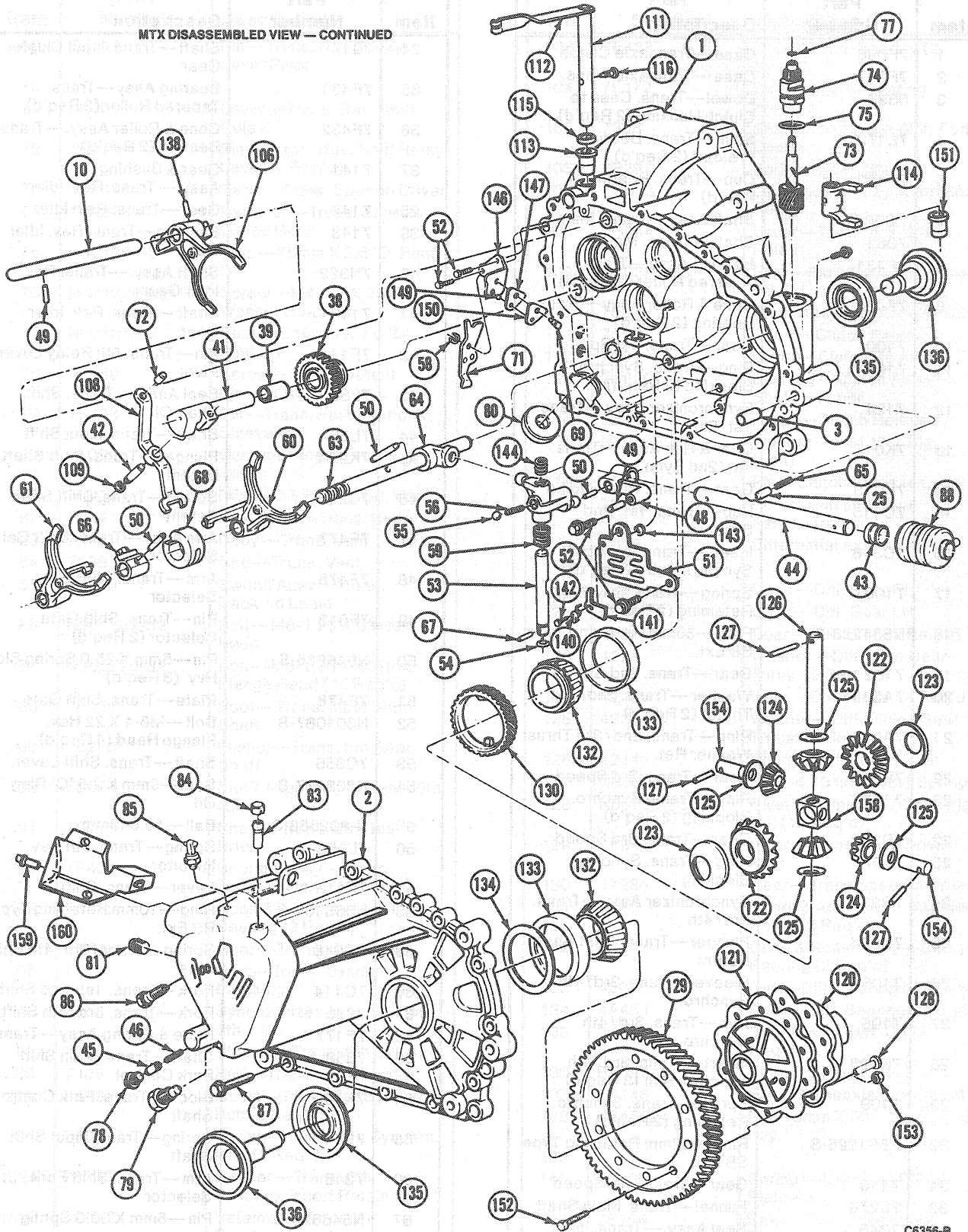

C6356-B

DESCRIPTION (Continued)

DESCRIPTION (Continued)

Item	Part Number	Description
1	7F096	Case—Transaxle Clutch
2	7F097	Case—Transaxle Trans.
3	6397	Dowel—Trans. Case to Clutch Housing (2 Req'd)
4	7L172	Shim—Trans. Bearing Preload (2 Req'd)
5	7F433	Cup—Trans. Bearing (4 Req'd)
6	7C094	Shaft Assy—Trans. Main
7	7061	Shaft—Trans. Main
8	7F431	Bearing Assy—Trans. Tapered Roller (2 Req'd)
9	7F432	Cone & Roller Assy—Trans. Bearing (2 Req'd)
10	7100	Gear—Trans. 1st Speed
11	7107	Ring—Trans. Synchro. Blocking (2 Req'd)
12	7124	Synchronizer Assy—Trans. 1st/2nd
13	7K012	Gear & Hub Assy—Trans. 1st/2nd Sync.
14	7K013	Gear—Trans. Rev. Sliding
15	7C115	Hub—Trans. 1st/2nd Synchro.
16	7C396	Insert—Trans. 1st/2nd Synchro. Hub (3 Req'd)
17	7109	Spring—Trans. Synchro. Retaining (2 Req'd)
18	N661228-S	Ring—35mm Retaining Type SB Ext.
19	7102	Gear—Trans. 2nd Speed
20	7A385	Washer—Trans. 2nd/3rd Thrust (2 Req'd)
21	7A046	Ring—Trans. 2nd/3rd Thrust Washer Ret.
22	7B340	Gear—Trans. 3rd Speed
23	7107	Ring—Trans. Synchro. Blocking (2 Req'd)
22	7B340	Gear—Trans. 3rd Speed
23	7107	Ring—Trans. Synchro. Blocking
24	7B280	Synchronizer Assy—Trans. 3rd/4th
25	7K204	Plunger—Trans. Shift Shaft Detent
26	7106	Sleeve—Trans. 3rd/4th Synchro.
27	7105	Hub—Trans. 3rd/4th Synchro.
28	7K198	Insert—Trans. 3rd/4th Synchro. Hub (3 Req'd)
29	7109	Spring—Trans. Synchro. Retaining (2 Req'd)
30	N661226-S	Ring—32mm Retaining Type SB Ext.
31	7110	Gear—Trans. 4th Speed
32	7L276	Funnel—Trans. Main Shaft
33	7048	Seal Assy.—Trans. Input Shaft Oil

(Continued)

Item	Part Number	Description
34	7017	Shaft—Trans. Input Cluster Gear
35	7F431	Bearing Assy—Trans. Tapered Roller (2 Req'd)
36	7F432	Cone & Roller Assy.—Trans. Bearing (2 Req'd)
37	7141	Gear & Bushing Assy.—Trans. Rev. Idler
38	7142	Gear—Trans. Rev. Idler
39	7143	Bushing—Trans. Rev. Idler Gear
40	7N322	Shaft Assy.—Trans. Rev. Idler Gear
41	7140	Shaft—Trans. Rev. Idler Gear
42	7F111	Pin—Trans. 5th Relay Lever Pivot
43	7288	Seal Assy.—Trans. Shift Shaft Oil
44	7L267	Shaft—Trans. Input Shift
45	7K204	Plunger—Trans. Shift Shaft Detent
46	7C288	Spring—Trans. Shift Shaft Detent
47	7F477	Arm Assy—Trans. Shift Gate Selector
48	7F478	Arm—Trans. Shift Gate Selector
49	7F013	Pin—Trans. Shift Gate Selector (2 Req'd)
50	N646635-S	Pin—5mm X 25.0 Spring Slot Hvy. (3 Req'd)
51	7F476	Plate—Trans. Shift Gate
52	N801087-S	Bolt—M6-1 X 22 Hex. Flange Head (4 Req'd)
53	7C355	Shaft—Trans. Shift Lever
54	N802277-S	Seal—9mm X 2.6 'O' Ring Oil
55	N-802568-S	Ball—10.319mm
56	7L058	Spring—Trans. 5th Rev. Inhibitor
57	7F116	Lever—Trans. Shift
58	N663109-S	Ring—10mm Retaining Type RB Ext.
59	7G046	Spring—Trans. 3rd/4th Shift Bias
60	7C114	Fork—Trans. 1st/2nd Shift
61	7230	Fork—Trans. 3rd/4th Shift
62	7F177	Plate & Spring Assy—Trans.
63	7358	Shaft—Trans. Main Shift Fork Control
64	7K105	Block—Trans. Fork Control Shaft
65	7234	Spring—Trans. Input Shift Shaft
66	7346	Arm—Trans. Shift Fork Selector
67	N646629-S	Pin—5mm X 30.0 Spring
68	7K201	Sleeve—Trans. Shift Fork Interlock

(Continued)

DESCRIPTION (Continued)

(Continued)

Item	Part Number	Description
69	7F111	Pin—Trans. Rev. Relay Lever Pivot
70		
71	7K002	Lever—Trans. Rev. Shift Relay
72	7K218	Pin—Trans. Rev. Shift Relay Lever (2 Req'd)
73	17271	Gear—Trans. Speedo Driven
74	17K288	Retainer—Trans. Speedo. Driven Gear
75	N801061-S	Seal—25mm X 2.6 'O' Ring Oil
76	N801034-S2	Screw—M4-0.7 X 25 Hex. Washer Head
77	N801370-S	Seal—5.16mm X 1.6 'O' Ring Oil
78	7F489	Screw—Trans. Detent Plunger Ret.
79	7F488	Pin—Trans. Fork Interlock Sleeve Ret.
80	7L027	Ceramic Magnet—Trans. Case
81	7N439	Plug—JIS PT 1/2 Sq. Hd.
82	7034	Vent Assy—Trans. Case
83	7035	Body—Trans. Vent
84	7036	Cap—Trans. Vent
85	15520	Switch Assy—Trans. Back-up Lamp
86	N801862-S2	Bolt—M8-1.25 X 33 Hex. Head
87	N605790-S2	Bolt—M8-1.25 X 40 Hex. Flange Head (15 Req'd)
88	7F110	Boot—Trans. Input Shift Shaft
89	7L276	Funnel—Trans. 5th Gear Shaft
90	7C094	Shaft Assembly—Trans. 5th Gear
91	7061	Shaft—Trans. 5th Gear Drive
92	7F431	Bearing Assy—Trans. Tapered Roller (2 Req'd)
93	7F432	Cone & Roller Assy—Trans. Bearing (2 Req'd)
94	7K316	Gear—Trans. 5th Speed
95	7107	Ring—Trans. Synchro. Blocking
96	7124	Synchronizer Assy.—Trans. 5th
98	7106	Sleeve—Trans. 5th Synchro.
99	7105	Hub—Trans. 5th Synchro.
100	7K198	Insert—Trans. 5th Synchro. Hub (3 Req'd)
101	7109	Spring—Trans. 5th Synchro. Ret. (2 Req'd)
102A	7L049	Spacer—Trans. 5th Synchro. Insert Retaining
102B	7G042	Retainer—Trans. 5th Synchro. Insert

(Continued)

Item	Part Number	Description
103	7F433	Cup—Trans. Bearing (2 Req'd)
104	7L172	Shim—Trans. Bearing Preload
105	7358	Shaft—Trans. 5th Shift Fork Control
106	7B297	Fork—Trans. 5th Shift
107	7G043	Lever Assy—Trans. 5th Shift Relay
108	7G044	Lever—Trans. 5th Shift Relay
109	N802832-S	Ring—8mm Retaining Type RB Ext.
110	7503	Shaft Assy—Clutch Release
111	7510	Shaft—Clutch Release
112	7591	Lever—Clutch Release
113	7N620	Bushing—Clutch Release Shaft—Upper
114	7541	Lever—Clutch Release
115	N803859-S	Washer—Flat 17.7 Dia. (Felt)
116	7565	Pin—Clutch Release Lever
117	7F465	Differential and Gear Assy—Transaxle
118	1026	Differential Assy.
119		
120	4205	Case—Diff. Gear RH
121	4206	Case—Diff. Gear LH
122	4236	Gear—Diff. Side (2 Req'd)
123	4228	Washer—Diff. Side Gear Thrust (2 Req'd)
124	4215	Gear—Diff. Pinion (4 Req'd)
125	4230	Washer—Diff. Pinion Gear Thrust (4 Req'd)
126	4211	Shaft—Diff. Pinion Gear
127	N800979-S	Pin—4.75mm X 38.1 Spring
128	N802940-S	Rivet—12mm X 37 Solid Flat Hd. (10 Req'd)
129	7F343	Gear—Trans. Final Drive Ring
130	17285	Gear—Trans Speedo. Drive
131	4220	Bearing Assy—Diff. Tapered Roller (2 Req'd)
132	4221	Cone & Roller Assy—Diff. Bearing (2 Req'd)
133	4222	Cup—Diff. Bearing (2 Req'd)
134	4A451	Shim—Diff. Bearing Preload
135	1177	Seal Assy—Diff. Oil (2 Req'd)
136	Reference	Shipping Plug (2 Req'd)
137	7B148	Tag—Transaxle Service I.D.
138	N646624-S	Pin—5mm X 20.0 Spring Slot Hvy.
139		
140	7E200	Spring—Trans. Shift Gate Plate Pawl
141	7E159	Pawl—Trans. Shift Gate Plate

(Continued)

DESCRIPTION (Continued)

Item	Part Number	Description
142	7E484	Pin—Trans. Rev. Lockout Pawl Pivot
143	N663103-S2	Ring—4mm Ret. Type RB Ext.
144	7B146	Spring—Trans. 5th / Rev. Kick Down
145	7D378	Bracket Assy—Rev. Shift Relay Lever Support
146	7D379	Bracket—Rev. Shift Relay Lever Support
147	7L128	Spring—Trans. Rev. Shift Relay Lever
148	7K423	Shaft Assy—Trans. 5th Shift Fork Control

(Continued)

Item	Part Number	Description
149	7217	Ball—8.731mm
150	7L128	Spring—Trans. Rev. Shift Relay Lever Ret. Sec.
151	7N620	Bushing—Clutch Release Shaft—Lower
152	N802393-S100	Bolt-Service Replacement (10 Req'd)
153	N802389-S2	Nut-Service Replacement (10 Req'd)
154	4419	Pinion Shaft
158	4420	Pinion Shaft Seat
159	N605800-S2	Bolt—Bracket Mounting
160	7F325	Bracket Assy—Energy

OPERATION

Power Flow

Engine torque is transferred from the clutch to the input cluster gear shaft. The four forward gears on the input cluster gear shaft are in constant mesh with a matching gear on the main shaft. The fourth gear on the input cluster gear shaft is simultaneously meshed with the fifth speed gear on the fifth gear shaft. These meshed gearsets provide the five available forward gear ratios.

Both the main shaft and the fifth gear shaft have a pinion gear, which is constantly engaged with the final drive ring gear on the differential assembly. If one of the gears (first through fourth) on the main shaft is selected, and that gear is locked to the shaft by its shifted synchronizer, then the input cluster shaft gear will drive the main shaft pinion gear; driving the differential final drive ring gear. If the fifth gear is selected the input cluster shaft fourth gear will drive the fifth gear shaft pinion gear; driving the differential final drive ring gear. At this time, the main shaft gears will rotate freely.

The gear ratios are as follows:

1st 3.21:1

2nd 2.09:1

3rd 1.37:1

4th 1.02:1

5th 0.75:1

Rev. 3.14:1

Final 3.74

The fifth gear range provides a ratio, in which, the input speed (rpm) from the engine is less than the transaxle output speed to the differential.

REVERSE is accomplished by moving an idler gear into mesh with the input cluster shaft gear and the reverse sliding gear on the main shaft. The reverse idler gear acts as an idler and reverses the direction of main shaft rotation.

In NEUTRAL, none of the gears on the main shaft or the fifth gear driveshaft are locked to their shafts. No torque from the engine to the input cluster gear shaft is transferred to the differential assembly and to the wheels through the halfshafts.

Shift Controls**External**

The manual shift mechanism is made up of the following components:

- Control Assembly
- Shift Rod
- Stabilizer Rod
- Gear Shift Lever
- Shift Boot Assembly
- Shift Knob

The external gearshift mechanism consists of a gearshift lever, transaxle shift rod, stabilizer rod and shift housing. The shift rod is attached to the shift shaft.

The shift housing provides a gear shift lever mounting and connection to the shift rod. The housing is bolted to the stabilizer, which is rubber mounted and fitted to the floorpan. On the transaxle end, the stabilizer rod is mounted through a rubber insulator to a boss on the clutch housing. The function of the stabilizer rod is to equalize the movement of the engine with the shift mechanism and prevent the engine movements from causing the gearshift to pull the transaxle out of gear. Rubber boots are provided for protection of the shafts and sound insulation. Adjustment of the external linkage is not necessary.

OPERATION (Continued)

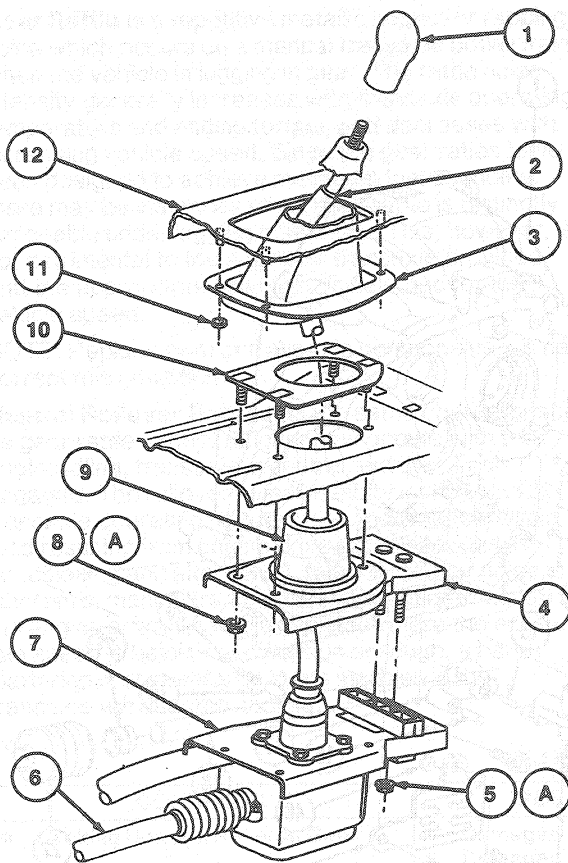

C9694-B

Item	Part Number	Description
1	7K327	Knob Assy
2	7210	Shift Lever
3	7B118	Boot
4	7L238	Lower Mounting Bracket
5A	N801555-S56	Nut (2 Req'd)
6	7202	Shift Rod

(Continued)

Item	Part Number	Description
7	7400	Control Assy
8A	N801555-S56	Nut (4 Req'd)
9	—	Part of Lower Mounting Bracket
10	7L239	Inner Mounting Bracket
11	45043-S2	Spring Nut (4 Req'd)
12	—	Console Body
A		Tighten to 13-17 N·m (115-150 Lb·In)

Internal

Internally, the gear shift mechanism begins with the input shift shaft, which is connected to the external linkage.

Attached to the input shift gate is the shift gate selector arm. The selector arm and its associated selector plate act together to transmit the inward, outward and rotational movements of the input shift shaft to the internal shift lever. The shift lever in turn, transmits these motions to the main shift control shaft, to which the first / second and third / fourth shift forks are attached.

The fifth shift relay lever is connected to a main shift control shaft member and transmits motion to the fifth gear control shaft, to which the fifth shift fork is attached. Movement in one direction actuates fifth gear. In the other direction the reverse shift relay lever is actuated, engaging the reverse idler gear with the input cluster and main shaft reverse sliding gear.

An interlock is provided on the main shift control shaft. The interlock allows the shifting of only one synchronizer at a time. This prevents the engagement of the transaxle in two gears at the same time.

The reverse idler gear is shifted into position when a pin on the fifth gear control shaft engages the reverse relay lever. The pin moves the reverse relay lever which moves the gear on the reverse idler shaft into engagement with the input cluster shaft and main shaft reverse sliding gear.

OPERATION (Continued)

The backup lamp switch is actuated by movement of the fifth gear control shaft.

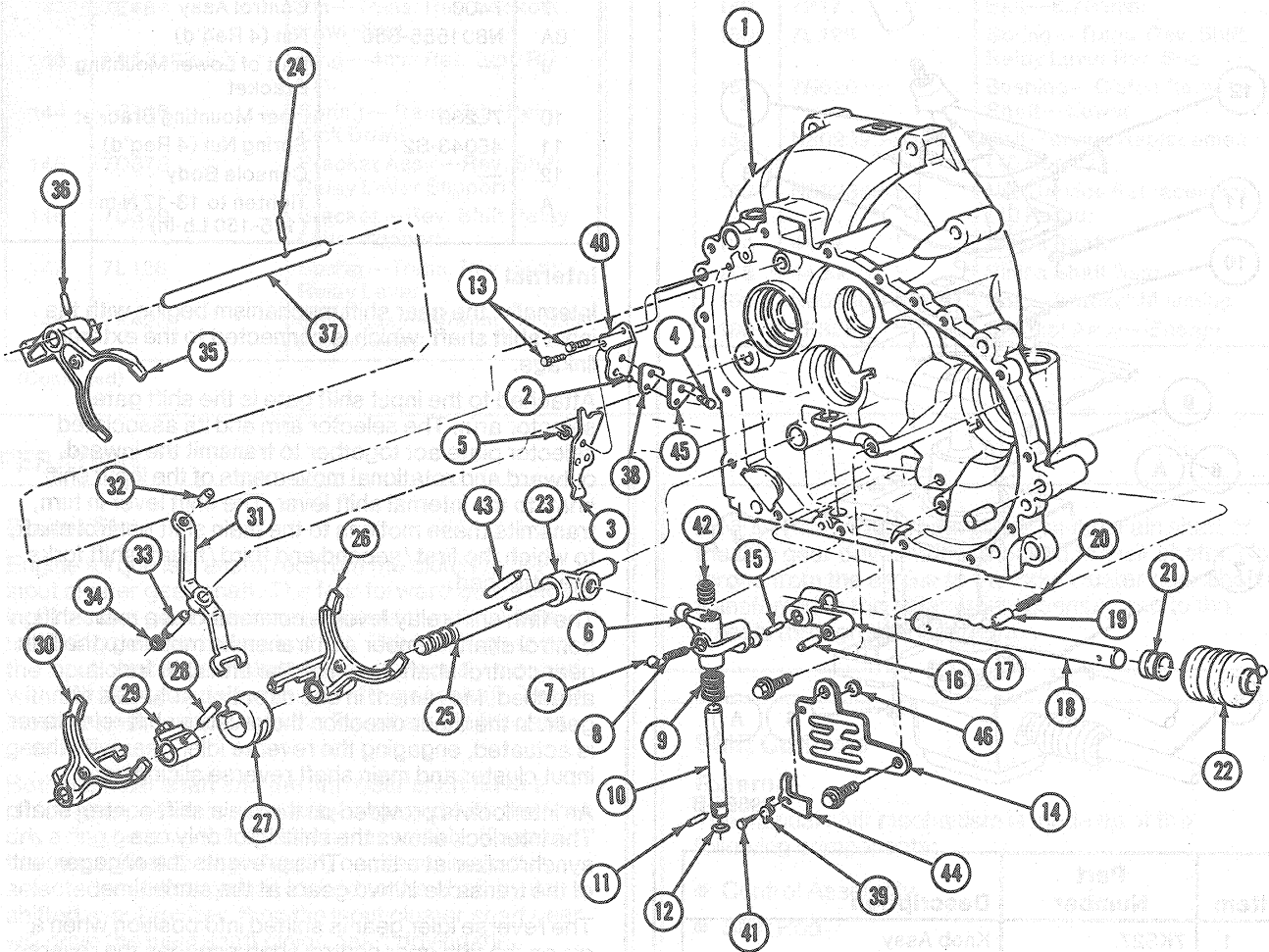

ITEM	DESCRIPTION
1.	CASE—CLUTCH HOUSING
2.	BALL
3.	LEVER—REVERSE RELAY
4.	PIN—REVERSE RELAY LEVER PIVOT
5.	RING—EXTERNAL RETAINING
6.	LEVER—SHIFT
7.	BALL—10.319mm
8.	SPRING—5TH/REVERSE INHIBITOR
9.	SPRING—3RD/4TH SHIFT BIAS
10.	SHAFT—SHIFT LEVER
11.	PIN—SHIFT LEVER
12.	SEAL—SHIFT LEVER SHAFT
13.	BOLTS—SHIFT GATE ATTACHING
14.	PLATE—SHIFT GATE
15.	ROLL PIN—SELECTOR ARM
16.	PIN—SHIFT GATE SELECTOR
17.	ARM—SHIFT GATE SELECTOR
18.	SHAFT—INPUT SHIFT
19.	PLUNGER—SHIFT SHAFT DETENT
20.	SPRING—SHIFT SHAFT DETENT
21.	SEAL ASSEMBLY—SHIFT SHAFT OIL
22.	BOOT—SHIFT SHAFT
23.	BLOCK—TRANS INPUT FORK CONTROL SHAFT
24.	PIN—SHIFT GATE SELECTOR

ITEM	DESCRIPTION
25.	SHAFT—MAIN SHIFT FORK CONTROL
26.	FORK—1ST/2ND
27.	SLEEVE—FORK INTERLOCK
28.	PIN—SPRING
29.	ARM—FORK SELECTOR
30.	FORK—3RD/4TH
31.	LEVER—5TH SHIFT RELAY
32.	PIN—REVERSE SHIFT RELAY LEVER
33.	PIN—5TH RELAY LEVER PIVOT
34.	RING—EXTERNAL RETAINING
35.	FORK—5TH
36.	SPRING PIN—5TH RETAINING
37.	SHAFT—5TH FORK CONTROL
38.	SPRING—TRANS REVERSE SHIFT RELAY LEVER
39.	SPRING—SHIFT GATE PAWL
40.	BRACKET—REVERSE SHIFT RELAY LEVER SUPPORT
41.	PIN—REVERSE LOCKOUT PAWL PIVOT
42.	SPRING—5TH/REVERSE KICKDOWN
43.	PIN—REVERSE RELAY LEVER ACTUATING
44.	PAWL—SHIFT GATE PLATE
45.	SPRING—TRANS REVERSE SHIFT RELAY LEVER RET. SEC.
46.	C-CLIP

C6359-A

DIAGNOSIS (Continued)

DIAGNOSIS (Continued)

Transaxle Noise

Gear Rattle is a repetitive metallic impact or rapping noise which occurs on a manual transaxle powertrain when the vehicle is lugging in gear. The rattle noise intensity generally increases with transaxle operating temperature and engine torque, and decreases with increasing vehicle speed. Since the gear ratios have been designed to achieve maximum fuel economy, there may be instances when gear rattle is distinctly noticeable under lugging conditions. This, however, is not detrimental to the engine or transaxle provided that the appropriate gear ratio is selected for the vehicle speed.

NOTE: Replacement of transaxle components will not correct this condition.

Neutral Rollover Rattle has the same characteristics as gear rattle except rollover now occurs with the engine idling, transaxle in neutral and the clutch engaged. The rollover noise intensity increases with transaxle operating temperature and engine torque load resulting from engine driven accessories (air conditioning and alternator). Neutral rollover noise is inherent in manual transaxles and is not detrimental to the engine or transaxle. In vehicles where the engine idle speed is below specification or rough, a harsh clattering noise similar to loose marbles in the transaxle will become audible.

Neutral Rollover Noise caused by engine torsional vibrations, and clutch release bearing noise are sometimes mistaken for bearing noise. Neutral rollover noise will disappear when the transaxle is engaged in gear. Due to a constant running clutch release bearing (used for the self-adjusting clutch mechanism) noise caused by a worn or damaged clutch release bearing will be noticeable with the clutch engaged or disengaged. Release bearing noise can be checked by removing the clutch release cable and sliding the clutch release bearing away from contact with the pressure plate (by movement of the clutch release arm) if the noise is eliminated, then the clutch release bearing is worn or damaged. When concerns of this nature are encountered, it will be necessary to check the vehicle to determine if bearing noise exists. Transaxle service will not eliminate neutral rollover noise or clutch release bearing noise.

TRANSAXLE DIAGNOSIS

CONDITION	POSSIBLE SOURCE	ACTION
<ul style="list-style-type: none"> Clicking Noise in Reverse Gear 	<ul style="list-style-type: none"> Damaged or rough gears. Damaged linkage preventing complete gear travel. 	<ul style="list-style-type: none"> Replace damaged gears. Check for damaged or misaligned shift linkage or other causes of shift linkage travel restrictions.
<ul style="list-style-type: none"> Gear Clash into Reverse 	<ul style="list-style-type: none"> Owner not familiar with manual transaxle shift techniques. Damaged linkage preventing complete gear travel. 	<ul style="list-style-type: none"> Instruct customer to refer to Owner Guide on proper shifting and the time-lapse required before a shift into reverse. Check for damaged or misaligned shift linkage or other causes of shift linkage bind.
<ul style="list-style-type: none"> Gears Clash When Shifting From One Forward Gear to Another 	<ul style="list-style-type: none"> Improper clutch disengagement. Clutch disc installed improperly with damper springs toward flywheel. Worn or damaged shift forks, synchro-teeth (usually high mileage phenomenon). 	<ul style="list-style-type: none"> Refer to Section 08-01. Refer to Section 08-01. Check for damage, and service or replace as required.
<ul style="list-style-type: none"> Leaks 	<ul style="list-style-type: none"> False report. (Do not assume that lube on lower case surfaces is from gasket material leakage or seals.) Slight mist from vent. Other components leaking. Excessive amount of lubrication on transaxle — wrong type. Worn or damaged internal components 	<ul style="list-style-type: none"> Remove all traces of lube on exposed transaxle surfaces. Operate transaxle and inspect for new leakage. Normal condition that does not require service. If dripping, check lubricant level. Identify leaking fluid at engine, power steering, or transaxle. Check lube level and type. Fill to bottom of filler plug opening. Remove transaxle clutch housing lower dust cover and inspect for lube inside housing. Inspect for leaks at the shift lever shaft seal, differential seals and input shift shaft seal. Service as required.

DIAGNOSIS (Continued)

TRANSAXLE DIAGNOSIS (Continued)

CONDITION	POSSIBLE SOURCE	ACTION
<ul style="list-style-type: none"> Locked in One Gear — It Cannot Be Shifted Out of That Gear 	<ul style="list-style-type: none"> Damaged external shift mechanism. Internal shift components worn or damaged. Synchronizer damaged by burrs which prevent sliding action. 	<ul style="list-style-type: none"> Check external shift mechanism for damage. Service or replace as required. Disconnect external shift mechanism and verify problem by trying to shift input shift rail. Remove transaxle. Inspect the problem gear, shift rails and fork and synchronizer assemblies for wear or damage, service or replace as required. Replace synchronizer assembly.
<ul style="list-style-type: none"> Noise in Neutral 	<ul style="list-style-type: none"> Neutral rollover rattle. 	<ul style="list-style-type: none"> Refer to Neutral Rollover Rattle.
<ul style="list-style-type: none"> Noisy in Forward Gears 	<ul style="list-style-type: none"> Low lubricant level. Contact between engine / transaxle and chassis. Transaxle to engine block bolts loose. Worn or damaged input / output bearings. Worn or damaged gear teeth (usually high mileage phenomenon). Gear rattle. 	<ul style="list-style-type: none"> Fill to bottom of filler plug opening with Synthetic MERCON® Multi-Purpose Automatic Transmission Fluid E6AZ-19582-B (ESR-M2C 163-A2) or equivalent. Check for contact or for broken engine motor mounts. Tighten to 46-63 N-m (34-46 Lb-Ft). Remove transaxle. Inspect bearings and gear teeth for wear or damage. Replace parts as required. Refer to Gear Rattle.
<ul style="list-style-type: none"> Shifts Hard 	<ul style="list-style-type: none"> Incorrect lubricant. Sticking blocker ring. External shift mechanism binding. Improper clutch disengagement. Clutch disc installed improperly with damper springs toward flywheel. Internal damage to synchronizers or shift mechanism. 	<ul style="list-style-type: none"> Verify that MERCON® Multi-Purpose Automatic Transmission Fluid E6AZ-19582-B (ESR-M2C 163-AZ) or equivalent is present. Do not use gear lube or hypoid type lubricants. Check for proper installation of external shift mechanism. Refer to Section 08-01. Refer to 08-01. Check for damage to internal components.
<ul style="list-style-type: none"> Walks Out of Gear 	<ul style="list-style-type: none"> Damaged linkage preventing complete travel into gear. Floor shift boot stiff or improperly installed boot. Floor shift interference between shift handle and console. Broken / loose engine mounts. Worn or damaged internal components. 	<ul style="list-style-type: none"> Check for damaged shift mechanism. Verify jumpout with boot removed, replace boot if necessary. Adjust console to eliminate interference. Check for broken or loose engine mounts and service as required. Check shift forks, shift rails and shift rail detent system for wear or damage, synchronizer sliding sleeve and gear clutching teeth for wear or damage. Service or replace as required.

DIAGNOSIS (Continued)

TRANSAXLE DIAGNOSIS (Continued)

CONDITION	POSSIBLE SOURCE	ACTION
<ul style="list-style-type: none"> ● Will Not Shift Into One Gear —All Other Gears OK 	<ul style="list-style-type: none"> ● Damaged external shift mechanism. ● Floor shift. Interference between shift handle and console or floor cut out. ● Restricted travel of internal shift components. 	<ul style="list-style-type: none"> ● Check for damaged shift mechanism. Service or replace as necessary. ● Adjust console or cut out floor pan to eliminate interference. ● Disconnect external shift mechanism and shift the input shift rail through the gears to verify problem. Remove transaxle. Inspect fork system, synchronizer system and gear clutch teeth for restricted travel. Service or replace as required.
<ul style="list-style-type: none"> ● Will Not Shift Into Reverse <p>NOTE: The shift gate plate pawl prevents fifth /reverse shifts.</p>	<ul style="list-style-type: none"> ● Normal blackout due to position of non-synchronized reverse gear components. (Approximately 10 percent occurrence of normal reverse shifting.) ● Damaged external shift mechanism. ● Worn or damaged internal components. 	<ul style="list-style-type: none"> ● This condition is normal to all transaxles and requires only a double clutch procedure to successfully engage reverse. ● Check for damaged external shift mechanism. Remove shift mechanism at input shift rail and try shifting into REVERSE at the rail. ● Remove transaxle. Check for damaged reverse gear train or shaft components, misaligned reverse relay lever, shift rail and fork system. Check the gear clutching teeth and synchronizer system for restricted travel or damage. Service or replace as required.

SHIFT LINKAGE

CONDITION	POSSIBLE SOURCE	ACTION
<ul style="list-style-type: none"> ● Binding, Sticking Shift Feel—Difficult to Find or Engage Gears, High Shift Efforts 	<ul style="list-style-type: none"> ● Worn, damaged, missing bushings in shift rod U-joint. ● Bent shift rod, U-joint or multi-piece bracket. ● Bent or damaged stabilizer. ● Worn, missing stabilizer bushing. ● Nuts holding rear mount to lower mounting bracket missing or loose. ● Bolt holding stabilizer bar to transaxle case missing or loose. ● Nuts holding inner mounting bracket to lower mounting bracket missing or loose. ● Bolt, nut and clamp washers loose at shift rod to transaxle connection. ● Plastic control housing on shift lever cracked or damaged. ● Plastic pivot housing on shift lever damaged, cracked. ● Shift lever pivot balls worn or loose. ● Rear mount damaged or worn. ● Shift lever loose on support assembly. ● Shift lever pivot balls worn, loose or broken. ● Shift rod sealing boot torn. 	<ul style="list-style-type: none"> ● Replace shift rod. ● Replace shift rod. ● Replace support assembly. ● Replace stabilizer bushing. ● Tighten or replace nuts. ● Tighten or replace bolt. ● Tighten or replace nuts. ● Tighten or replace bolt, nut and clamp washers. ● Replace plastic control housing. ● Replace shift lever. ● Replace shift lever. ● Replace rear mount assembly. ● Tighten or replace self-tapping screws. ● Replace shift lever assembly. ● Replace shift rod assembly.

DIAGNOSIS (Continued)

(Continued)

SHIFT LINKAGE (Continued)

CONDITION	POSSIBLE SOURCE	ACTION
<ul style="list-style-type: none"> Excessive Noise, Rattles, Buzz or Tizz 	<ul style="list-style-type: none"> Worn, damaged, missing bushings in shift rod U-joint. Worn pivot balls on shift lever. Loose bolt, nut and clamp washers at shift rod to transaxle connection. Loose shift lever assembly. Loose control housing. Loose control assembly. Loose shift knob causes tizz. Mounting insulators torn. Inner shift boot torn, split. Stabilizer bar bushing worn or split. Pivot balls on shift lever chipped, cracked. Crimp on shift lever improperly placed allows loose pivot ball in pivot housing. 	<ul style="list-style-type: none"> Replace shift rod assembly. Replace shift lever assembly. Tighten or replace bolt, nut and clamp washers. Tighten or replace self-tapping screws. Tighten self-tapping screws attaching housing to stabilizer assembly. Tighten or replace nuts holding control assembly to bracket. Thread knob further onto shift lever. If still loose, replace knob assembly. Replace support assembly. Replace inner sealing boot. Replace stabilizer bushing. Replace shift lever assembly. Replace shift lever.
<ul style="list-style-type: none"> Shifter is Inoperative—Cannot Shift Gears 	<ul style="list-style-type: none"> Bolt, nut and clamp washers loose at clamp to transaxle connection. Shifter attachment to body weld bolts loose. Nuts holding rear mount to lower mounting bracket missing or loose. Nuts holding rear mounting bracket to lower mounting bracket missing or loose. Shift rod damaged or bent. Stabilizer bar is bent. Rear mount damaged or worn. Crimp holding pivot ball tight in pivot housing inadequate. 	<ul style="list-style-type: none"> Tighten or replace bolt, nut and clamp washers. Replace or tighten bolts on body J-nuts. Tighten or replace nuts. Tighten or replace nuts. Replace shift rod. Replace support assembly. Replace mount assembly. Replace shift lever assembly.
<ul style="list-style-type: none"> Shift Lever Feels Sloppy or Loose 	<ul style="list-style-type: none"> Nuts holding rear mount to lower mounting bracket missing or loose. Nuts holding inner mounting bracket to lower mounting bracket missing or loose. Bolt holding stabilizer bar to transaxle case missing or loose. Bolt, nut and clamp washers loose at clamp to transaxle connection. Stabilizer bar damaged. Plastic control housing cracked or damaged. Rear mount damaged or worn. Shift lever retaining screw loose or missing. Shift lever pivot balls worn or loose. Shift knob is loose on shift lever. 	<ul style="list-style-type: none"> Tighten or replace nuts. Tighten or replace nuts. Tighten or replace bolt. Tighten or replace bolt, nut and clamp washers. Replace control assembly. Replace plastic control housing. Replace rear mount. Tighten or replace shift lever retaining screws. Replace shift lever assembly. Thread knob further onto shift lever. If still loose, replace knob assembly.

DIAGNOSIS (Continued)

BEARING DIAGNOSIS

CONSIDER THE FOLLOWING FACTORS WHEN DIAGNOSING BEARING CONDITION:

1. GENERAL CONDITION OF ALL PARTS DURING DISASSEMBLY AND INSPECTION.
2. CLASSIFY THE PROBLEM WITH THE AID OF THE ILLUSTRATION.
3. DETERMINE THE CAUSE.
4. MAKE ALL SERVICES FOLLOWING RECOMMENDED PROCEDURES.

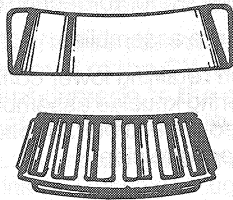

GOOD BEARING

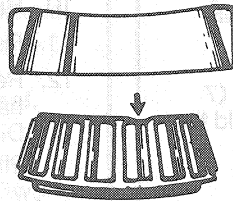

BENT CAGE

CAGE DAMAGE DUE TO IMPROPER HANDLING OR TOOL USAGE.
REPLACE BEARING

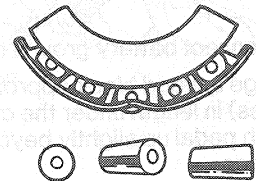

BENT CAGE

CAGE DAMAGE DUE TO IMPROPER HANDLING OR TOOL USAGE.
REPLACE BEARING.

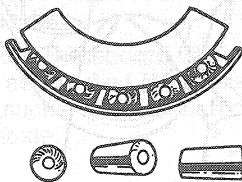

GALLING

METAL SMEARS ON ROLLER ENDS DUE TO OVERHEAT, LUBRICANT PROBLEM OR OVERLOAD.
REPLACE BEARING — CHECK SEALS AND CHECK FOR PROPER LUBRICATION.

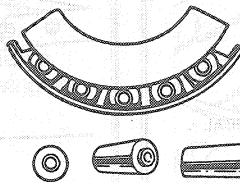

CRACKED INNER RACE

RACE CRACKED DUE TO IMPROPER FIT, COCKING, OR POOR BEARING SEATS.

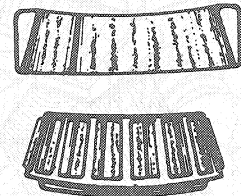

ETCHING

BEARING SURFACES APPEAR GRAY OR GRAYISH BLACK IN COLOR WITH RELATED ETCHING AWAY OF MATERIAL USUALLY AT ROLLER SPACING.
REPLACE BEARINGS — CHECK SEALS AND CHECK FOR PROPER LUBRICATION.

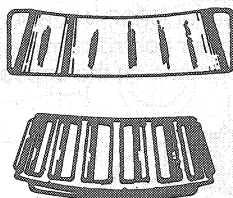

BRINELLING

SURFACE INDENTATIONS IN RACEWAY CAUSED BY ROLLERS EITHER UNDER IMPACT LOADING OR VIBRATION WHILE THE BEARING IS NOT ROTATING.
REPLACE BEARING IF ROUGH OR NOISY.

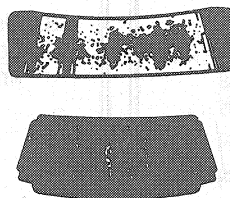

HEAT DISCOLORATION

HEAT DISCOLORATION IS DARK BLUE RESULTING FROM OVERLOAD OR NO LUBRICANT (YELLOW OR BROWN COLOR IS NORMAL).
EXCESSIVE HEAT CAN CAUSE SOFTENING OF RACES OR ROLLERS.
TO CHECK FOR LOSS OF TEMPER ON RACES OR ROLLERS A SIMPLE FILE TEST MAY BE MADE. A FILE DRAWN OVER A TEMPERED PART WILL GRAB AND CUT METAL, WHEREAS, A FILE DRAWN OVER A HARD PART WILL GLIDE READILY WITH NO METAL CUTTING.
REPLACE BEARINGS IF OVER HEATING DAMAGE IS INDICATED. CHECK SEALS AND OTHER PARTS.

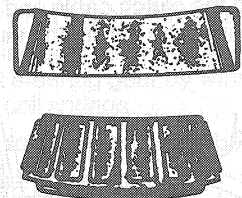

FATIGUE SPALLING

FLAKING OF SURFACE METAL RESULTING FROM FATIGUE.
REPLACE BEARING — CLEAN ALL RELATED PARTS.

C4074-C

REMOVAL AND INSTALLATION

Transaxle

Tools Required:

- Transaxle Plugs T81P-1177-B
- Differential Rotator T81P-4026-A
- Halfshaft Remover D83P-4026-A
- Rotunda Hi-Lift Jack 014-00210
- Rotunda Manual Transaxle Adapter 014-00225
- Rotunda Engine Support Bar 014-00750

Removal

1. Disconnect battery ground cable.
2. Wedge a wood block approximately 188mm (7 inches) in length under the clutch pedal to hold the clutch pedal up slightly beyond its normal position.

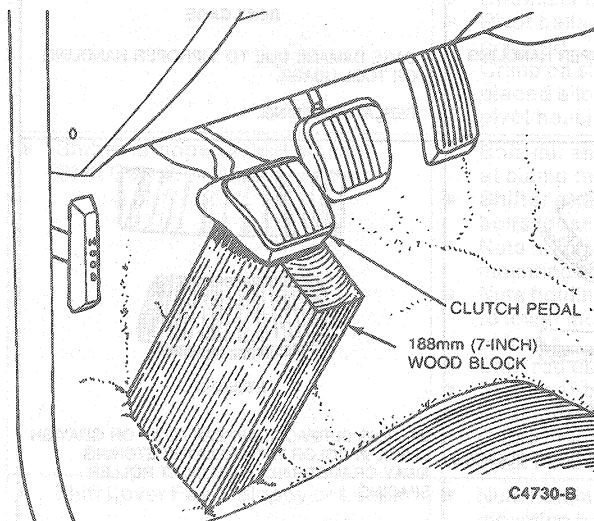

3. Remove air cleaner hose.
4. Grasp the clutch cable and pull forward, disconnecting it from the clutch release shaft assembly.

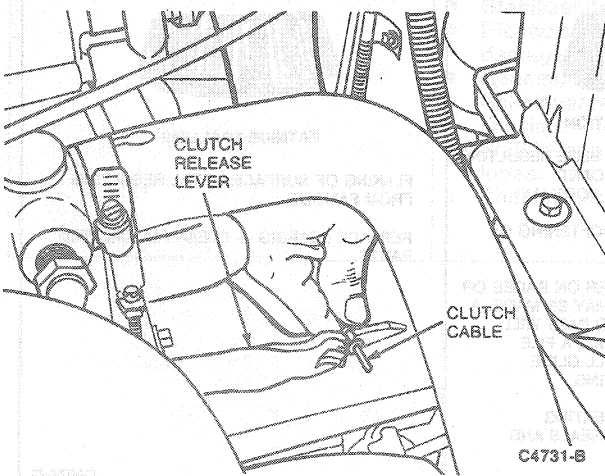

5. Disconnect the clutch cable casing from the rib on top surface of the transaxle case.
6. Install engine lifting eyes.
7. Tie up wiring harness and power steering cooler hoses.
8. Disconnect speedometer cable and speed sensor wire.
9. Support engine using Engine Support Bar 014-00750 or equivalent.
10. Raise vehicle on hoist. Refer to Section 00-02.
11. Remove wheel and tire assemblies.
12. Remove nut and bolt retaining lower control arm ball joint to the steering knuckle assembly. Discard the removed nut and bolt. Repeat procedure on the opposite side.

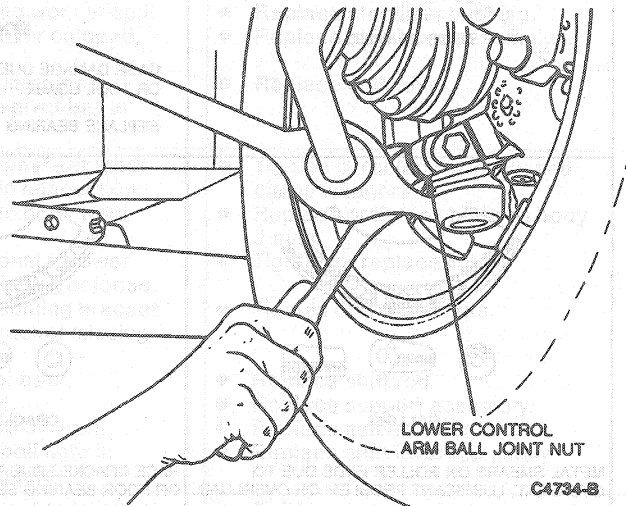

CAUTION: Exercise care not to damage or cut the ball joint boot. Pry bar must not contact the lower arm.

13. Using Halfshaft Remover D83P-4026-A or equivalent, pry the lower control arm away from knuckle. Repeat procedure on the opposite side.

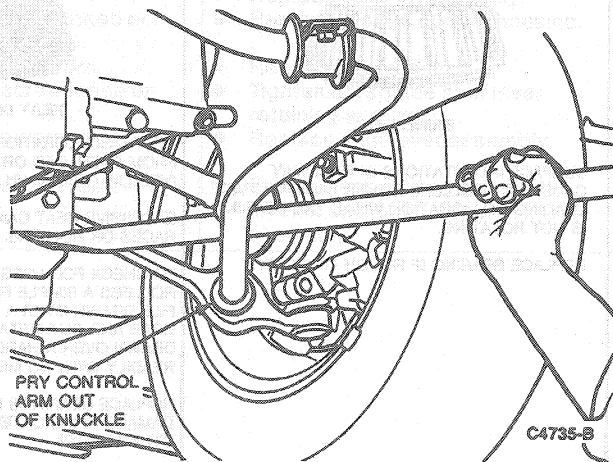

REMOVAL AND INSTALLATION (Continued)

14. Remove upper nut from stabilizer bar and separate the stabilizer from knuckle.
15. Remove tie rod nut and separate tie rod end from knuckle.
16. Disconnect heated oxygen (HO2S) 9F472. sensor.
17. Remove exhaust catalyst assembly.
18. Disconnect power steering cooler from subframe and place out of the way.
19. Disconnect battery cable bracket from subframe.

CAUTION: Use care when using the pry bar for removal of the CV joint assembly, to prevent damage to the differential oil seal. Repeat procedure on the RH side.

NOTE: Lubricant will drain from the seal at this time. Install Transaxle Plugs T8 1P-1177-B (two required).

20. Using a large pry bar, pry the LH inboard CV joint assembly from the transaxle.

NOTE: If the CV joint assembly cannot be pried from the transaxle, insert Differential Rotator T8 1P-4026-A through LH side and tap the joint out. Tool can be used from either side of transaxle.

Remove the inboard CV joint from the transaxle by grasping the LH steering knuckle and swinging the knuckle and halfshaft outward from the transaxle.

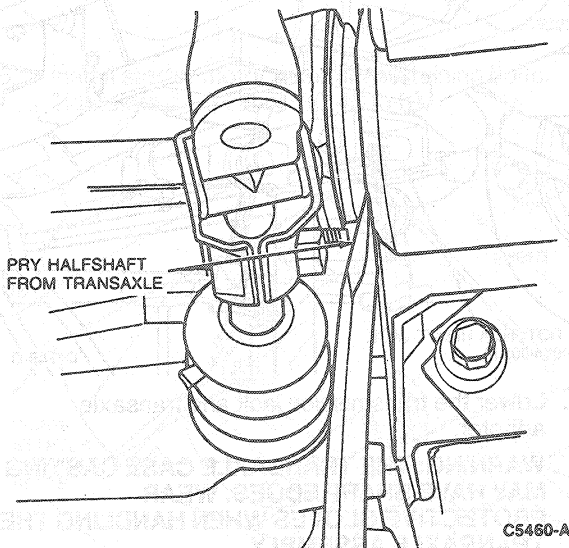

C5460-A

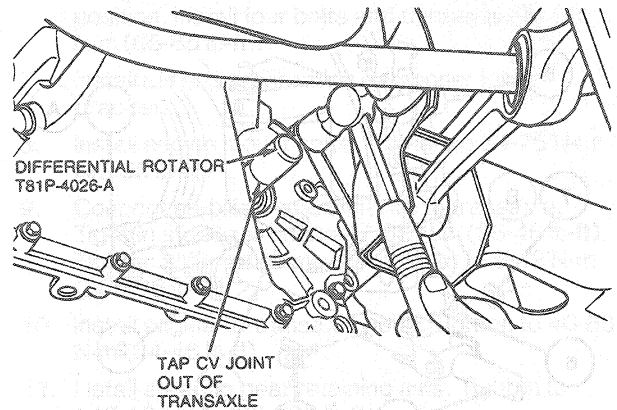

C5461-A

21. Wire the halfshaft assembly in a near level position to prevent damage to the assembly during remaining operations.

Repeat procedure on the opposite side.

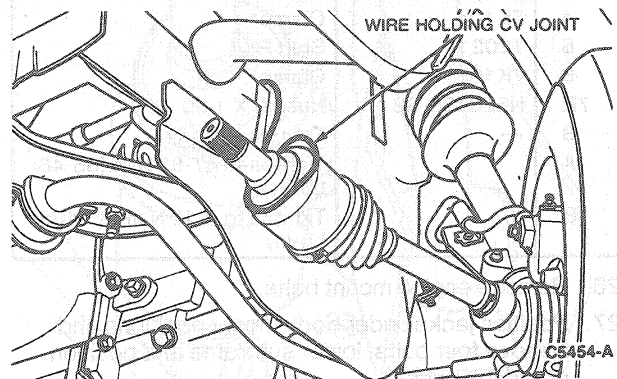

C5454-A

22. Remove retaining bolts from center support bearing and remove RH halfshaft from transaxle.
23. Remove two steering gear retaining nuts from subframe. Support steering gear by wiring up the tie rod ends to the coil springs.
24. Remove transaxle to engine retaining bolts.
25. Remove shift mechanism stabilizer bar-to-transaxle retaining bolt. Remove shift rod-to-shift shaft retaining nut and bolt. Remove rods from transaxle.

REMOVAL AND INSTALLATION (Continued)

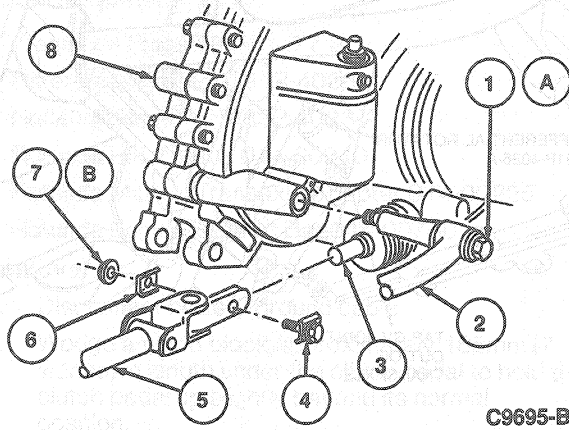

C9695-B

Item	Part Number	Description
1A	N601426	MH M12 X 1.75
2	7400	Stabilizer Shaft
3	7L267	Shift Shaft
4	7K104	Clamp
5	7202	Shift Rod
6	7K105	Clamp
7B	N620480-S2	Nut M6 X 1.00
8	—	Transaxle Assy
A		Tighten to 47-63 N·m (35-46 Lb·Ft)
B		Tighten to 9-12 N·m (80-106 Lb·In)

- 26. Remove engine mount bolts.
- 27. Position jacks under body mount positions and remove four bolts, lower subframe and position out of the way.
- 28. Remove starter motor assembly.

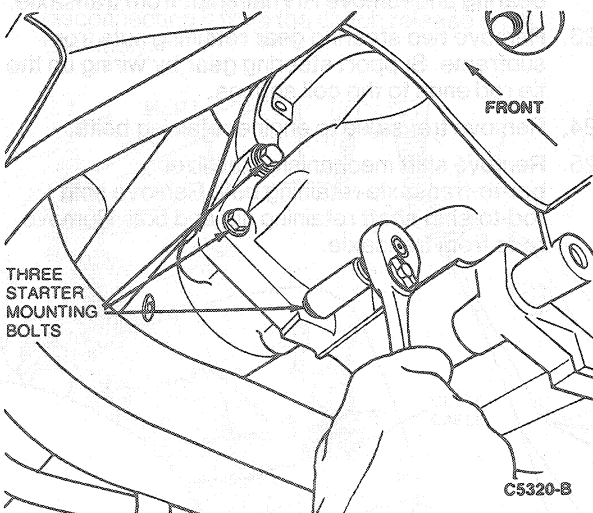

C5320-B

- 29. Remove LH engine vibration dampener lower bracket.

- 30. Using a small screwdriver, remove the backup lamp switch connector from the transaxle backup lamp switch, located on top of the transaxle.

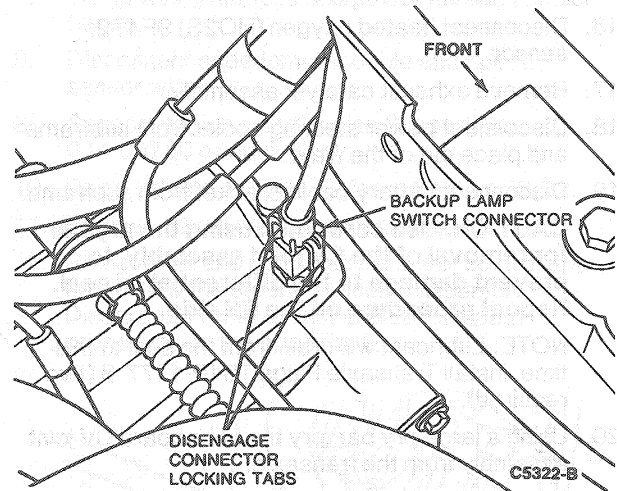

C5322-B

- 31. Remove backup lamp switch connector.
- 32. Position Rotunda Hi-Lift Jack 014-00210 and Rotunda Manual Transaxle Adapter 014-00225, or equivalent, under the transaxle.

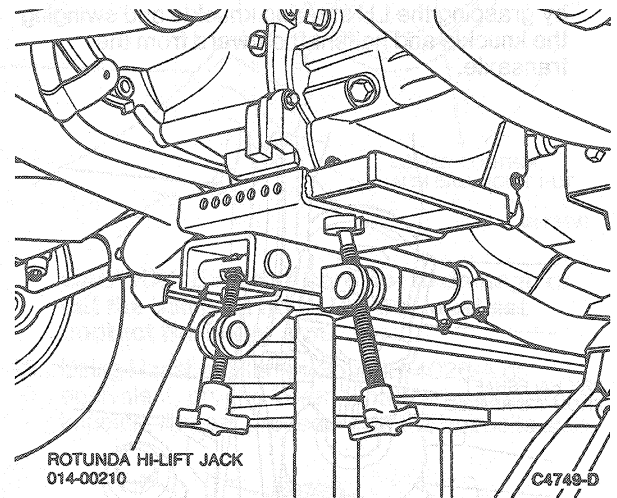

ROTUNDA HI-LIFT JACK
014-00210

C4749-D

- 33. Lower the transmission jack and transaxle adapter.
- WARNING: THE TRANSAXLE CASE CASTING MAY HAVE SHARP EDGES. WEAR PROTECTIVE GLOVES WHEN HANDLING THE TRANSAXLE ASSEMBLY.**
- 34. Remove the transaxle from the engine and lower it from the vehicle.

Installation

NOTE: Make sure that the transaxle assembly is flush with the rear face of the engine prior to installation of the retaining bolts.

REMOVAL AND INSTALLATION (Continued)

- Using Rotunda Hi-Lift Jack 014-00210 and Rotunda Manual Transaxle Adapter 014-00225 or equivalent, raise the transaxle into position. Engage the input shaft spline into the clutch disc and work the transaxle onto the dowel sleeves.

- Install the engine-to-transaxle retaining bolts. Tighten to 46-63 N·m (34-46 lb-ft).

WARNING: DO NOT ATTEMPT TO START THE ENGINE PRIOR TO INSTALLING THE CV JOINTS. DIFFERENTIAL SIDE GEAR DISLOCATION DAMAGE COULD RESULT.

- Install backup lamp switch. Tighten to 16-20 N·m (12-15 lb-ft).
- Connect the backup lamp switch connector.

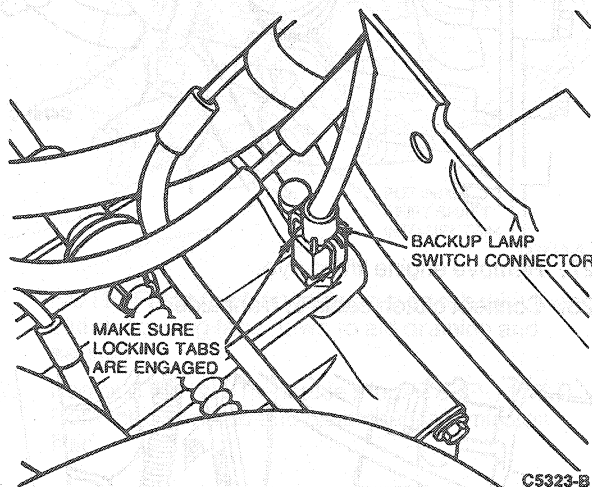

- Install starter motor assembly retaining bolts. Tighten to 41-54 N·m (30-40 lb-ft).

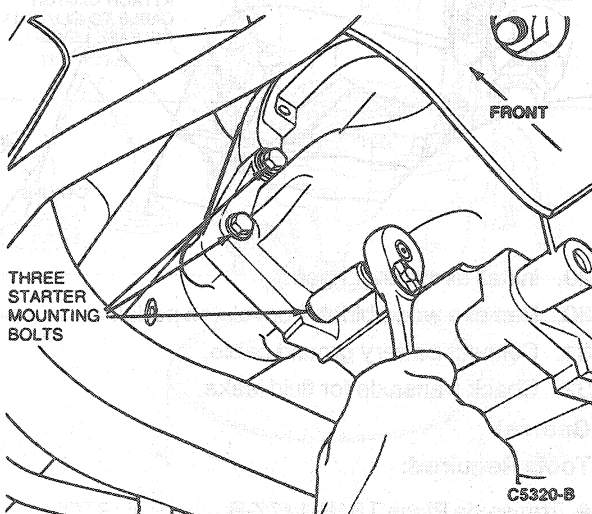

- Using jacks, position subframe and raise into position. Install four bolts and tighten to 90-115 N·m (65-85 lb-ft).
- Install LH engine vibration dampener lower bracket.
- Install engine mount bolts. Tighten to 54-75 N·m (40-55 lb-ft).
- Connect stabilizer and shift rod to transaxle. Tighten stabilizer bolt to 47-63 N·m (35-46 lb-ft). Tighten shift rod clamp bolt and nut to 9-12 N·m (80-106 lb-in).
- Install engine-to-transaxle bolts. Tighten to 46-63 N·m (34-46 lb-ft).
- Install steering gear retaining nuts. Tighten to 115-135 N·m (85-100 lb-ft).
- Install center support bearing retaining bolts. Tighten to 115-135 N·m (85-100 lb-ft).
- Install RH halfshaft into transaxle.
- Install LH inboard CV joint assembly into transaxle.

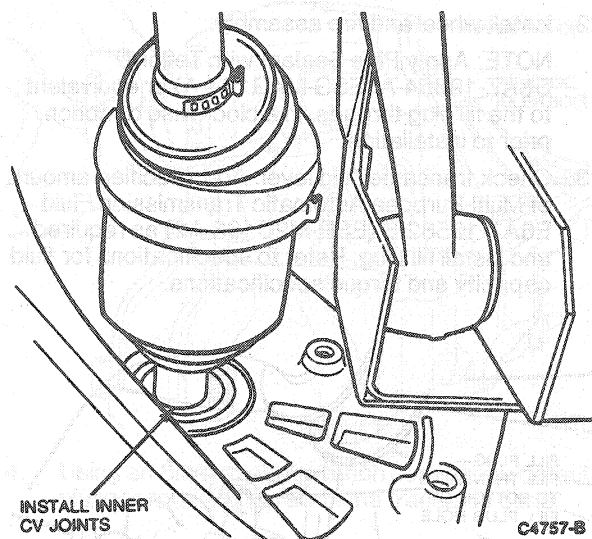

- Connect battery cable bracket to subframe.
- Connect power steering cooler to subframe.
- Install exhaust catalyst retaining bolts. Tighten to 34-47 N·m (25-34 lb-ft).
- Connect heated oxygen sensor (HO2S) 9F472.
- Install tie rod in knuckle and tie rod retaining nut. Tighten to 47-64 N·m (35-47 lb-ft).
- Position stabilizer bar to knuckle and install nut.

REMOVAL AND INSTALLATION (Continued)

21. Install lower control arm ball joint to steering knuckle assembly. Install a new retaining nut and bolt. Tighten to 50-60 N·m (37-44 lb-ft).

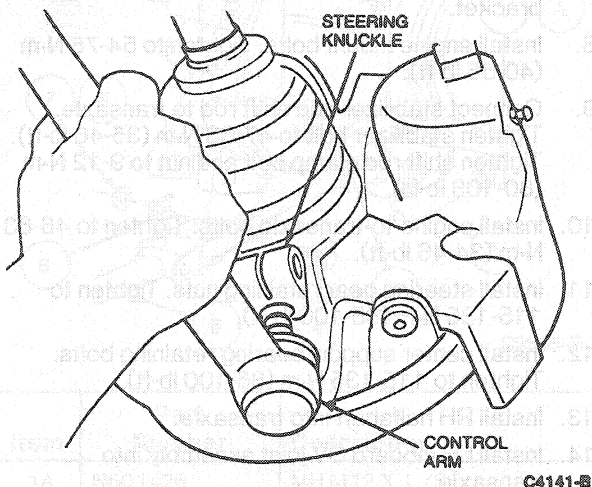

22. Install wheel and tire assembly.

NOTE: Apply Pipe Sealant with Teflon® D8AZ-19554-A (ESG-M4G 194-A) or equivalent to the fill plug threads, in a clockwise direction, prior to installation.

23. Check transaxle fluid level. Add specified amount of Multi-Purpose Automatic Transmission Fluid E6A7-19582-B (ESR-M2C 163-A2) as required and install fill plug. Refer to specifications for fluid capacity and torque specifications.

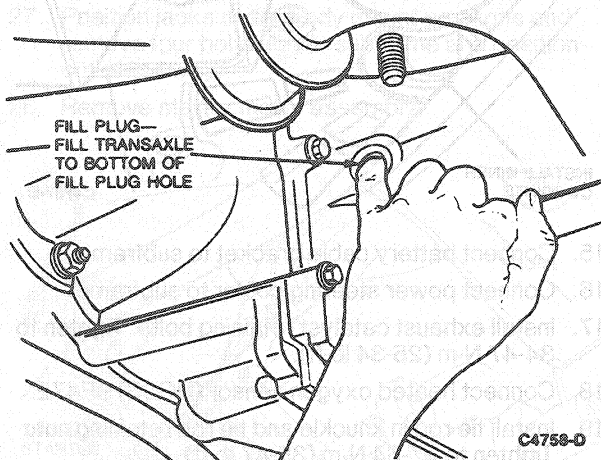

24. Lower vehicle.
 25. Remove Engine Support Bar 014-00750 or equivalent.
 26. Using a 22mm crowfoot wrench, install speedometer cable. Connect speedometer cable and speed sensor wire.

REMOVAL AND INSTALLATION (Continued)

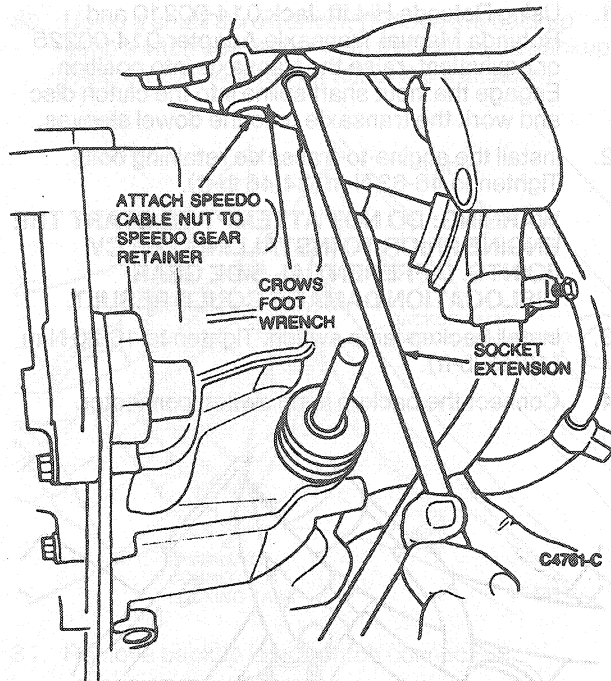

27. Remove engine lifting eye.
 28. Connect clutch cable to transaxle.

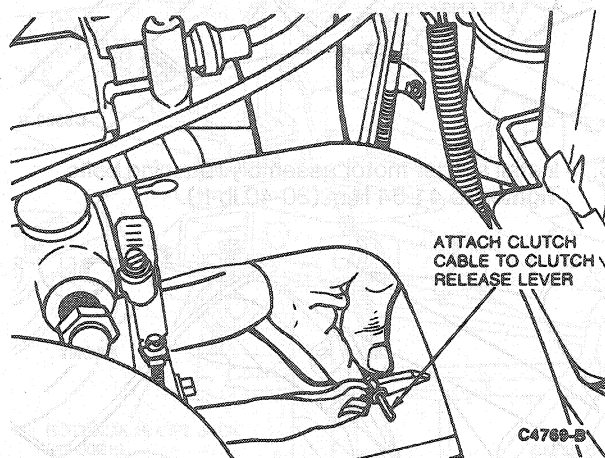

29. Install air cleaner hose.
 30. Remove wood block from clutch pedal.
 31. Connect battery ground cable.
 32. Check transaxle for fluid leaks.

Gearset

Tools Required:

- Transaxle Plugs T81P-1177-B

REMOVAL AND INSTALLATION (Continued)

Removal

- Using a drift in the input shift shaft hole, shift the transaxle into NEUTRAL. Pull or push the shaft into the center detent position (NEUTRAL).
The shift shaft will rotate slightly from side-to-side when positioned in NEUTRAL.

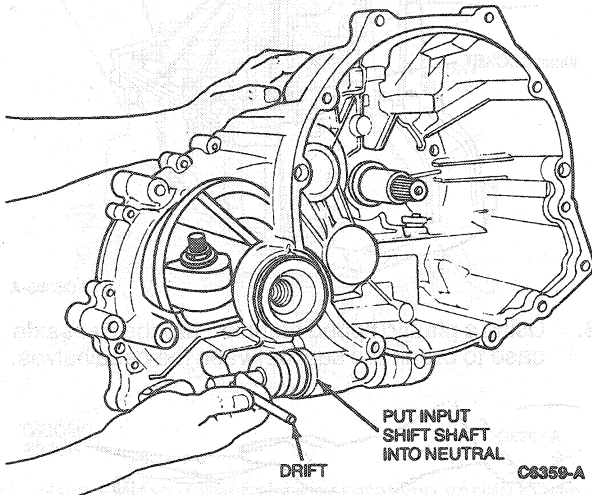

NOTE: Place the transaxle on a bench with the clutch housing face down to aid draining and service.

- Remove the two Transaxle Plugs T81P-1177-B from the transaxle and drain the transmission fluid.

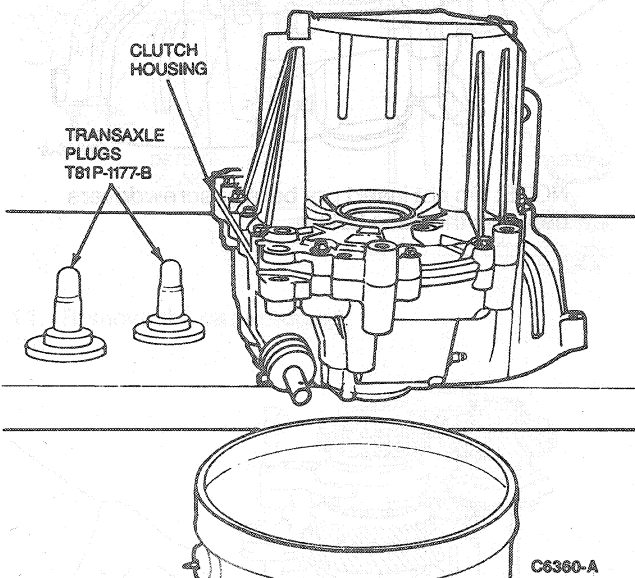

NOTE: If case half is being replaced, use a 22mm box-end wrench to remove the backup lamp switch assembly.

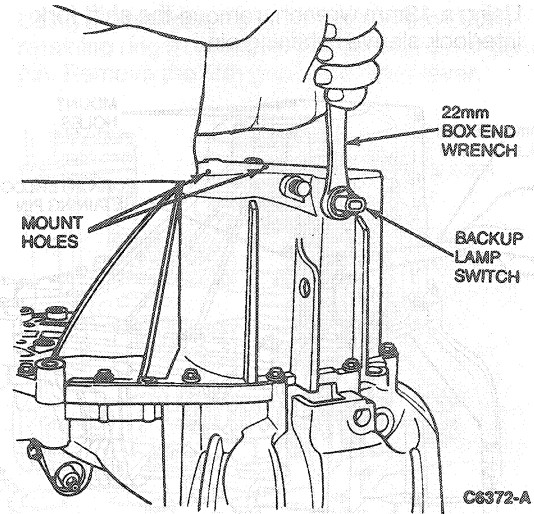

- Using a 13mm socket wrench, remove the reverse idler shaft retaining bolt.

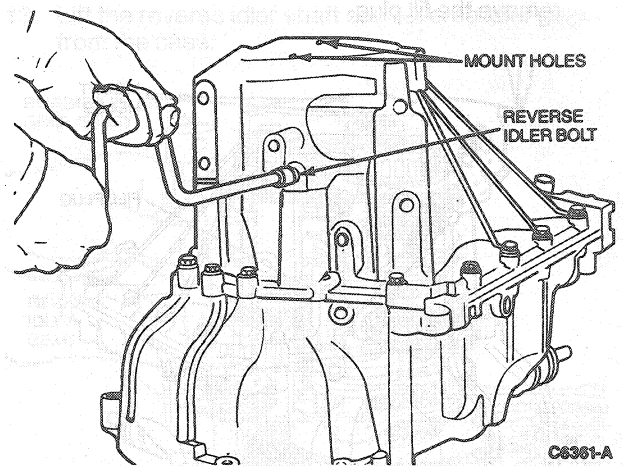

- Using an 8mm socket wrench, loosen the detent plunger retaining screw in the transaxle case.

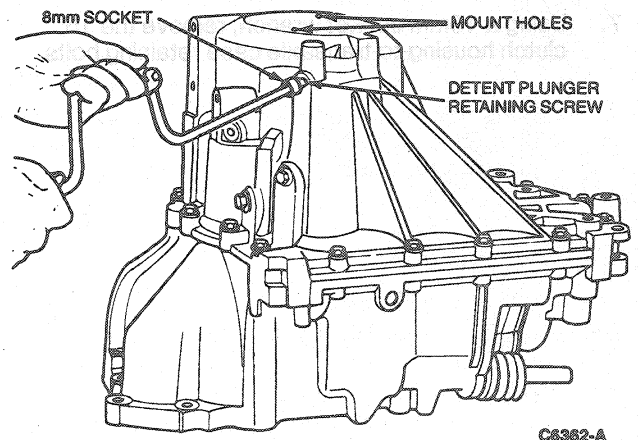

REMOVAL AND INSTALLATION (Continued)

- 5. Using a 13mm wrench, remove the shift fork interlock sleeve retaining pin.

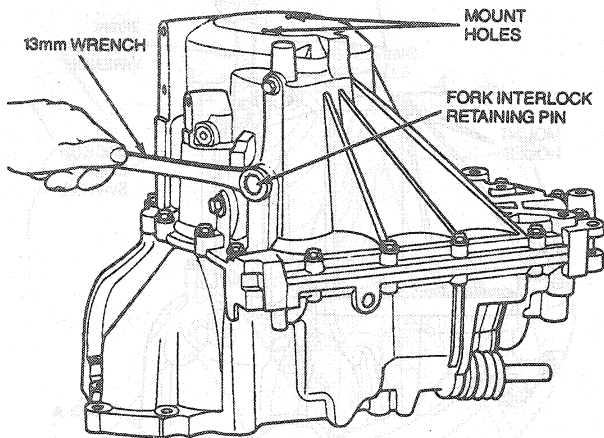

- 6. Using a 3/8-inch extension bar and ratchet, remove the fill plug.

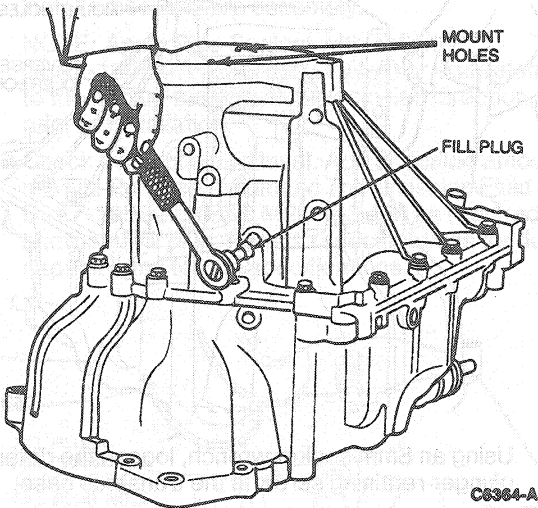

- 7. Using a 10mm socket wrench, remove the 15 clutch housing-to-transaxle case retaining bolts.

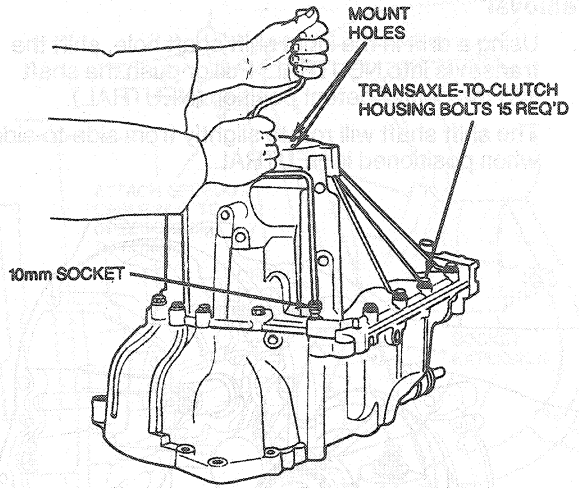

- 8. Using a plastic tipped hammer, tap the transaxle case to break the seal between the case halves.

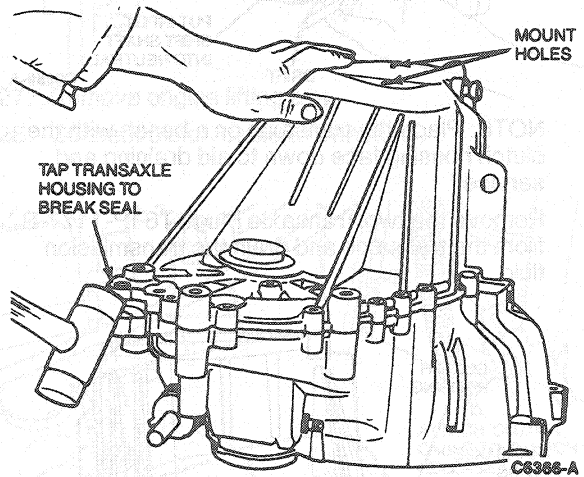

NOTE: Do not insert pry bars or screwdrivers between the case halves.

REMOVAL AND INSTALLATION (Continued)

14. Using a 5/32-inch punch, drive the spring pin from the shift lever shaft.

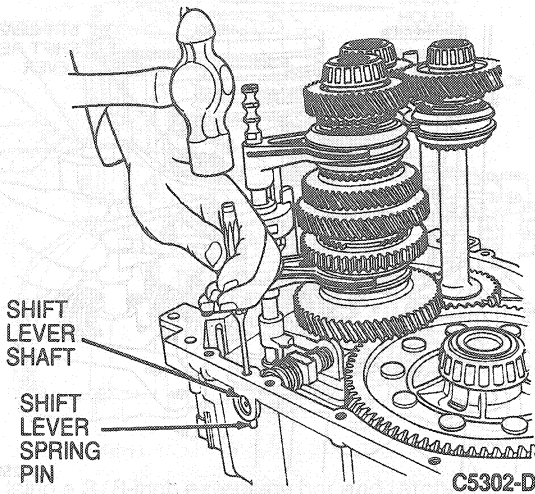

CAUTION: Be careful not to damage main shaft gear teeth or pedestal when prying with the screwdriver.

15. Using a screwdriver, gently pry on the shift lever shaft so that the hole in the shaft is exposed.

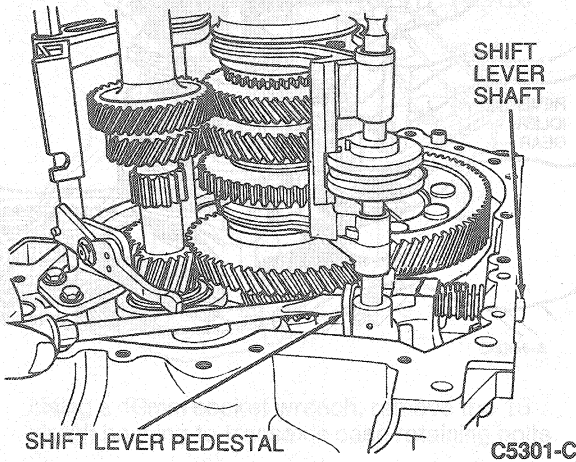

16. Hold a cloth over the hole in the lever to prevent the ball and spring from shooting out and remove the shift lever shaft.

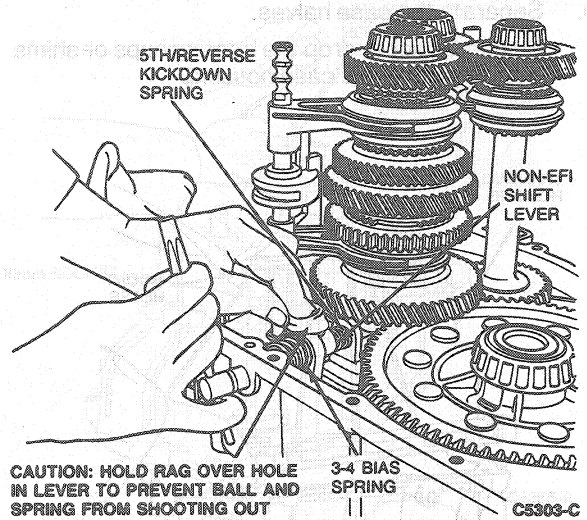

17. Remove the inhibitor ball and spring from the hole in the shift lever using a pencil magnet. Remove the shift lever, fifth/reverse kickdown spring, and 3/4 bias spring.

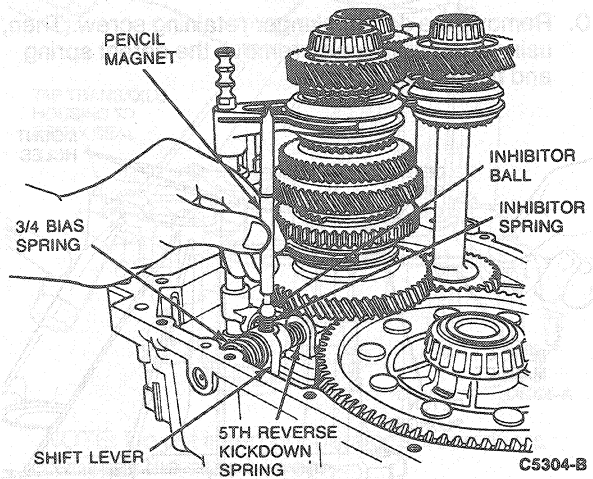

NOTE: Be careful not to drop bearings or gears (slip fit).

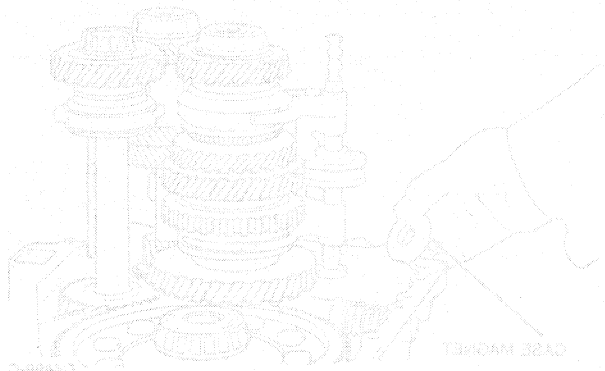

REMOVAL AND INSTALLATION (Continued)

18. Remove the main shaft assembly, input cluster shaft assembly and the main shift control shaft assembly as one unit.

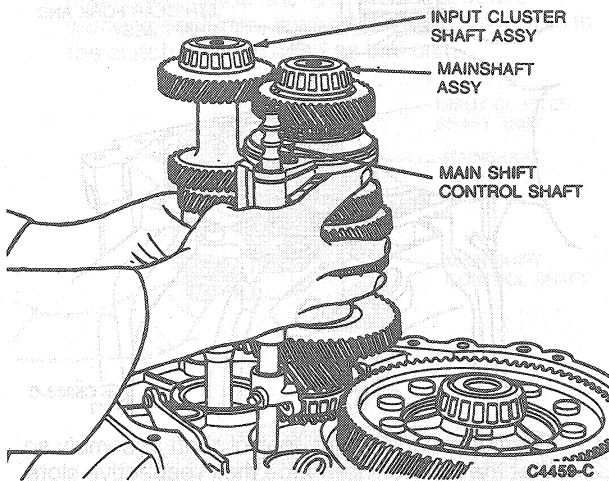

NOTE: Be careful not to drop bearings or gears (slip fit).

19. Remove the fifth gear shaft assembly and fifth gear fork assembly from their bores in the case.

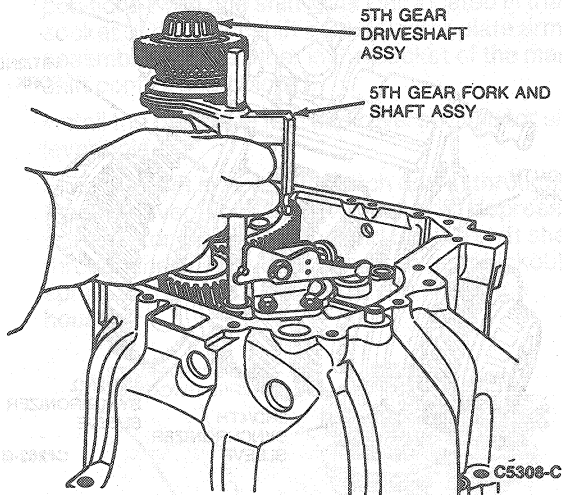

20. Lift the differential and final drive gear assembly from the clutch housing case.

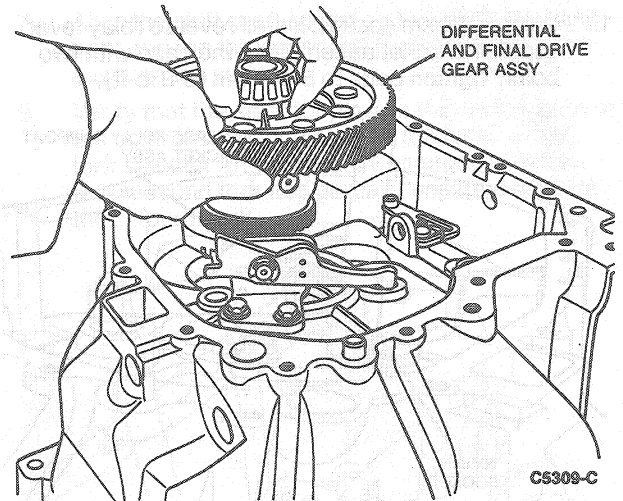

21. Using a 10mm socket, remove two bolts retaining reverse shift relay lever support bracket assembly.

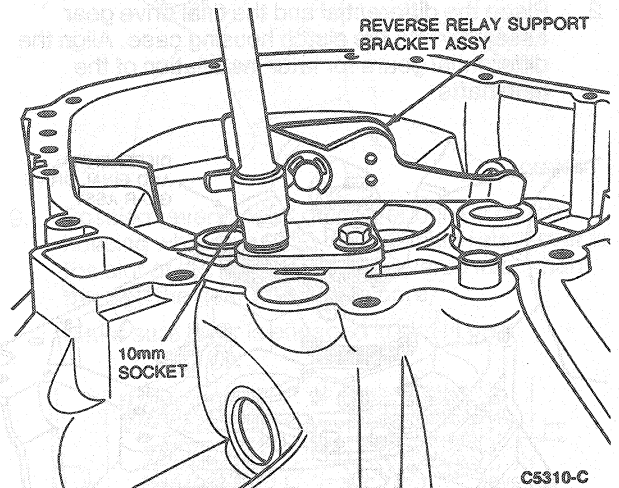
**Installation**

NOTE: Prior to installation, thoroughly clean all parts and inspect their condition. Lightly oil the bores with Synthetic MERCON® Multi-Purpose Automatic Transmission Fluid E6AZ-19582-B (ESR-M2C 163-A2) or equivalent.

REMOVAL AND INSTALLATION (Continued)

- Using a 10mm socket, install reverse relay lever support bracket assembly to the case with two bolts. Tighten bolts to 8-11 N·m (6-8 lb-ft).

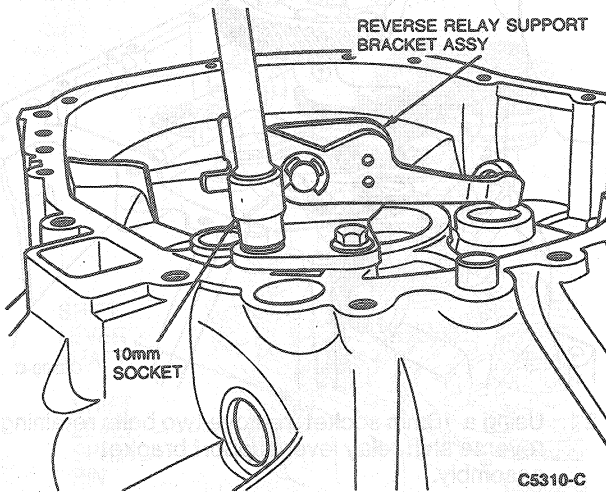

- Place the differential and the final drive gear assembly into the clutch housing case. Align the differential gears for later installation of the halfshafts.

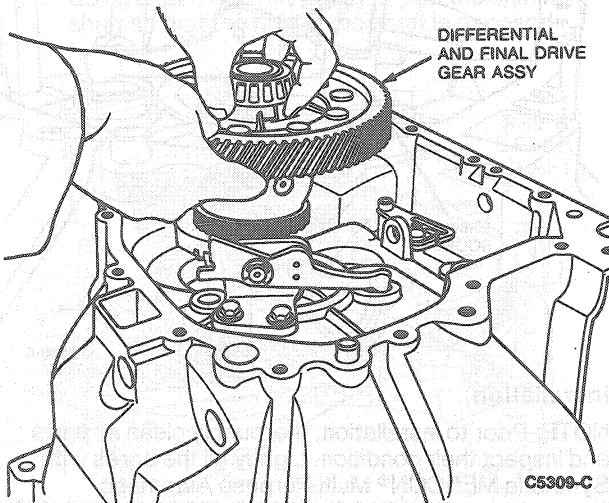

CAUTION: Be careful not to damage the fifth gear shaft oil funnel.

- Install the fifth gear shaft assembly and the fork shaft assembly in the case.

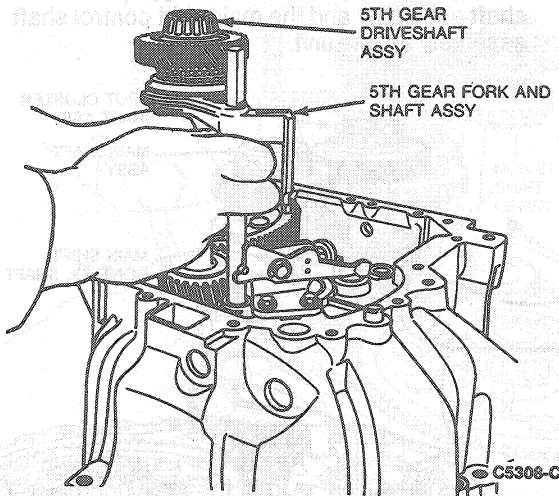

- Position the main shift control shaft assembly so that the shift forks engage their respective slots in the synchronizer sleeves on the main shaft assembly.

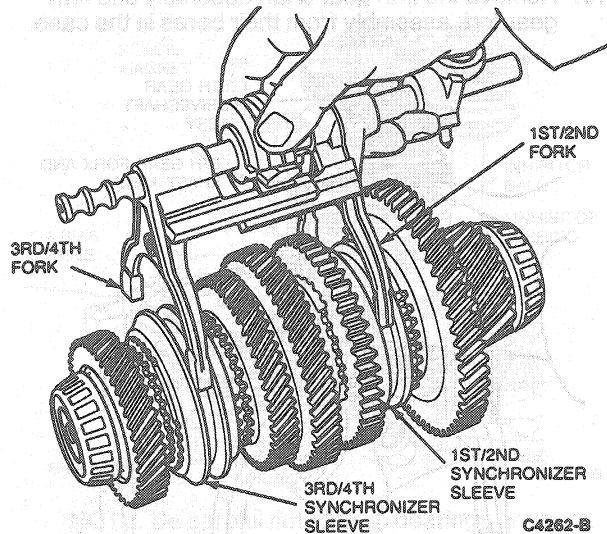

CAUTION: Be careful not to damage the input shaft oil seal or main shaft oil funnel.

NOTE: When performing this operation, care must be taken to avoid movement of the third/fourth synchronizer sleeve. This could result in overtravel of the synchronizing sleeve to hub, allowing inserts to pop out of position.

REMOVAL AND INSTALLATION (Continued)

- Bring the main shaft assembly into mesh with the input cluster shaft assembly. Holding the three shafts (input cluster shaft, main shaft and the main shift control shaft) in their respective working positions, lower them into their bores in the clutch housing case as one unit.

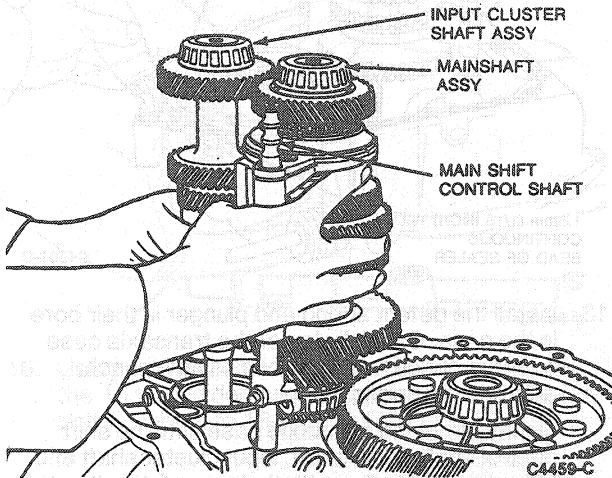

- Position the shift lever, 3/4 bias spring and fifth/reverse kickdown spring in their working positions (with one shift lever ball located in the socket of the input shift gate selector plate arm assembly and the other in the socket of the main shift control shaft block).

Install the ball in the fifth and reverse inhibitor shift lever hole.

Slide the shift lever shaft (notch down) through the shift lever. Then using a small drift, depress the inhibitor ball and spring and tap the shift shaft through the shift lever and the fifth gear kickout spring and then tap into its bore in the clutch housing.

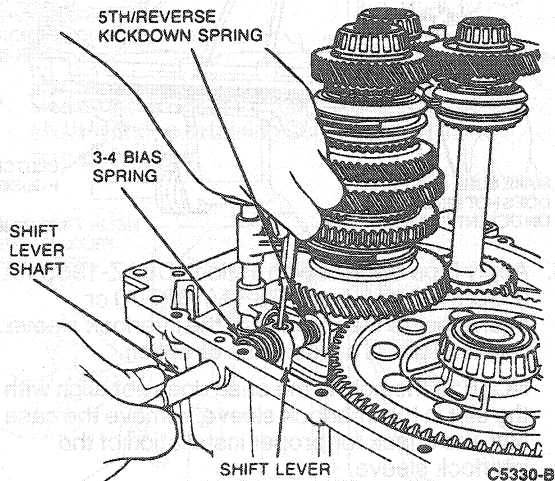

- Align the shift shaft spring pin hole with the case bore and tap the spring pin in, slightly below the case mating surface.
- Verify that the selector pin is in the neutral gate of the control selector plate and the finger of the fork selector arm is partially engaged with the first / second fork and partially engaged with the third / fourth fork.

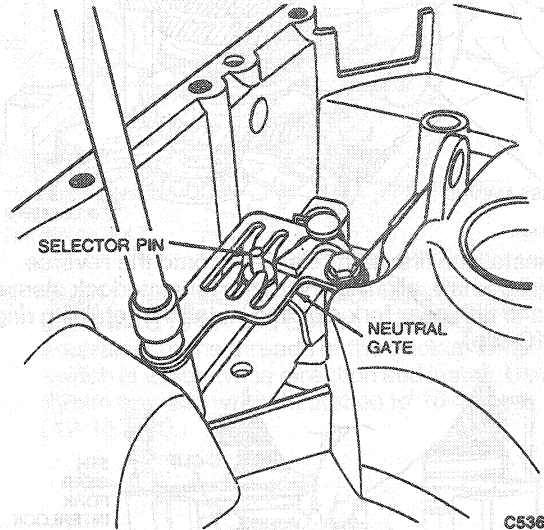

- Position reverse idler gear over bore in clutch housing while engaging reverse shift relay lever in the slot of the gear. Slide the reverse idler shaft through the gear and into its bore. Make sure lever is engaged in slot in gear.

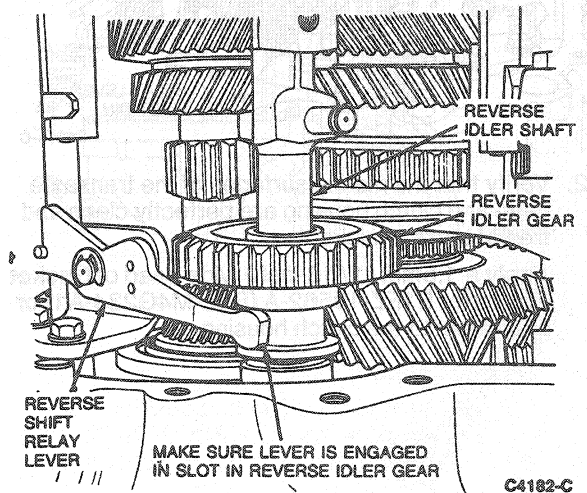

REMOVAL AND INSTALLATION (Continued)

10. Install the magnet in its pocket in the clutch housing case.

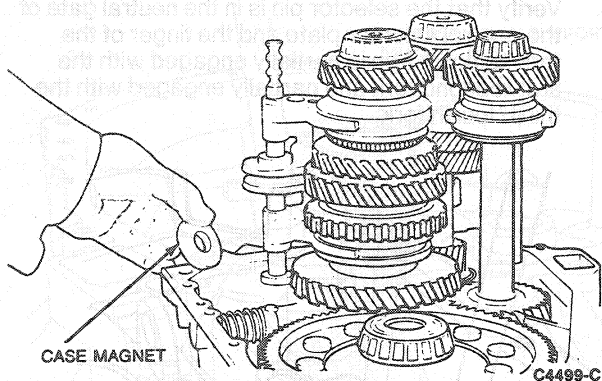

11. Install the fifth shift relay lever onto the reverse idler shaft, aligning it with the fork interlock sleeve and fifth gear fork slot and install the retaining ring (C-clip).

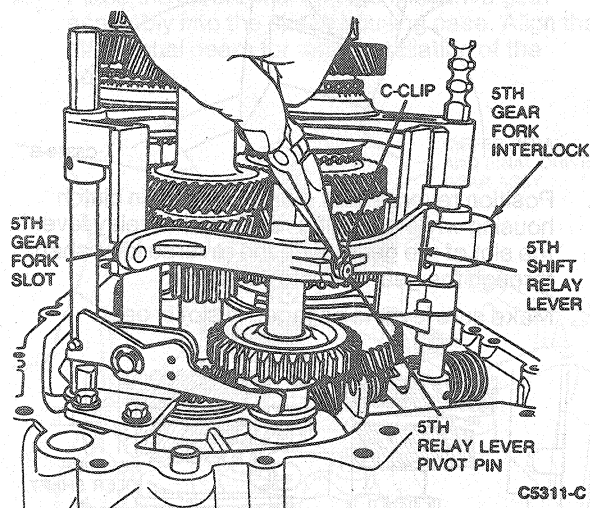

12. Verify that the mating surfaces of the transaxle case and clutch housing are perfectly clean and free of burrs or nicks.

Apply a 1.5mm (1/16-inch) wide bead of Gasket Eliminator E1FZ-19562-A (ESE-M4G234-A1) or equivalent to the clutch housing.

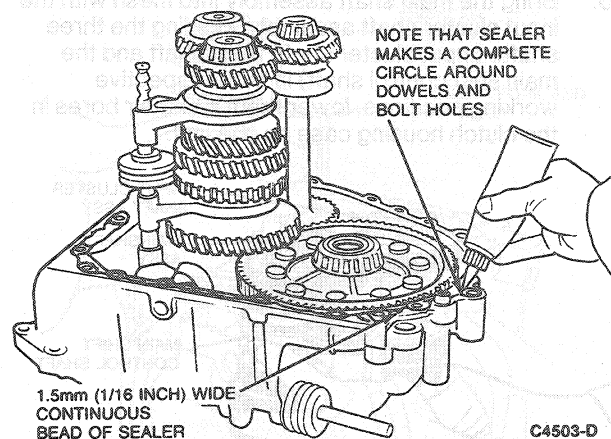

13. Install the detent spring and plunger in their bore in the case. Carefully lower the transaxle case over the clutch housing, then using a punch, depress the spring and plunger.

Gently move the transaxle case until the shift control shaft, main shaft, input cluster shaft and fifth gear shaft align with their respective bores in the transaxle case.

14. Gently slide the transaxle case over the dowels and flush onto the clutch housing case. Make sure that the case does not bind on the magnet.

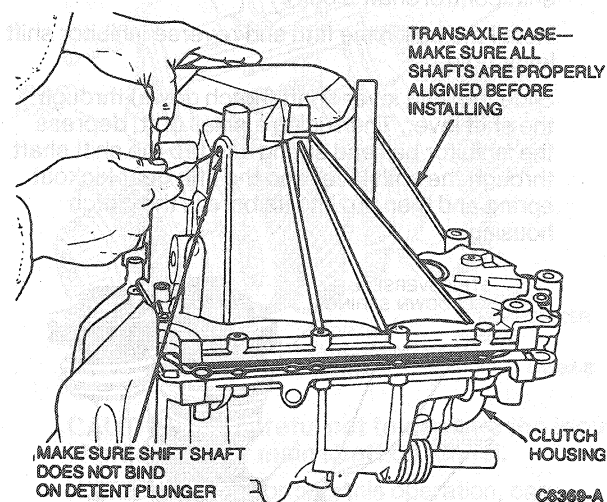

15. Apply Pipe Sealant with Teflon® D8AZ-19554-A (ESG-M4G194-A and ESR-M18P7-A) or equivalent to the threads of the interlock sleeve retaining pin, in a clockwise direction.

NOTE: If the hole in the case does not align with the slot in the interlock sleeve, remove the case half and check for proper installation of the interlock sleeve.

Use a drift to align the slot in the interlock sleeve with the hole in the transaxle case and install the retaining pin.

REMOVAL AND INSTALLATION (Continued)

Using a 13mm socket, tighten to 16-20 N·m (12-15 lb-ft).

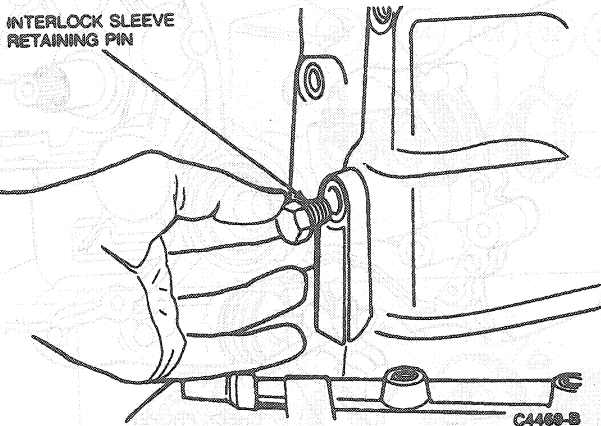

16. Using a 10mm socket and torque wrench, install the 15 transaxle case-to-clutch housing retaining bolts. Tighten to 18-24 N·m (13-17 lb-ft).

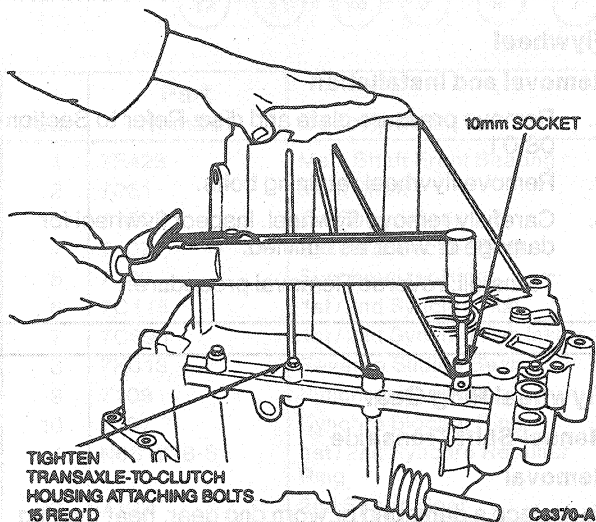

17. Use a drift to align the bore in the reverse idler shaft with the retaining screw hole in the transaxle case.

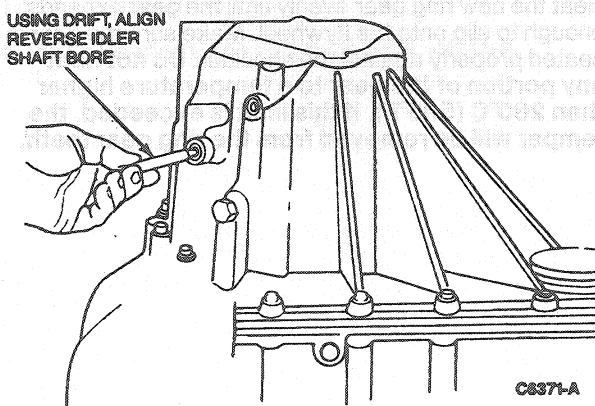

18. Install the reverse idler shaft retaining bolt. Tighten to 21-27 N·m (16-20 lb-ft).

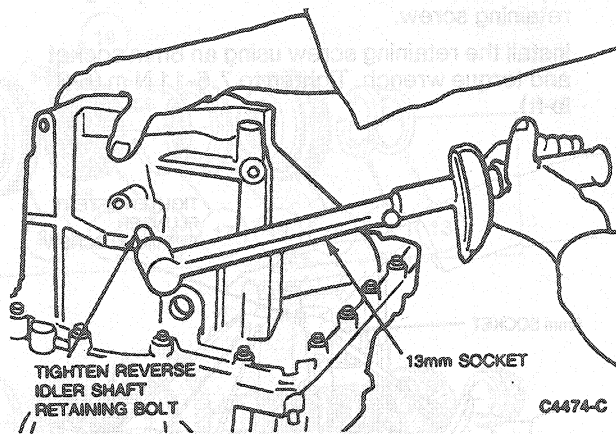

19. Apply Pipe Sealant with Teflon® D8AZ-19554-A (ESG-M4G194-A and ESR-M187P7-A) or equivalent to the threads of the backup lamp switch in a clockwise direction and install. Using a 22mm box-end wrench, tighten to 16-20 N·m (12-15 lb-ft).

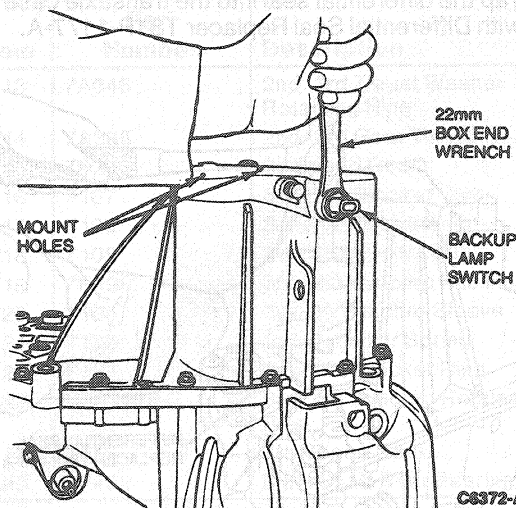

NOTE: Transaxle will not shift directly into REVERSE from 1st gear.

22. Place the transaxle upright and position a drift through the hole in the front shaft. Shift the transaxle in and out of all gears to verify proper installation.

NOTE: Install the transaxle fill plug after the transaxle has been installed in the vehicle and fluid has been added. Apply Pipe Sealant with Teflon® D8AZ-19554-A (ESG-M4G194-A) or equivalent to the fill plug threads, in a clockwise direction prior to installation. Refer to operation for fluid capacity and torque specifications.

REMOVAL AND INSTALLATION (Continued)

20. Apply Pipe Sealant with Teflon® D8AZ-19554-A (ESG-M4G 194-A and ESR-M187P7-A) or equivalent to the threads of the detent plunger retaining screw.

Install the retaining screw using an 8mm socket and torque wrench. Tighten to 7.5-11 N·m (6-8 lb-ft).

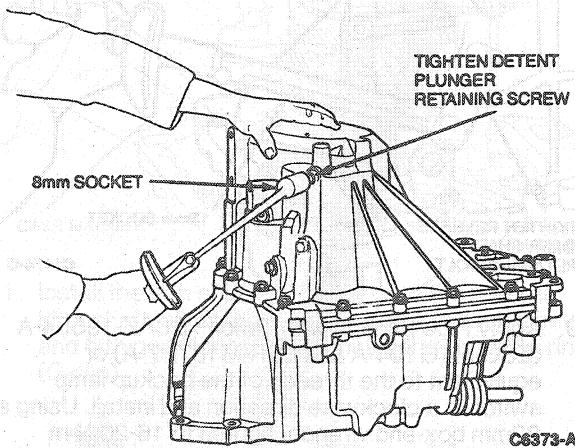

21. Tap the differential seal into the transaxle case with Differential Seal Replacer T81P-1177-A.

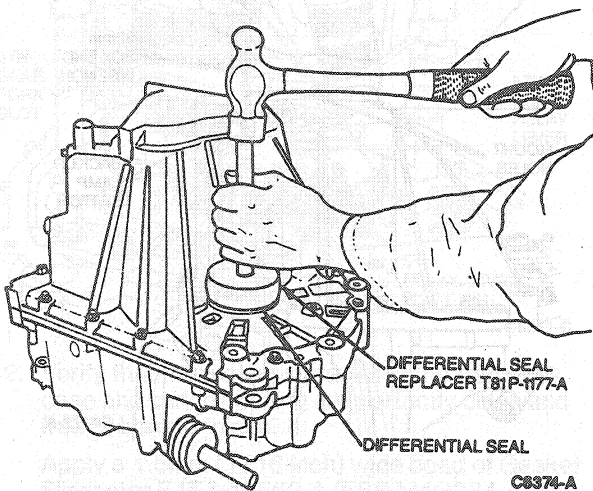

NOTE: Transaxle will not shift directly into REVERSE from fifth gear.

22. Place the transaxle upright and position a drift through the hole in the input shift shaft. Shift the transaxle in and out of all gears to verify proper installation.

NOTE: Install the transaxle fill plug after the transaxle has been installed in the vehicle and fluid has been added. Apply Pipe Sealant with Teflon® D8AZ-19554-A (ESG-M4G 194-A) or equivalent to the fill plug threads, in a clockwise direction, prior to installation. Refer to specifications for fluid capacity and torque specifications.

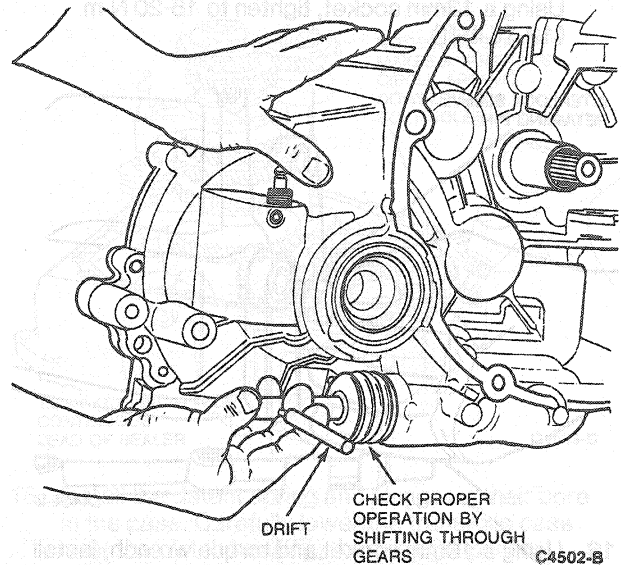

Flywheel

Removal and Installation

1. Remove pressure plate and disc. Refer to Section 08-01.
2. Remove flywheel retaining bolts.
3. Carefully remove flywheel. Inspect flywheel for damage or wear as outlined.
4. To install, reverse Removal procedure.

Flywheel Ring Gear

Manual-Shift Transaxle

Removal

To replace a damaged or worn ring gear, heat the ring gear with a blow torch on the engine side of the gear, and knock it off the flywheel. Do not hit the flywheel when removing the ring gear.

Installation

Heat the new ring gear evenly until the gear expands enough to slip onto the flywheel. Make sure the gear is seated properly against the shoulder. Do not heat any portion of the gear to a temperature higher than 260°C (500°F). If this limit is exceeded, the temper will be removed from the ring gear teeth.

DISASSEMBLY AND ASSEMBLY

Main Shaft Assembly

Main Shaft Disassembled View

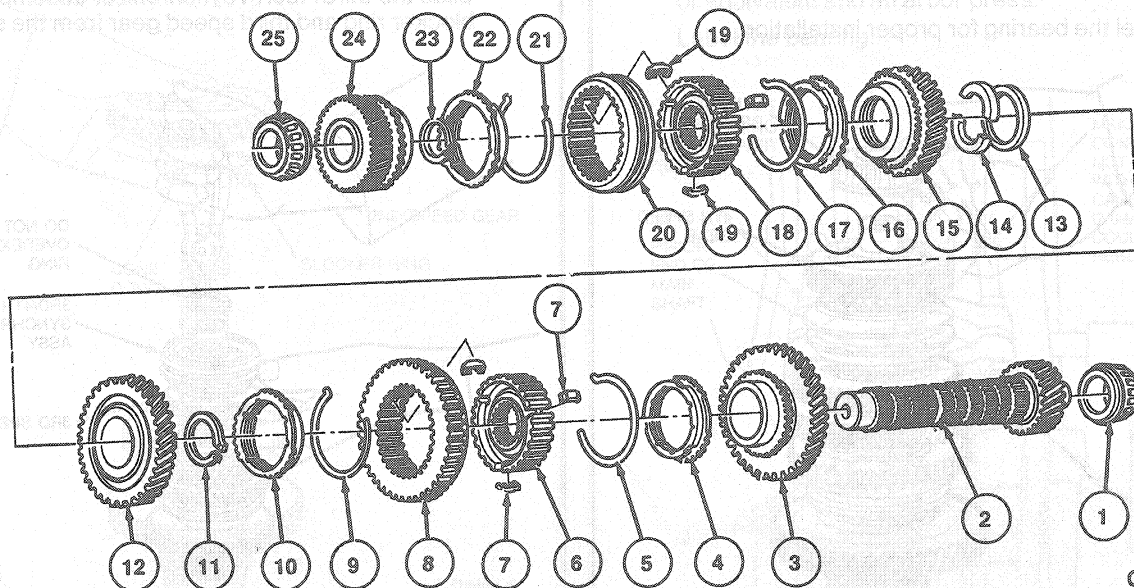

C3979-H

Item	Part Number	Description
1	7F423	Main Shaft Front Bearing
2	7061	Main Shaft
3	7100	1st Speed Gear
4	7107	Synchro Blocker Ring
5	7109	Synchronizer Ring
6	7C115	1st / 2nd Synchro Hub
7	7C396	1st / 2nd Synchro Hub Insert
8	7K013	Reverse Sliding Gear
9	7109	Synchronizer Spring
10	7107	Synchro Blocker Ring
11	N661228-S	1st / 2nd Synchro Retainer Ring
12	7102	2nd Speed Gear

(Continued)

Item	Part Number	Description
13	7A046	2nd / 3rd Thrust Washer Retaining Ring
14	7A385	2nd / 3rd Gear Thrust Washer
15	7B340	3d Speed Gear
16	7107	Synchro Blocker Ring
17	7109	Synchronizer Spring
18	7105	3d / 4th Synchro Hub
19	7K198	3rd / 4th Synchro Hub Insert
20	7106	3d / 4th Synchro Sleeve
21	7109	Synchronizer Spring
22	7107	Synchro Blocker Ring
23	N661226-S	3rd / 4th Synchro Retainer Ring
24	7110	4th Speed Gear
25	7F432	Main Shaft Rear Bearing

Tools Required:

- Pinion Bearing Cone Remover D79L-4621-A

NOTE: This bearing does not have to be removed to change the main shaft, only replace if damaged. Refer to Bearing Diagrams.

NOTE: Tag blocker ring for proper installation POSITION ON SHAFT SO THAT PLASTIC SPACER AND RETAINER IS FACING THE 5TH DRIVE BEAR.

DISASSEMBLY AND ASSEMBLY (Continued)

Disassembly

1. Remove the slip fit bearing on the fourth speed gear end of the shaft.
Label the bearing for proper installation.

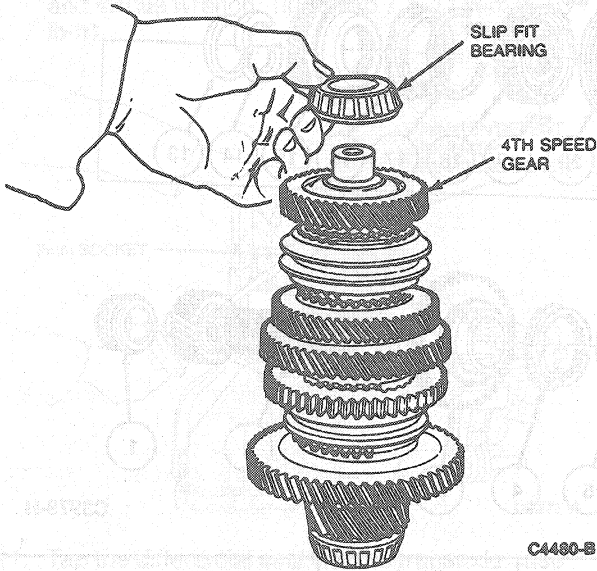

NOTE: Tag blocker ring for proper installation.

2. Remove the fourth speed gear and synchronizer blocker ring.

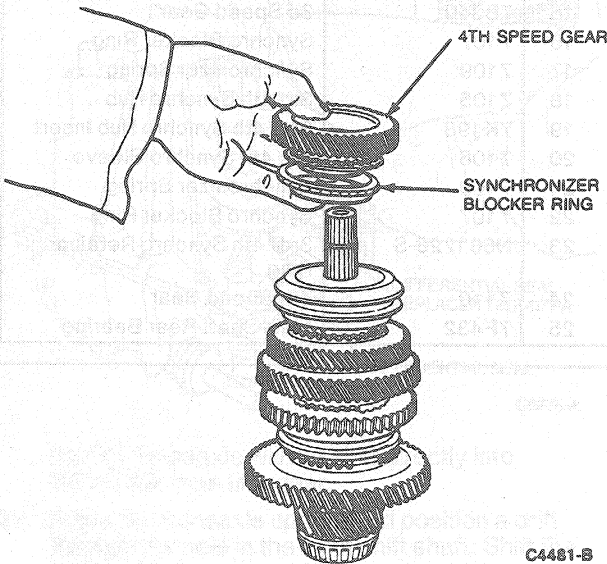

NOTE: Tag blocker ring for proper installation.

3. Remove the third/fourth synchronizer retaining ring.
Slide the third/fourth synchronizer assembly, blocker ring and third speed gear from the shaft.

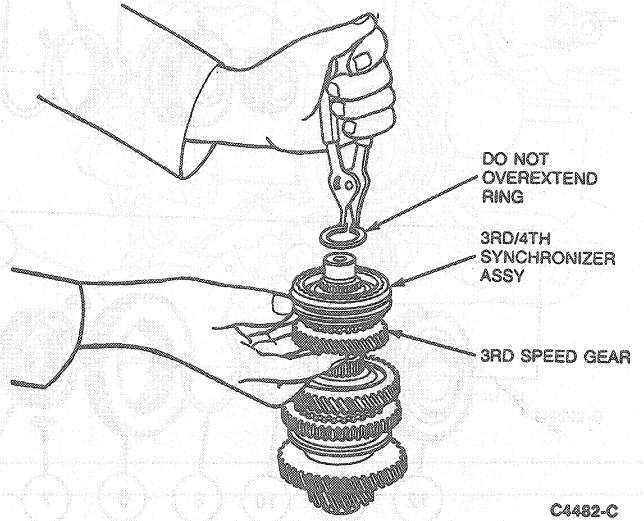

4. Remove the second/third thrust washer retaining ring and the two-piece thrust washer.

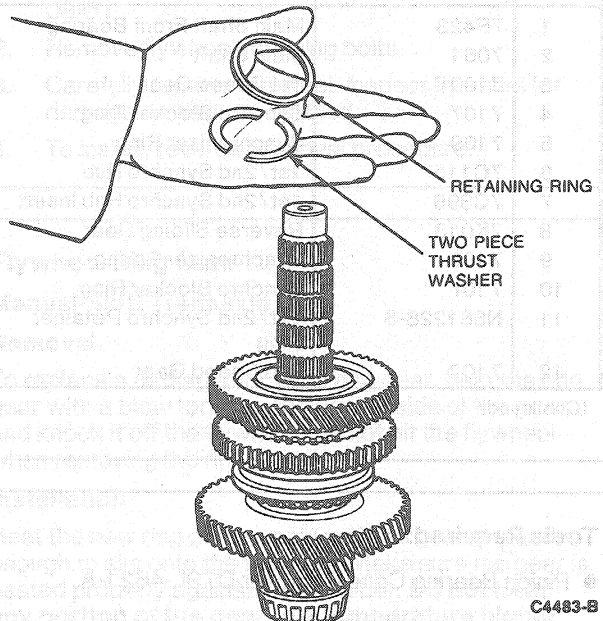

NOTE: Tag blocker ring for proper installation.

DISASSEMBLY AND ASSEMBLY (Continued)

5. Remove the second speed gear and its blocker ring.

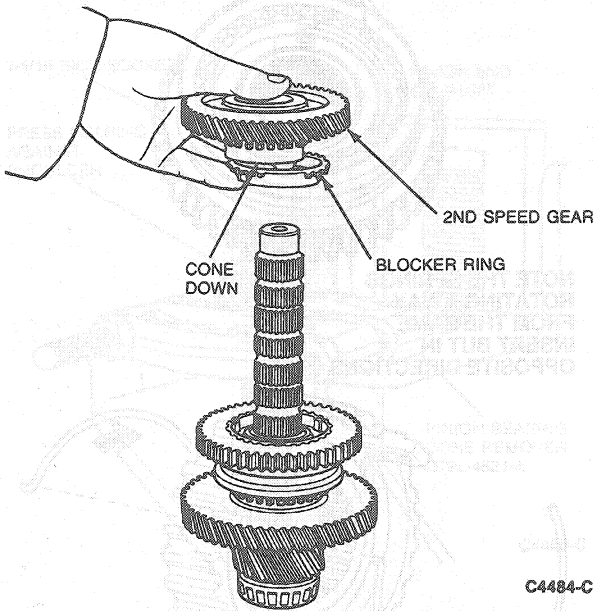

NOTE: Tag blocker ring for proper installation.

6. Remove the first / second synchronizer retaining ring. Slide the first / second synchronizer assembly, blocker ring and first speed gear off the shaft.

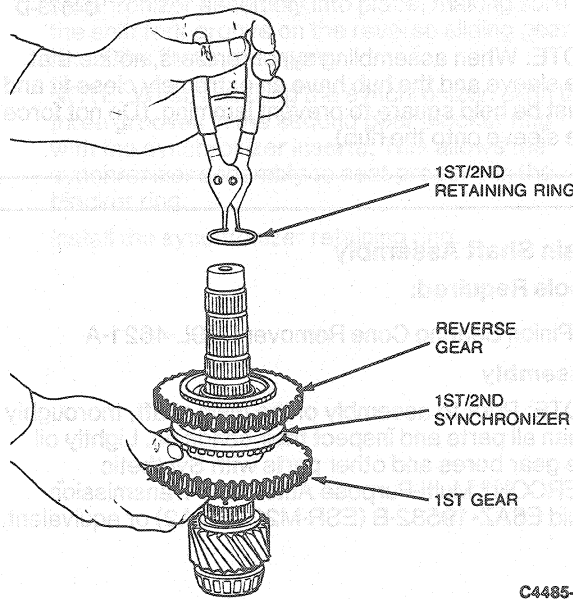

NOTE: This bearing does not have to be removed to disassemble the main shaft, only replace if damaged. Refer to Bearing Diagnosis.

7. Remove the tapered roller bearing from the pinion end of the main shaft using a socket or extension and Pinion Bearing Cone Remover D79L-4621-A or equivalent and an arbor press.

Label the bearing.

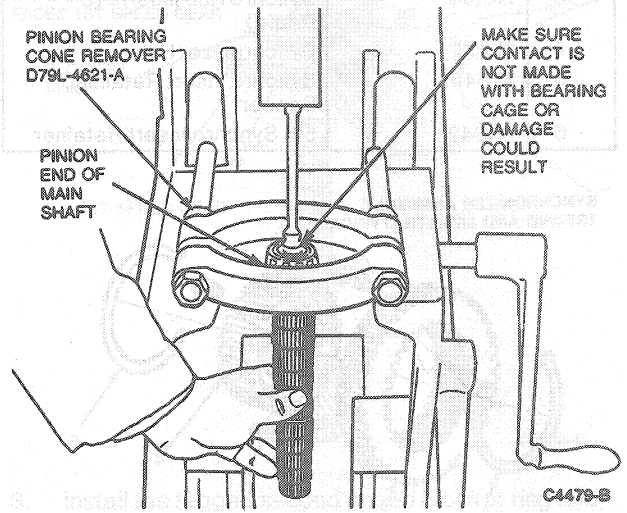

Synchronizer

Disassembly and Assembly

NOTE: Prior to disassembly note position of index marks.

To disassemble the synchronizer assembly, remove the synchronizer springs with a small screwdriver. Do not compress the springs more than necessary. Remove the three hub inserts. Slide the hub and sleeve apart.

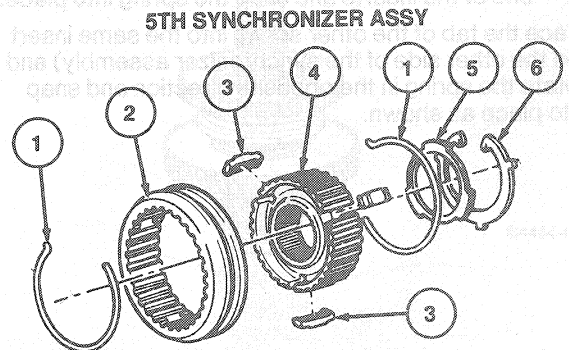

NOTE: THE 5TH SYNCHRONIZER IS POSITIONED ON SHAFT SO THAT PLASTIC SPACER AND RETAINER IS FACING THE 5TH DRIVE GEAR

C4174-E

DISASSEMBLY AND ASSEMBLY (Continued)

Item	Part Number	Description
1	7109	Synchro Retainer Spring (2 Req'd)
2	7106	Synchronizer Sleeve
3	7K198	Synchro Hub Inserts (3 Req'd)
4	7L172	Synchronizer Hub
5	7L049	Synchro Insert Retaining Spacer
6	7G042	5th Synchro Insert Retainer

**SYNCHRONIZER ASSEMBLY
1ST/2ND AND 3RD/4TH (TYPICAL)**

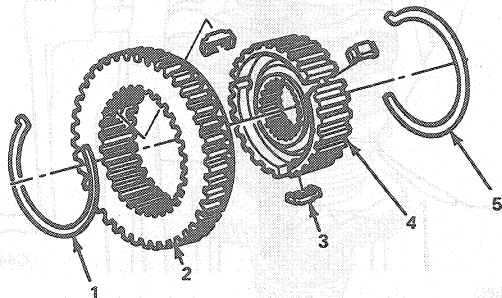

LEGEND:

1. SPRING — SYNCHRONIZER RETAINER
2. GEAR AND SYNCHRONIZER SLEEVE
3. INSERTS — SYNCHRONIZER HUB
4. HUB — SYNCHRONIZER
5. SPRING — SYNCHRONIZER RETAINER

C4072-D

In assembling the synchronizers, some points must be noted:

1. Slide the sleeve over the hub. The index marks must be aligned.
2. Place the three inserts into their slots. Place the tab on the synchronizer spring into the groove of one of the inserts and snap the spring into place.

Place the tab of the other spring into the same insert (on the other side of the synchronizer assembly) and rotate the spring in the opposite direction and snap into place as shown.

**ALIGNMENT MARKS
(SINGLE SET OF MARKS)**

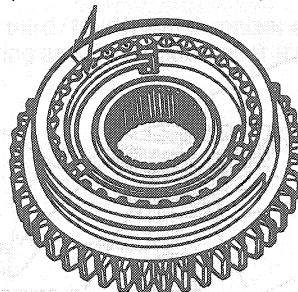

**NOTE THE SPRINGS
ROTATING AWAY
FROM THE SAME
INSERT BUT IN
OPPOSITE DIRECTIONS**

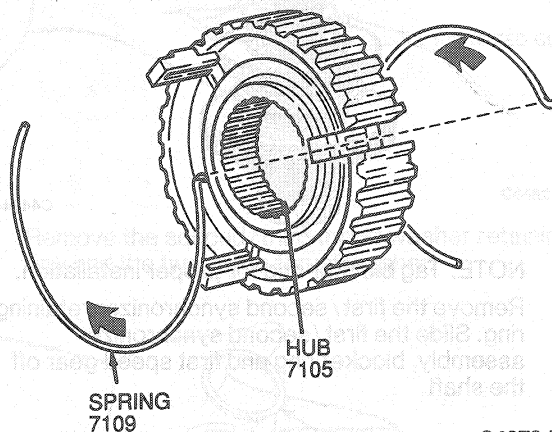

C4073-D

NOTE: When assembling synchronizers, notice that the sleeve and the hub have an extremely close fit and must be held square to prevent jamming. (Do not force the sleeve onto the hub).

Main Shaft Assembly

Tools Required:

- Pinion Bearing Cone Remover D79L-4621-A

Assembly

NOTE: Prior to assembly of the main shaft, thoroughly clean all parts and inspect their condition. Lightly oil the gear bores and other parts with Synthetic MERCON® Multi-Purpose Automatic Transmission Fluid E6AZ-19582-B (ESR-M2C163-A2) or equivalent.

DISASSEMBLY AND ASSEMBLY (Continued)

1. Install the bearing on the pinion end of the shaft using a 1-1/16 inch socket and an arbor press.

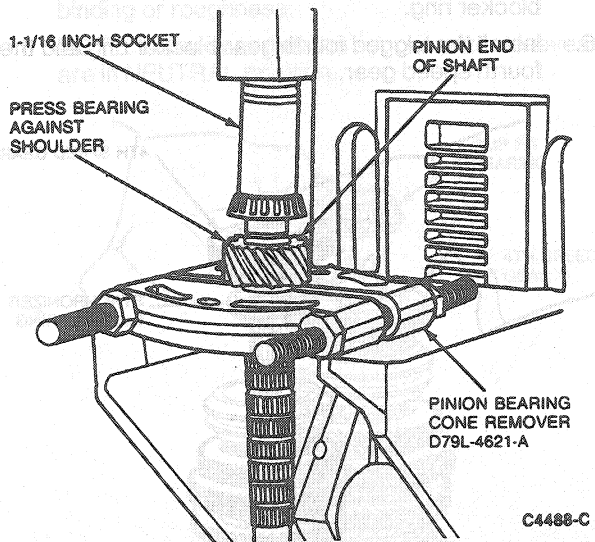

NOTE: When installing the synchronizer, align the three grooves in the first gear blocker ring with the synchronizer inserts. This allows the synchronizer assembly to seat properly in the blocker ring.

2. Slide the first speed gear and tagged blocker ring onto the main shaft. Slide the first/second synchronizer assembly into place, making sure the shift fork groove on the reverse sliding gear faces the first speed gear.

NOTE: When installing the synchronizer, align the three grooves in the second gear blocker ring with the synchronizer inserts. This allows the synchronizer assembly to seat properly in the blocker ring.

Install the synchronizer retaining ring.

1ST/2ND GEAR SYNCHRONIZER ASSY

MAKE SURE GROOVE FACES 1ST SPEED GEAR

BLOCKER RING

CONE UP

1ST SPEED GEAR

C4486-C

3. Install the tagged second speed blocker ring and the second speed gear.

