

# SECTION 07-02 Transaxle, Automatic—Cooling

SUBJECT	PAGE	SUBJECT	PAGE
<b>DIAGNOSIS AND TESTING</b>		<b>SPECIAL SERVICE TOOLS</b> .....	<b>07-02-3</b>
Oil Cooler Steel Lines.....	07-02-1	<b>SPECIFICATIONS</b> .....	<b>07-02-3</b>
Service Procedures .....	07-02-1	<b>VEHICLE APPLICATION</b> .....	<b>07-02-1</b>

## VEHICLE APPLICATION

Taurus / Sable.

## DIAGNOSIS AND TESTING

### Oil Cooler Steel Lines

When fluid leakage is found at the oil cooler (in radiator), the cooler must be replaced. Refer to Section 03-03 for oil cooler replacement procedures.

**NOTE:** The cooler lines that are attached to the transaxle are a push connect design. A special removal tool is required for non-SHO vehicles only. No tool is required for SHO vehicles with automatic transmissions. The cooler lines attached to the radiator use the conventional nut and flare fittings.

When oil cooler steel lines need replacing, each replacement line must be fabricated from the same size steel line as the original (5 / 16 inch OD for all Taurus / Sable except SHO automatic; 3 / 8 inch for Taurus SHO automatic). Using the oil line as a guide, bend the new line as required. Add the necessary fittings and install the line. After the fittings have been tightened to specification, add fluid as necessary and check for leaks.

## Service Procedures

### Taurus Automatic

#### Oil Cooler Steel Lines Using Push Connect Fittings

##### Tools Required:

- Cooler Line Disconnect Tool T86P-77265-AH

**NOTE:** For description on how to use Cooler Line Disconnect Tool T86P-77265-AH refer to Cooler Line Disconnect Tool Usage.

1. If leakage is noted at the cooler line fitting on the transaxle, remove the cooler line fitting retaining clip. Using Cooler Line Disconnect Tool T86P-77265-AH remove the cooler line.

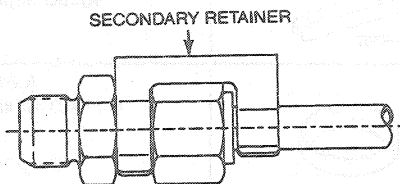
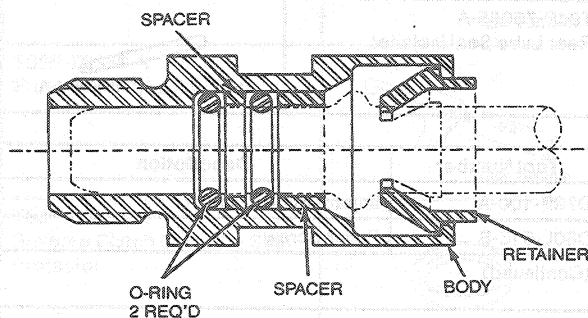

D7303-A

2. Install angled flare fitting in the transaxle. Tighten fitting to 24-31 N·m (18-22 lb-ft).
3. Cut approximately 76-102mm (3-4 inches) from the existing cooler line.

## DIAGNOSIS AND TESTING (Continued)

4. Using new cooler line steel tubing (equivalent of SAEJ526 welded low carbon lead / tin coated 5 / 16-inch OD), cut a piece of sufficient length and shape it to connect the existing line to the new flare fitting.
5. Clean all cut ends of both lines with the blade edge of the cutting tool to avoid line restrictions. Clean metal particles from the tube ends.
6. Install flare nut 87944-S8 or equivalent on the transaxle end of the new cooler line section.
7. Connect the new cooler line section to the existing cooler line using a piece of 5 / 16-inch fuel line hose and two worm drive hose clamps. Use a sufficient length of fuel line hose to achieve a 38-51mm (1-1 / 2 to 2 inches) overlap of the ends of the cooler lines.
8. Connect the cooler line to the flare fittings and tighten to 16-24 N·m (12-17 lb-ft).

### Cooler Line Disconnect Tool Usage Push Connect Fittings

**NOTE:** On some applications, it may not be possible to insert the removal tool into the fitting due to vehicle component interference. If this condition exists, the fitting must be removed from the case without disconnecting the cooler line. Turning the fitting without removing the cooler line may damage the internal O-ring of the fitting causing a leak. If the fitting is removed without disconnecting the cooler line first, a replacement angle flared type fitting must be installed. Refer to Oil Cooler Steel Lines service procedures.

For transaxle cooler line service, Cooler Line Disconnect Tool T86P-77265-AH is required. The illustration shows the tool end and its proper position for disassembly of tube from fitting. The purpose of the tool is to spread the duck-bill retainer to disengage the tube bead. The following steps are necessary for use of the tool.

To aid in the use of the tool, remove tube retaining clip, and then clean the road dirt from the fitting before inserting the tool into the fitting. Also, it is important to avoid any contamination of the fitting and transaxle. Dirt in the fitting could cause an O-ring leak.

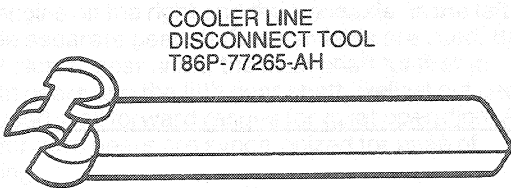

COOLER LINE  
DISCONNECT TOOL  
T86P-77265-AH

D6418-B

1. Slide tool over tube.
2. Align opening of tool with one of two tabs on the fitting duck-bill retainer.

### Cooler Line Disconnect Tool

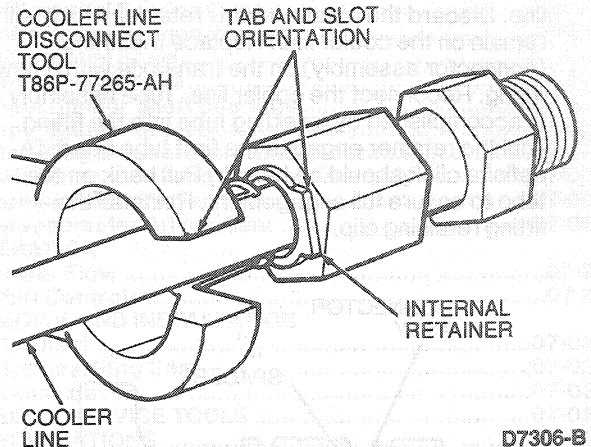

3. Firmly insert tool into fitting until it seats against tube bead. (A definite click should be heard.)

**CAUTION:** Do not attempt to separate cooler line from fitting by prying with another tool. This will break the plastic insert in fitting and bend the cooler lines at junction to fitting.

4. With thumb held against tool, firmly pull back on tube until it disengages from fitting.

Before assembly of the lines in the fitting, visually inspect the plastic retainer in the fitting for a broken tab. If a tab is broken, the fitting must be replaced. Also visually inspect the cooler lines to ensure they are not bent at the junction of the fitting.

Tube assembly is accomplished by inserting the tube into the fitting until the retainer engages the tube bead. (A definite click should be heard.) Pull back on the tube to ensure full engagement. Install tube retaining clip.

### Taurus SHO Automatic

**CAUTION:** Do not attempt to separate Taurus SHO cooler lines from fitting by prying with a tool.

**DIAGNOSIS AND TESTING (Continued)**

1. If leakage is noted with the cooler line fitting on the transaxle, remove the cooler line fitting retaining clip. Then, manually squeeze / depress the plastic insert / retainer in the push connect fitting and disconnect the cooler line. No disconnect tool is required to remove the cooler line. Discard the plastic insert / retainer which will remain on the cooler line. Replace the fitting (connector assembly) on the transaxle with a new fitting. Reconnect the cooler line. Tube assembly is accomplished by inserting tube into the fitting until the retainer engages the first tube bead. (A definite click should be heard.) Pull back on the tube to ensure full engagement. Reinstall the fitting retaining clip.

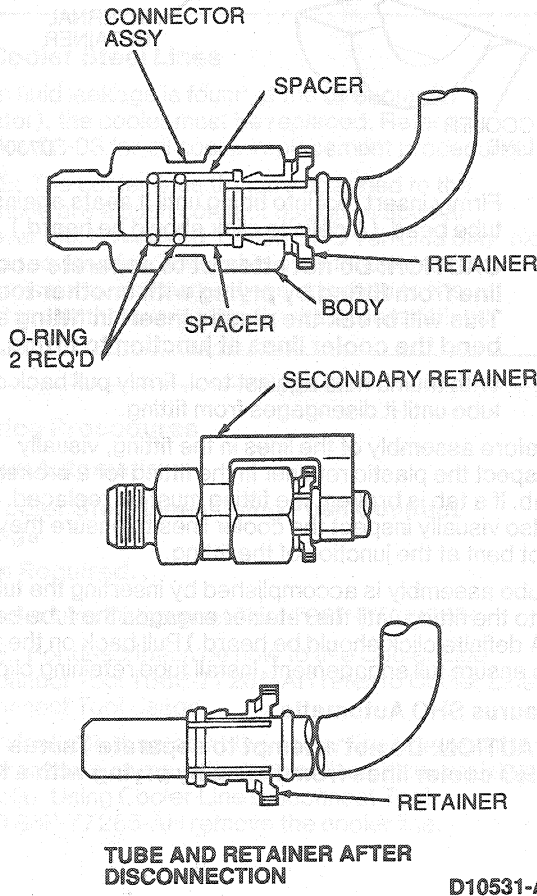

2. Install angled flare fitting in the transaxle. Tighten fitting to 24-31 N-m (18-22 lb-ft).
3. Cut approximately 76-102mm (3-4 inches) from the existing cooler line.
4. Using new cooler line steel tubing (equivalent of SAEJ526 welded low carbon lead / tin coated 3/8-inch OD), cut a piece of sufficient length and shape it to connect the existing line to the new flare fitting.
5. Clean all cut ends of both lines with the blade edge of the cutting tool to avoid the line restrictions. Clean metal particles from the tube ends.
6. Install flare nut 87944-S8 on the transaxle end of the new cooler line section.
7. Connect the new cooler line section to the existing cooler line section using a piece of 3/8-inch fuel line hose and two worm drive hose clamps. Use a sufficient length of fuel line hose to achieve a 38-51mm (1-1/2 to 2 inch) overlap of the ends of the cooler lines.
8. Connect the cooler line to the flare fitting and tighten to 16-24 N-m (12-17 lb-ft).

**SPECIFICATIONS**

**TORQUE SPECIFICATIONS**

Description	N-m	Lb-Ft
Angled Flare Fittings	24-31	18-22
Flare Fittings	16-24	12-17

**SPECIAL SERVICE TOOLS**

Tool Number / Description	Illustration
T86P-77265-AH Cooler Line Disconnect Tool	 T86P-77265-AH