

REMOVAL AND INSTALLATION (Continued)

3. Install the inner nylon washer or speed control adapter, if so equipped, the master cylinder push rod, and the black stoplamp switch bushing on the brake pedal pin. Do not oil stoplamp switch. Position the stoplamp switch so that it straddles the push rod with the slot on the pedal pin and the switch outer frame hole just clearing the pin. Slide the switch down onto the pin and push rod. Slide assembly inboard toward brake pedal arm. Install outer nylon washer and push rod retainer. Lock retainer securely.

4. Tighten booster retaining nuts to 21-29 N-m (16-21 lb-ft).
 5. Connect stoplamp switch wire to the switch.
 6. Connect battery ground cable.

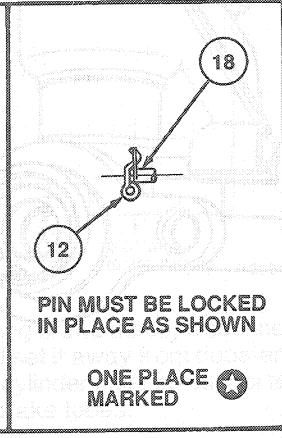
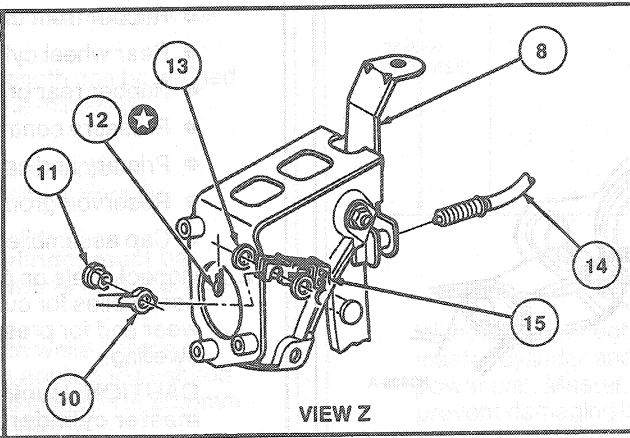
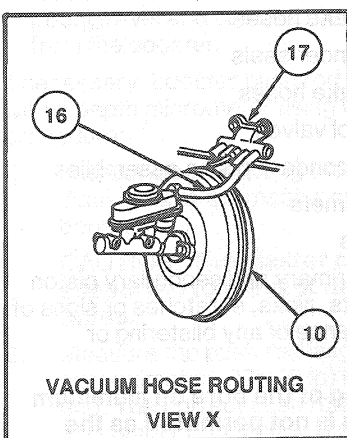
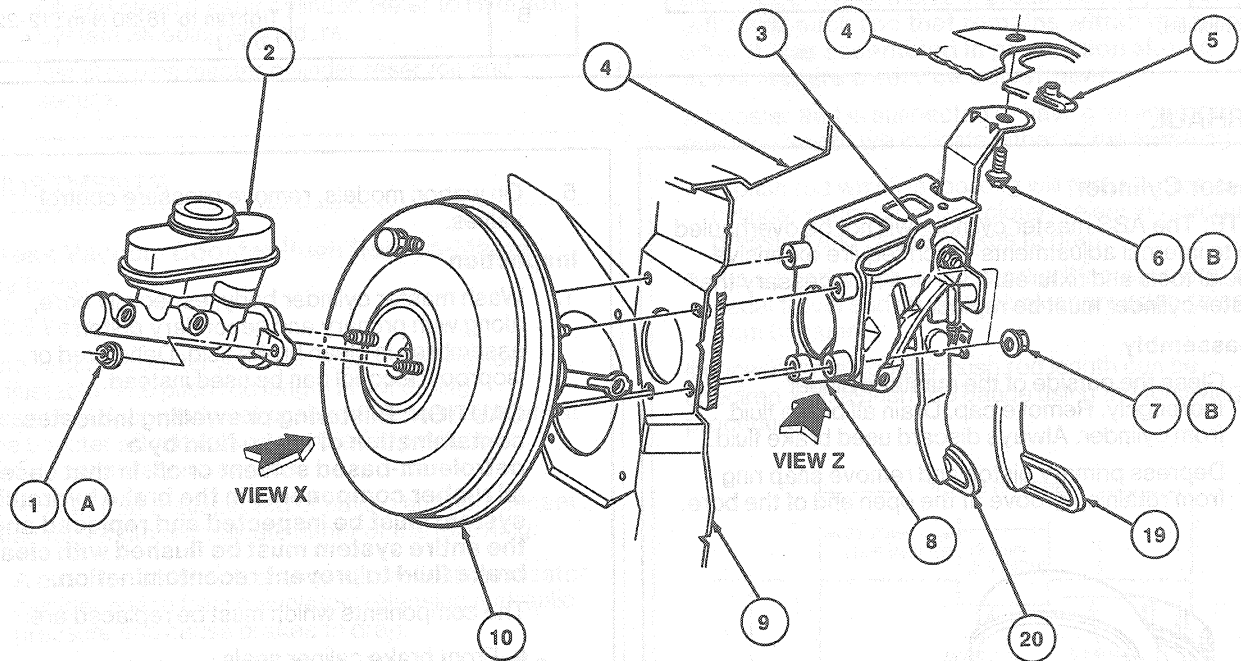

H3981-H

Item	Part Number	Description
1A	382802-S191	Nut
2	2A032 (Sedan) 2C156 (Wagon)	Master Cylinder Assy

(Continued)

Item	Part Number	Description
3	7B633	Clutch Control Assy
4	—	Cowl
5	N800538-S100	U-Nut

(Continued)