

REMOVAL AND INSTALLATION (Continued)

(Continued)

ROUTE ANTI-LOCK WIRE  
UNDER PARKING BRAKE  
CABLE-BOTH SIDES

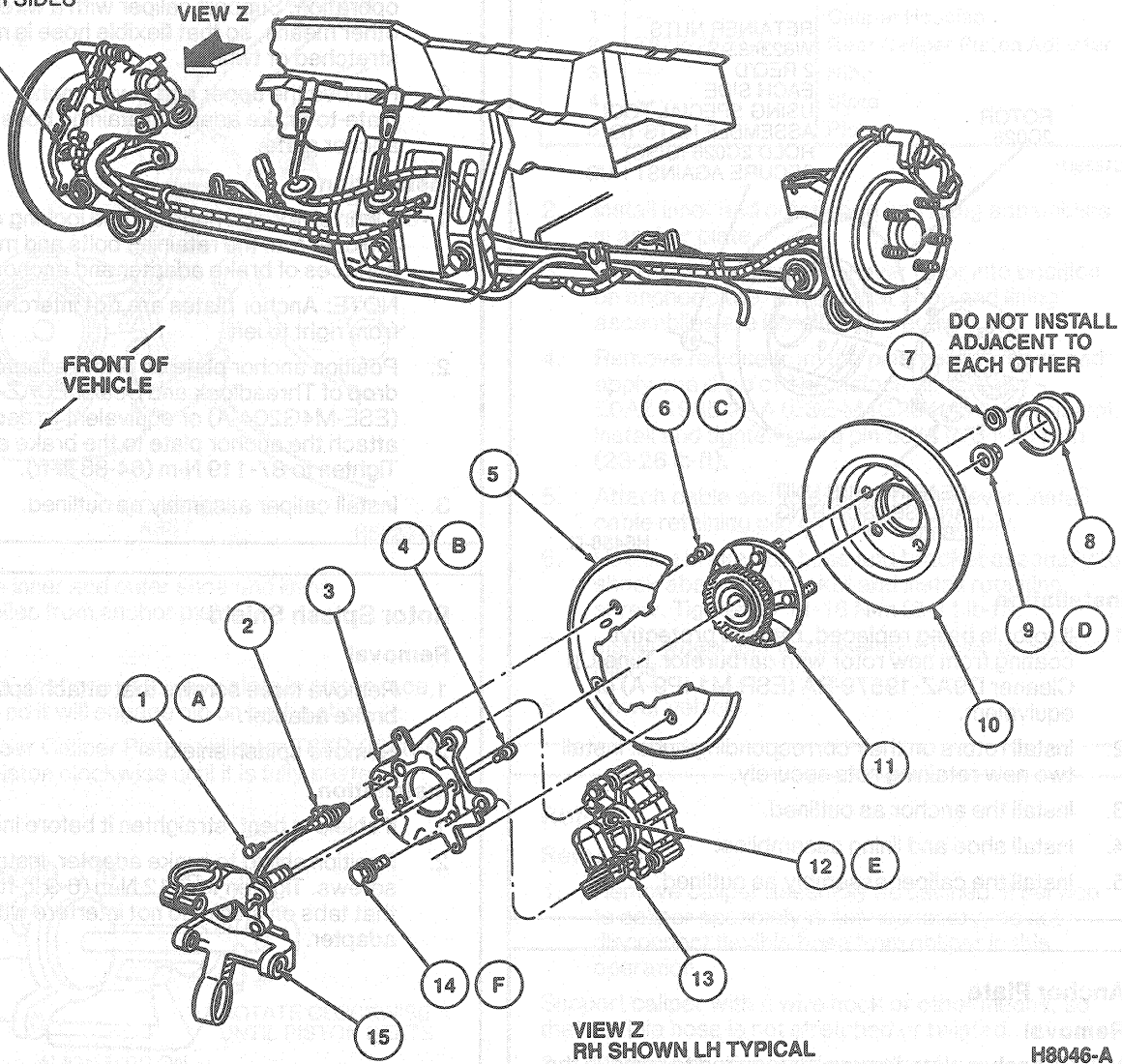

VIEW Z  
RH SHOWN LH TYPICAL

H8046-A

Item	Part Number	Description
1A	N605518-S100	Bolt
2	2C216 (LH) 2C190 (RH)	Anti-Lock Sensor Assy
3	2C101 (LH) 2C100 (RH)	Disc Brake Adapter
4B	N805086-S100	Bolt (4 Req'd)
5	2C028	Splash Shield
6C	N602726-S2	Bolt (3 Req'd)
7	W623485-S2	Retainer Nut (2 Req'd)
8	1N135	Dust Cap
9D	2B423	Nut
10	2C026	Rotor
11	2B664	Hub Assy
12E	—	Bleed Screw

(Continued)

Item	Part Number	Description
13	2K327 (RH) 2K328 (LH)	Caliper Assy
14F	N805163-S150	Bolt (2 Req'd)
15		Knuckle Assy
A		Tighten to 4.5-6.8 N-m (3-5 Lb-Ft)
B		Tighten to 59-81 N-m (44-60 Lb-Ft)
C		Tighten to 8-12 N-m (6-9 Lb-Ft)
D		Tighten to 255-345 N-m (188-254 Lb-Ft)
E		Tighten to 8-13 N-m (6-10 Lb-Ft)

(Continued)