

DESCRIPTION (Continued)

Item	Part Number	Description
E		Tighten to 8-13 N·m (6-10 Lb·Ft)

(Continued)

Item	Part Number	Description
F		Tighten to 87-119 N·m (64-88 Lb·Ft)

TH8046A

Station Wagon

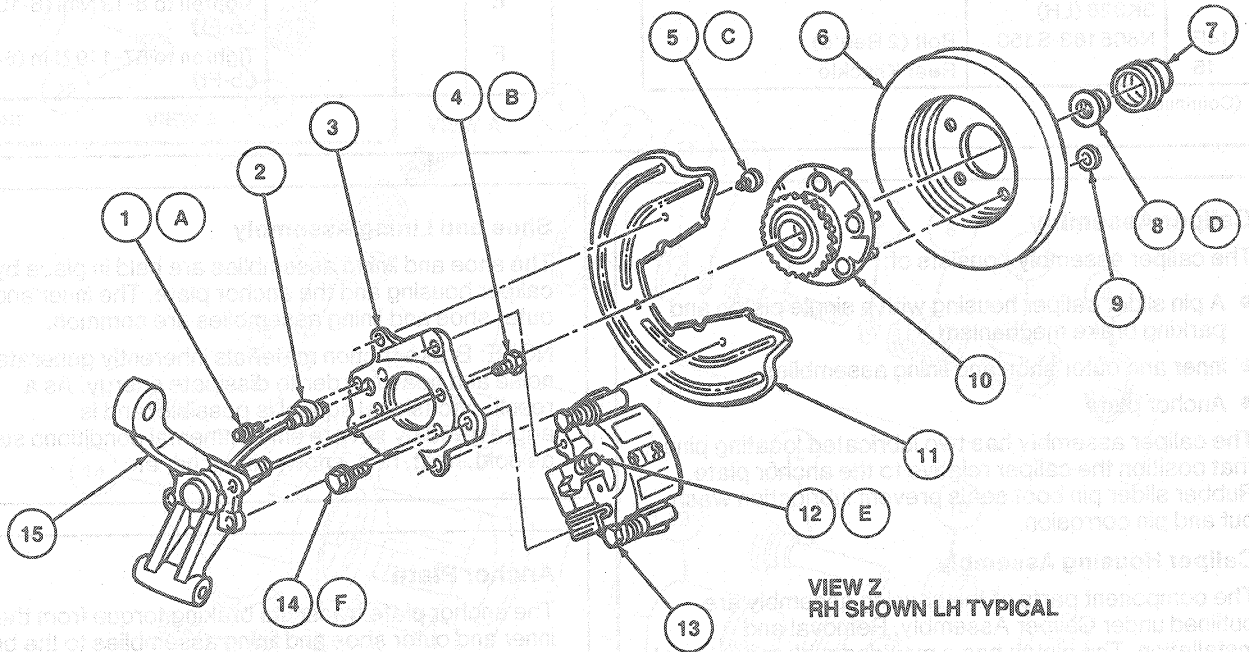

ROUTE ANTI-LOCK WIRE OVER PARKING BRAKE CABLE

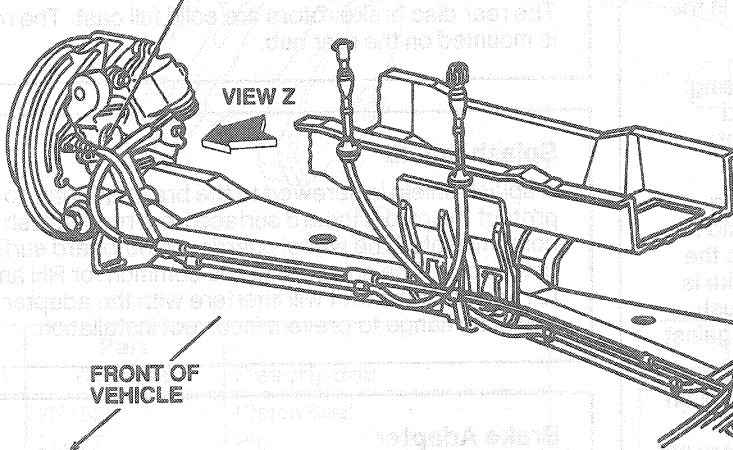

FRONT OF VEHICLE

ROUTE ANTI-LOCK WIRE OVER PARKING BRAKE CABLE

H8047-A

Item	Part Number	Description
1A	N605518-S100	Bolt
2	2C216 (LH) 2C190 (RH)	Anti-Lock Sensor Assy

(Continued)

Item	Part Number	Description
3	2C100 (RH) 2C101 (LH)	Disc Brake Adapter
4B	N805086-S100	Bolt (4 Req'd)
5C	N602726-S2	Bolt (3 Req'd)

(Continued)